

# 2021 TECHNICAL REGULATIONS

Revision Date: **April 23, 2021**



Series:

**IMSA PROTOTYPE CHALLENGE**

**P3-2**

Class:

**LE MANS PROTOTYPE 3-2**



Sanctioned by:

**INTERNATIONAL  
MOTOR SPORTS  
ASSOCIATION**

One Daytona Blvd.  
Daytona Beach, FL 32114  
(O) +1 (386) 310-6500  
(F) +1 (386) 310-6695  
[www.imsa.com](http://www.imsa.com)

## Table of Contents

<b>Foreword:</b>	<b>3</b>		
<b>ARTICLE 1. DEFINITIONS SPECIFIC TO THE TECHNICAL REGULATIONS</b>	<b>6</b>		
<b>ARTICLE 2. TECHNICAL PHILOSOPHY</b>	<b>7</b>		
2.1. Technical Eligibility	7		
2.2. Balance of Performance Adjustment	7		
2.3. Changes	7		
<b>ARTICLE 3. USING THESE TECHNICAL REGULATIONS</b>	<b>7</b>		
3.1. Structure	7		
3.2. Conflict Resolution	7		
3.3. Final Authority	8		
<b>ARTICLE 4. HOMOLOGATION</b>	<b>8</b>		
4.1. Homologation Regulations	8		
4.2. Homologation Process	8		
4.3. Homologation Files and Documentation	8		
4.4. Homologation Inspection	9		
4.5. Homologation Testing	9		
4.6. Homologation Identifier	9		
4.7. Conditions for Use of a Specific Homologation	9		
<b>ARTICLE 5. TECHNICAL ELIGIBILITY</b>	<b>10</b>		
5.1. Technical Credential Process	10		
5.2. Technical Credential Files and Documentation	10		
5.3. Technical Eligibility Testing	10		
5.4. Technical Credential Identifier	11		
5.5. Conditions for Use of Specific Technical Credential	11		
<b>ARTICLE 6. BALANCE OF PERFORMANCE</b>	<b>11</b>		
6.1. Balance of Performance	11		
<b>ARTICLE 7. SAFETY</b>	<b>11</b>		
7.1. Driver Safety Harness System	11		
7.2. Seat	11		
7.3. Driver Containment Nets	12		
7.4. Protective Padding	12		
7.5. Protective Shielding	12		
7.6. Master Electrical Switches	12		
7.7. Fire Suppression System	13		
<b>ARTICLE 8. DEFINITION OF CLASS</b>	<b>14</b>		
8.1. LMP3	14		
<b>ARTICLE 9. VEHICLE SYSTEMS</b>	<b>14</b>		
9.1. General	14		
9.2. Modifications to the Specification	14		
9.3. Servicing, Repair, and Replacement	14		
9.4. Dimensions	14		
9.5. Chassis	15		
9.6. Driver Interface	15		
9.7. Bodywork	16		
9.8. Aerodynamic Elements	16		
9.9. Engine System	16		
9.10. Boost Management	17		
9.11. Drive System	17		
9.12. Cooling System	17		
9.13. Fuel System	18		
9.14. Brake System	18		
9.15. Steering System	18		
9.16. Suspension System	19		
9.17. Wheels & Tires	19		
9.18. Electronics	20		
<b>ARTICLE 10. SERIES REQUIRED ELECTRONICS</b>	<b>20</b>		
10.1. Series Scrutineering Data System	20		
10.2. Safety Light System	20		
10.3. X2 Transponder System	21		
10.4. Leader Light System	22		
10.5. Back-lit Panel	22		
10.6. Pro-Am Light	22		
10.7. In-Car Camera	22		
<b>ARTICLE 11. REFUELING SYSTEM</b>	<b>22</b>		
11.1. Fuel Transfer	22		
11.2. Pit Tank	23		
11.3. Peripheral Connections	23		
11.4. Refueling Hose	24		
11.5. Tank Support Stand	25		
11.6. Boom	25		
11.7. Refueling Restrictor	25		
11.8. Level Sensor System	26		

## Foreword:

For all Members, the IMSA RULES of the International Motor Sports Association establish the foundation for the organization and conduct of all IMSA Sanctioned Events. The IMSA RULES take effect immediately upon publication.

The purpose of the RULES is to: (i) promote safety, the sport of automobile Competition and IMSA, (ii) enhance Competition, (iii) ensure the quality, fairness and integrity of the IMSA programs and operations and (iv) achieve prompt finality in the Competition results (“**Purpose**”).

### **ALL MEMBERS ARE REQUIRED TO REVIEW THESE IMSA RULES CAREFULLY.**

The **IMSA RULES** consist of following three (3) sections and the Event Supplementary Regulations (**SR**):

- The Technical Regulations, which outline the rules and regulations for the specific cars and equipment. The Technical Regulations may be modified or changed at any time by the publication of a Technical Bulletin, amending the Technical Regulations.
- The IMSA Sporting Regulations (**ISR**), which concern Competitor and Event procedures, as well as guidelines for the safe and uniform operation of the sport. The ISR may be modified or changed at any time by the publication of a Competition Bulletin, amending the ISR.
- The Series Supplementary Regulations (**SSR**) that provides Series-specific information about each IMSA Series. The SSR is integrated into the ISR and are designated with “(SSR)” next to the Paragraph title. The SSR may be modified or changed at any time by the publication of a Competition Bulletin, amending the SSR.

Any portion of the RULES may be modified through Bulletins (Competition Bulletins and Technical Bulletins, respectively) and takes force when published. Once published, the Bulletin shall take precedence over the applicable portion of the RULES. Additionally, the RULES may be modified for an Event by the Race Director through the mandatory briefing instructions.

## **HOW TO READ THE RULES**

IMSA Technical Regulations follow a common philosophy across all Classes. The IMSA Technical Regulation philosophy can be summed in the following concepts:

- Cars are constructed and regulated to a controlled standard, the vehicle Homologation.
- Modifications to the Car are not permitted unless specifically stated in the applicable class's Technical Regulations.
- The Car, at all times, must adhere to:
  - The current Homologation Document(s) and valid extension documents (e.g., EVO).
  - The Manufacturer's or Constructor's Parts Manual.
  - Manufacturer submitted and IMSA approved declarations (where applicable).
  - The IMSA Technical Regulations for the Class
- Normal adjustment of the Car is permitted as defined by the applicable Car's Homologation and Class's Technical Regulations.
- Repair of the Car, parts, and components is permitted, provided it serves no additional purpose other than the repair itself. All such repairs must meet all Constructor / Manufacturer specifications and regulatory requirements.

(cont.)

Modifications by an Entrant to parts, systems, and/or components of the Car is not permitted for any reason. An Entrant wishing to perform any modification(s) must present modification(s) to the applicable Manufacturer or Constructor for formal approval from the applicable Homologating Authority for the Class. Entrants are not permitted to work directly with a Homologating Authority(s).

Entrants must have a current copy of the applicable Homologation for their Car Model at all times, as well as full access to the Manufacturer's / Constructor's Part Manual. Both of these documents together clearly identify the compliant specification of the Car and will be used as reference materials for both the Entrant and IMSA. A copy of the Homologation may be provided by the applicable Manufacturer / Constructor or purchased from the Homologating Authority.

IMSA's regulations work in conjunction with Homologation regulations from a Homologating Authority. This sometimes creates conflicts across the various regulation sets. Often the Homologating Authority has a combined set of Technical and Homologation regulations.

The hierarchy of these various regulations applies in descending order is as follows:

1. IMSA Class Technical Regulations and Bulletins
2. These IMSA Technical Regulations shall govern in any case where a conflict exists with the Homologation Regulations and Documentation.
3. Homologation Authority Technical Regulations and corresponding Homologation Form & Parts Book

#### **Example 1: Incorrect process**

A Team has found that a suspension part of the Car is prone to failure when going over large bumps. The Team chooses to resolve the problem on their own and modifies the part with components made in their own shop, which are not in the Homologation or Parts Manual of the Car. IMSA Technical Staff find this modification during a post-Race inspection. IMSA finds that the car is not in the approved configuration and the Entrant is penalized.

#### **Example 2: Correct process**

A Team suspects a part on the Car may be prone to failure during longer races. The Team therefore informs their Manufacturer or Constructor representative of their concern. The Manufacturer or Constructor agrees that a modification or redesign is appropriate and submits a written proposal with supporting documentation to the Homologating Authority for review. Upon approval the Homologation documents are updated and distributed for equitable customer awareness and part implementation.

Homologation Authority for the Class:

<b>Class</b>	<b>Homologating Authority</b>
P3-2	ACO

### EXECUTIVE LEADERSHIP MASTHEAD

<b>John Bishop* / Bill France, Sr.*</b>	<b>Founders – IMSA</b>
<b>Dr. Don Panoz*</b>	<b>Legacy Vice Chairman</b>
<b>Jim France</b>	<b>Chairman</b>
<b>Lesa Kennedy</b>	<b>Director</b>
<b>Ed Bennett</b>	<b>Chief Executive Officer</b>
<b>John Doonan</b>	<b>President</b>
<b>Tracey Lesetar-Smith</b>	<b>Director and Legal Counsel</b>
<b>David Pettit</b>	<b>Senior Vice President, Marketing</b>
<b>Simon Hodgson</b>	<b>Vice President, Competition</b>
<b>Brandon Huddleston</b>	<b>Vice President, Partnership Marketing and Business Development</b>

\*Deceased

## ARTICLE 1. DEFINITIONS SPECIFIC TO THE TECHNICAL REGULATIONS

- 1.1.1. **Car** means a singular representation of a Car Model possessing a Technical Credential, entered by an Entrant in an Event.
- 1.1.2. **Car Model** means a specific model of a vehicle constructed by an IMSA-recognized Manufacturer Partner, and intended for Competition.
- 1.1.3. **Class** means a category for Cars sharing a common set of Homologation Regulations and differentiated from others by type of Car Model.
- 1.1.4. **Competition** means a contest of competitive nature in which a Car takes part during an Event and results of which Competition are published.
- 1.1.5. **Constructor** means an entity that designs and builds race car chassis.
- 1.1.6. **Entrant** means an entity or person who has entered a Car that has been accepted for Competition and holds an IMSA Membership in the capacity of an Entrant or Entrant/Driver.
- 1.1.7. **Event** means an IMSA Sanctioned motorsport activity. It includes the designated Race as well as all periods for registration, inspections, practice Sessions, qualifying Sessions, racing, pre- and post-Race activities and inspections, and rain or postponed dates related thereto.
- 1.1.8. **Homologate** means to execute the Homologation Process.
- 1.1.9. **Homologated** means a Car Model approved through the Homologation Process.
- 1.1.10. **Homologation** means the concept of all things associated with Homologation Authority approval via the Homologation Process.
- 1.1.11. **Homologation Authority** means an entity with the authority to Homologate.
- 1.1.12. **Homologation Documentation** means all files, documents, information, and communication associated with the issuance of official approval of Homologation.
- 1.1.13. **Homologation Identifier** means the unique identifier (generally including a string of characters identifying the Category or Class of Homologation followed by a sequential number assigned to the Car Model) serving as a reference to the official approval of Homologation, assigned by the Homologation Authority.
- 1.1.14. **Homologation Process** means all procedures associated with petitioning a Homologation Authority for approval that a Car Model complies with the Homologation Regulations.
- 1.1.15. **Homologation Regulations** means a set of technical requirements and criteria used to design, construct, and document a Car Model intended for racing in a specific category or class of racing.
- 1.1.16. **Manufacturer** means a Manufacturer Partner constructing an approved Car Model.
- 1.1.17. **Manufacturer Partner** means a recognized IMSA Official Automotive Partner.
- 1.1.18. **Specification** means all technical characteristics of the Car Model defined by the Homologation and Technical Credential.
- 1.1.19. **Specific Homologation** means the Homologation specific to a particular Car Model.
- 1.1.20. **Specific Technical Credential** means the Technical Credential specific to a particular Car Model.
- 1.1.21. **Technical Credential** means the concept of all things associated with IMSA approval via the Technical Credential Process.
- 1.1.22. **Technical Credential Documentation** means all files, documents, information, and communication associated with the Technical Credential Process.
- 1.1.23. **Technical Credential Identifier** means the unique identifier that serves as a reference to the Technical Credential granted by the IMSA. Example: IMSA GTLM 20170101 [GTE-0XX].
- 1.1.24. **Technical Credential Process** means all procedures associated with petitioning IMSA for approval that a Car Model is Technically Eligible.
- 1.1.25. **Technical Eligibility Form** means the form which documents the Specific Technical Credential.

1.1.26. **Technically Eligible** means conforms to all technical requirements and criteria defined by these Technical Regulations.

## ARTICLE 2. TECHNICAL PHILOSOPHY

### 2.1. Technical Eligibility

- 2.1.1. Car Models Technically Eligible for participation in IMSA Events are issued a Technical Credential Identifier.
- 2.1.2. Cars representing a Car Model must always respect the Specification.
- 2.1.3. To be issued a Technical Credential Identifier for participation in this Class, a Car Model must:
  - a. Be a Car Model constructed by an IMSA-recognized Manufacturer Partner.
  - b. Hold a valid Homologation conforming to the Homologation Regulations and Homologation Documentation specific to the Class, approved and issued by an IMSA-recognized Homologation Authority.
  - c. Successfully complete the IMSA Technical Credential Process.
- 2.1.4. IMSA is the sole authority to define the Technical Eligibility of a Car Model and issue the Technical Credential.

### 2.2. Balance of Performance Adjustment

- 2.2.1. N/A

### 2.3. Changes

- 2.3.1. Changes to the Specification are prohibited, unless explicitly authorized by IMSA.
- 2.3.2. Manufacturers alone must petition IMSA to change the Specification; requests by Entrants are not recognized.

## ARTICLE 3. USING THESE TECHNICAL REGULATIONS

### 3.1. Structure

- 3.1.1. These Technical Regulations are structured to assist Manufacturers and Entrants in accurate interpretation of the technical expectations and enforcement of the IMSA Technical Philosophy.
  - a. A brief description of each Article and its purpose follows:

Article / Name	Description / Purpose
1. Definitions Specific to the Technical Regulations	Standardized meanings for specific terms of these Technical Regulations.
2. Technical Philosophy	Guiding principles for these Technical Regulations.
3. Using These Technical Regulations	General structure, purpose, and clarifying statements for these Technical Regulations.
4. Homologation	Pertinent topics related to Homologation.
5. Technical Eligibility	Pertinent topics related to Technical Eligibility.
6. Balance of Performance	General processes associated with competitive equivalency.
7. Safety	Regulatory requirements associated with mandatory safety systems.
8. Definition of Class	Statement of specific Class, Homologation, and Technical Eligibility requirements.
9. Series Required Electronics	Regulatory requirements associated with mandatory electronic systems.
10. Vehicle Systems	Approved modifications to the Homologation component of the Car Model Specification.
11. Refueling System	Regulatory requirements associated with specified refueling system.

### 3.2. Conflict Resolution

- 3.2.1. These IMSA Technical Regulations shall govern where a conflict exists with the Homologation Regulations and Documentation.

### 3.3. Final Authority

- 3.3.1. IMSA is the Final Authority with respect to these Technical Regulations.

## ARTICLE 4. HOMOLOGATION

---

### 4.1. Homologation Regulations

- 4.1.1. Reference to the official Homologation Regulations defining the requirements applicable to these Technical Regulations is provided in ARTICLE 8. DEFINITION OF CLASS.

### 4.2. Homologation Process

- 4.2.1. The procedures of the Homologation Process are used to verify that the Car Model meets the necessary requirements and criteria defined by the official set of Homologation Regulations.
- 4.2.2. This process generally includes the following components or phases, which must be completed to the satisfaction of the Homologation Authority:
- Homologation Files and Documentation
  - Homologation Inspection
  - Homologation Testing
  - Final Approval
  - Identification Assignment
- 4.2.3. Homologation Process fees may apply.

### 4.3. Homologation Files and Documentation

- 4.3.1. All files and documents required by the Homologation Authority to support the Homologation Process; including but not limited to:
- Basic Homologation Form
  - Homologation Extension Form(s)
  - Data Sheet(s)
  - CAD Models and Drawings
  - Logged Vehicle Data
  - Homologation Testing Data
- 4.3.2. Basic Homologation Form: Documents how the Car Model complies with the Homologation Regulations; including photographs, drawings, descriptions, and measurements defining the characteristics, components, parameters, and/or dimensions and tolerances for:
- General Vehicle
  - Specific Vehicle Systems
  - System Assemblies, Parts and Components
  - Modifications to the Original Series Production Car (if applicable)
- 4.3.3. Homologation Extension Forms: Describe all approved modifications made to the Basic Homologation Form, including but not limited to modifications for:
- Correction of incorrect information
  - Safety reasons
  - Reliability reasons
  - Evolutions of type introduced on the original Car Model (if applicable)
  - Evolutions for new components and/or characteristics that cancel and replace those featured in the original Basic Homologation Form
  - Variant options, such as endurance packages



- 4.3.4. CAD Models and Drawings: As required by the Homologation Authority to support the Homologation Process; including but not limited to:
  - a. Complete Vehicle CAD Models
  - b. Specific Component CAD Models
  - c. Specific Component Drawings
  - d. Engine Air Intake Restrictor(s)
- 4.3.5. Homologation Testing Data: Information, documentation, data, and results from Homologation Testing.

#### **4.4. Homologation Inspection**

- 4.4.1. The inspection process for drawings, CAD models, any reference component, and the constructed Car Model by the Homologation Authority.
  - a. These inspections confirm that a Car Model complies with the Homologation Regulations and are generally conducted as part of the following phases of the Homologation Process:
    - i. Design
    - ii. Construction
    - iii. Final Approval

#### **4.5. Homologation Testing**

- 4.5.1. Any testing conducted by the Homologation Authority to support the Homologation Process; including, but not limited to:
  - a. Straight-line Testing
  - b. Wind Tunnel Testing
  - c. Engine Dyno Testing
  - d. Track Testing

#### **4.6. Homologation Identifier**

- 4.6.1. The Homologation Identifier is electronically stamped/associated with all information, documentation and files associated with the Homologation.

#### **4.7. Conditions for Use of a Specific Homologation**

- 4.7.1. At all times during IMSA-sanctioned Events it is the Entrant's responsibility to ensure the configuration of the Car Model represents the Homologation components of the Specification; including:
  - a. As-Homologated Configuration
  - b. As-Delivered Configuration
  - c. Parts Manual
  - d. Homologation Extension Form Configuration
- 4.7.2. The original, As-Homologated Configuration of the Car Model must not be modified unless permitted by these Technical Regulations.
- 4.7.3. The As-Delivered Configuration of a Car must respect the as-received configuration from the Car Model Manufacturer, unless permitted by these Technical Regulations.
- 4.7.4. The Parts Manual is the official parts catalogue for the Car Model as defined by the Car Model Manufacturer or Constructor:
  - a. Specific parts listed in the Parts Manual must be used on all representations of a Car Model unless permitted by these Technical Regulations.
- 4.7.5. To be eligible for use in any IMSA-sanctioned Event, modifications detailed in Homologation Extension Forms must:
  - a. Comply with these Technical Regulations.
  - b. Be approved by, or have initiated the process to obtain approval from, the Homologation Authority, and appended to the Car Model Homologation.
  - c. Be approved by IMSA.
  - d. Be available to all Entrants of the relevant Homologated Car for the next Event.

## ARTICLE 5. TECHNICAL ELIGIBILITY

### 5.1. Technical Credential Process

- 5.1.1. Manufacturers may begin the Technical Credential Process for a Car Model provided the Car Model:
  - a. Holds, or have initiated the process to obtain approval from, a valid Homologation as defined in these Technical Regulations.
  - b. Is approved by IMSA.
- 5.1.2. The procedures of the Technical Credential Process are used to verify that the Car Model meets the necessary requirements and criteria defined by these Technical Regulations.
- 5.1.3. This process generally includes the following components or phases, which must be completed to the satisfaction of IMSA:
  - a. Technical Credential Files and Documentation
  - b. Technical Eligibility Testing
  - c. Final Approval
  - d. Identification Assignment
- 5.1.4. IMSA may request Manufacturers submit reference components to support the Technical Credential process.
  - a. IMSA may retain these components without compensation.
- 5.1.5. IMSA may request Manufacturers submit reference tooling and/or templates to support the Technical Inspection process.
- 5.1.6. Technical Credential fees may apply.

### 5.2. Technical Credential Files and Documentation

- 5.2.1. All files and documents required by IMSA to support the Technical Credential Process; including but not limited to:
  - a. Technical Eligibility Form
  - b. Data Sheet(s)
  - c. CAD Models and Drawings
  - d. Logged Vehicle Data
  - e. Electronic Controller Calibrations
  - f. Technical Eligibility Testing Data
- 5.2.2. Technical Eligibility Form: Documents how the Car Model complies these Technical Regulations; including:
  - a. List of all files and documentation associated with the Specific Homologation of the Car Model
  - b. List of all files and documentation associated with the Specific Technical Credential of the Car Model
  - c. All approved IMSA-Only Declarations
- 5.2.3. CAD Models and Drawings: As required by IMSA to support the Technical Credential Process; including but not limited to:
  - a. Complete Vehicle CAD Models
  - b. Specific Component CAD Models
  - c. Specific Component Drawings
  - d. Additional components requested by IMSA
- 5.2.4. Technical Eligibility Testing Data: Information, documentation, data, and results from Technical Eligibility Testing.

### 5.3. Technical Eligibility Testing

- 5.3.1. Any testing conducted by IMSA to support the Technical Credential Process; including, but not limited to:
  - a. Restrictor Flow
  - b. Engine Dyno
  - c. Wind Tunnel
  - d. On-track Testing
  - e. Refueling Testing

#### 5.4. Technical Credential Identifier

- 5.4.1. The Technical Credential Identifier is electronically stamped/associated with all information, documentation and files associated with the Technical Credential.

#### 5.5. Conditions for Use of Specific Technical Credential

- 5.5.1. At all times during IMSA-sanctioned Events it is the Entrant's responsibility to ensure the configuration of the Car Model represents the approved Technical Credential components of the Specification.

### ARTICLE 6. BALANCE OF PERFORMANCE

---

#### 6.1. Balance of Performance

- 6.1.1. Not Applicable

### ARTICLE 7. SAFETY

---

#### 7.1. Driver Safety Harness System

- 7.1.1. Cars must be equipped with a minimum 6-point Driver safety harness with a valid label demonstrating compliance with one of the following standards:
- FIA Standard 8853/98: FIA Safety Harnesses Standard
    - [FIA Technical List #24](#): Harnesses Homologated by the FIA according to the FIA Standards 8853/98 and 8854/98
  - FIA Standard 8853-2016: Safety Harnesses
    - [FIA Technical List #57](#): Harnesses Homologated according to the FIA Standard 8853-2016
  - SFI Specification 16.5: Stock Car Driver Restraint Assemblies
    - [Specification](#)
    - [Manufacturers](#)
  - SFI Specification 16.6: Advanced Motorsport Driver Restraint Assemblies
    - [Specification](#)
    - [Manufacturers](#)
- 7.1.2. Installation must be performed in accordance with instructions provided by the system supplier and/or manufacturer.
- Belt components must be installed at each anchor point to prevent accidental release or opening.
  - Individual belt straps must be independent; any method or attempt to combine individual straps is prohibited.
  - Elastic retention straps are prohibited on shoulder belts.
- 7.1.3. Harnesses must be replaced at the request of IMSA, or whenever the following conditions occur:
- Expiration:
    - FIA Homologated: Immediately following December 31<sup>st</sup> of the year printed on the label.
    - SFI Certified: Immediately following December 31<sup>st</sup> two (2) years after the year of Manufacture.
  - Damage:
    - Following a severe collision.
    - Webbing is cut or frayed or weakened due to actions of chemicals or sunlight.
    - Buckles are bent, deformed, rusted, or improperly functioning.
- 7.1.4. Entrants are responsible for ensuring the Driver safety harnesses and all associated components are properly labeled, installed, used, and maintained.

#### 7.2. Seat

- 7.2.1. As Homologated.

### 7.3. Driver Containment Nets

- 7.3.1. Not Applicable

### 7.4. Protective Padding

- 7.4.1. Cars must be equipped with non-flammable protective padding with a valid label demonstrating compliance with one of the following standards:
- FIA Standard 8857-2001: FIA Roll Cage Padding Standard
    - [FIA Technical List #23](#): Roll Cage Padding Homologated by the FIA
  - SFI Specification 45.1: Roll Cage Padding
    - [Specification](#)
    - [Manufacturers](#)
- 7.4.2. Installation requirements:
- Padding must be located to protect the Driver (body and/or helmet) against direct contact with the safety cage in a collision.
  - Protective padding must be securely affixed to prevent rolling or displacement.

### 7.5. Protective Shielding

- 7.5.1. Cars must be equipped with shielding to protect the Driver against contact with cockpit equipment in a collision.
- 7.5.2. Installation requirements:
- Installations must not impact cockpit exit.
  - Installations of protective shielding must use fire resistant materials and if impact padding is used it must comply with FIA 8857-2001, SFI 45.1 or SFI 45.2.
  - Installations must be presented to and approved by IMSA at the time of Technical Inspection.

### 7.6. Master Electrical Switches

- 7.6.1. Cars must be equipped with interior and exterior master electrical switches.
- 7.6.2. Master electrical switches must be spark-proof, and when activated must:
- De-energize all electrical circuits.
  - Stop the engine.
- 7.6.3. The interior master switch must be installed within the cockpit and located so the driver may activate the switch when seated in a normal position with safety belts fastened and steering wheel in place.
- 7.6.4. The exterior master switch must be installed proximal to the fire suppression control at (or near) the base of the left side A-Pillar.
- Exterior master switch must be located such that emergency responders may activate with a single action:
    - Using a gloved finger, or tools such as a hook.
    - Unencumbered by bodywork, windscreen wipers, or any equipment that may require multiple actions.
  - A method for preventing activation of the exterior master switch:
    - May be enabled when the Car is in Technical Inspection, in the Paddock, or located near large crowds, such as during pre-Race activities.
    - Must be removed prior to participation in on-track activity.
- 7.6.5. Interior and exterior master switches must be clearly identified by a self-reflective symbol of a red spark surrounded by a white-edged, blue triangle with a base greater than 30 mm.

## 7.7. Fire Suppression System

- 7.7.1. Cars must be equipped with a fire extinguisher system with a valid label demonstrating compliance with one of the following standards:
  - a. FIA Standard for plumbed-in Fire Extinguisher Systems in Competition Cars (1999):
    - i. [FIA Technical List #16](#): Extinguisher Systems Homologated by the FIA
  - b. FIA Standard 8865-2015: Plumbed-in and Hand-Held Fire Extinguisher Systems
    - i. [FIA Technical List #52](#): Plumbed-in Fire Extinguisher Systems according to FIA Standard 8865-2015
- 7.7.2. Extinguishing media must be compatible with all aspects and accessories of the fire suppression system.
  - a. Compliance with FIA 8865-2016 is recommended.
  - b. All system components must be used and serviced per manufacturer specifications.
- 7.7.3. System must be securely mounted.
  - a. The following must be visible without the use of photography, tools, or seat removal:
    - i. Pressure gauge (if present)
    - ii. Date of manufacture
    - iii. Next required service date
  - b. Nozzles must not point directly at the Driver's face.
- 7.7.4. System must include an exterior activation mechanism proximal to the exterior master electrical switch at (or near) the base of the left side A-Pillar.
  - a. Exterior activation mechanism must be located such that emergency responders can activate with a single action:
    - i. Using a gloved finger, or tools such as a hook.
    - ii. Unencumbered by bodywork, windscreen wipers, or any equipment that requires multiple actions.
  - b. A method for preventing activation of the exterior activation mechanism:
    - i. Must be enabled when the Car is in Technical Inspection, in the Paddock, or located near large crowds, such as during pre-Race activities.
    - ii. Must be removed prior to participation in on-track activity.
- 7.7.5. Identification
  - a. Exterior activation mechanism must be marked with a self-reflective symbol with a red edge surrounding a red "E" inside a white circle at least 100 mm in diameter.
- 7.7.6. Inspection
  - a. IMSA may require removal of the fire bottle for Technical Inspection.
  - b. Entrant is responsible to demonstrate proper system function of the interior and exterior fire suppression activation mechanisms, using the "test" mode if present.

## ARTICLE 8. DEFINITION OF CLASS

### 8.1. LMP3

- 8.1.1. Class Structure: 2015-2019 LMP3 cars compete in the LMP3 Class of the IMSA PROTOTYPE CHALLENGE (IPC).
- 8.1.2. Eligibility Requirements: To be eligible for participation in the Class, a Car Model must respect the Specification defined by the Homologation and Technical Eligibility requirements:
  - a. Homologation (LMP3):

<b>Homologation Authority:</b>	Automobile Club de l'Ouest (ACO)
<b>Homologation Specification:</b>	Automobile Club de l'Ouest (ACO) LMP3
<b>Homologation Regulations:</b>	2017 Technical Regulations for LMP3 Prototypes
<b>Additional Documentation:</b>	

## ARTICLE 9. VEHICLE SYSTEMS

### 9.1. General

- 9.1.1. All Vehicle Systems and associated sub-systems are listed in this Article.
  - a. Where change to the Homologated Vehicle Systems is permitted, regulatory text is **bold and underlined**.
  - b. Where change to the Homologated Vehicle Systems is prohibited, regulatory text is *light grey*.
  - c. Advisory statements are in normal text.

### 9.2. Modifications to the Specification

- 9.2.1. Entrants are permitted to execute the following changes to parameters defined by the Homologation component of the Car Model Specification, provided these Technical Regulations, all current Technical Bulletins, and the Technical Credential are fully respected:
  - a. Adjust component settings defined as adjustable.
  - b. Replace components with parts defined as optional.
- 9.2.2. Manufacturers must make any declarations listed in these Technical Regulations in the Technical Eligibility Form.
- 9.2.3. Further authorization to modify the Specification and/or As-Delivered Condition is granted via the following formal communication methods:
  - a. Published IMSA Technical Bulletin
  - b. Approved updates to the IMSA Technical Eligibility Form
- 9.2.4. Informal and/or verbal communication is not considered valid authorization.

### 9.3. Servicing, Repair, and Replacement

- 9.3.1. All servicing or repair must be made in good faith to restore the Car and all components to their originally intended form and function as defined by the Specification.
- 9.3.2. Entrants are permitted to replace damaged or worn components provided these Technical Regulations are respected.

### 9.4. Dimensions

- 9.4.1. General
  - a. IMSA's calibrated measurement instruments are the official measurement instruments.
- 9.4.2. Reference Surface
  - a. The lowest plane of the underside of the car of the Car is measured to the Technical Inspection scale plane.

#### 9.4.3. Mass

- a. The minimum mass for all Car Models is 930 kg.
- b. Car mass is measured as-raced minus Driver and Fuel using the IMSA scales during Technical Inspection.

#### 9.4.4. Ballast

**a. Entrants are permitted to add or remove ballast to achieve minimum mass:**

- i. Ballast must be in plate or panel form.
- ii. Addition or removal of ballast during the race is prohibited.

**b. Entrants using Cars without specific Homologated locations must:**

- i. Locate all ballast inside the cockpit in the passenger's location.
- ii. Secure all ballast per FIA Article 253-16 in both dimensions and characteristics of fixation methods.
- iii. Design fixations such that tools are required for its removal.

#### 9.4.5. Ground Clearance

#### 9.4.6. Overall Dimensions

- a. Length
- b. Width
- c. Height
- d. Wheelbase
- e. Track
- f. Overhang
- g. Width

### 9.5. Chassis

#### 9.5.1. General

**a. Entrants are permitted to execute minimum modifications for the installation of components.**

- i. All modifications must be approved by IMSA.

#### 9.5.2. Air Jack System

### 9.6. Driver Interface

#### 9.6.1. General

#### 9.6.2. Steering Wheel

#### 9.6.3. Pedal Box

**a. Entrants are permitted to apply non-slip adhesives to the surface of driver pedals.**

#### 9.6.4. Shifting Mechanism

#### 9.6.5. Driver Adjustable Components

#### 9.6.6. Driver Cooling Systems

**a. Entrants are permitted to install a maximum of two (2) Driver Cooling Systems, i.e. Cool Suits.**

- i. Driver cooling systems must use non-flammable refrigerant (e.g. R134a, water).
- b. Installations must meet the following conditions:
  - i. The mounting location and installation for the primary system is unrestricted provided it serves no purpose other than retaining the cooling system in the event of a collision.
  - ii. Any secondary driver cooling system must be mounted on the top of the ballast box.
  - iii. All driver cooling system components must be securely mounted.
  - iv. The use of hook and loop fasteners (Velcro) is prohibited.

**c. Entrants may install Driver Ventilation Ducts**

- i. A NACA duct is permitted to be installed in the side window for the purpose of cooling the driver
- ii. Maximum of one (1) per side with two (2) ducts permitted per car
- iii. Maximum cutout area of 26 cm x 16 cm
- iv. No duct shall break the outward plane of the structure on which it is installed
- v. Ducts must be translucent
- vi. Duct and/or hoses must not impede cockpit exit or driver's visibility

**9.7. Bodywork**

## 9.7.1. General

**a. The following films are permitted to be added to the front windscreen:**

- i. Tear-off
- ii. Anti-fog

## 9.7.2. Bodywork Seams

**a. Entrants are permitted to apply tape or vinyl around refueling receptacle seams and/or rear wing end fence adjustment holes.**

## 9.7.3. Decals

**a. Entrants are permitted to apply removable die cut sponsorship decals with the approval of IMSA.****9.8. Aerodynamic Elements**

## 9.8.1. General

## 9.8.2. Splitter

## 9.8.3. Dive Planes

## 9.8.4. Body Gurney

## 9.8.5. Wings

## 9.8.6. Rear Wing Gurney

- a. Ligier LMP3 cars are required to utilize the reduced 10 mm wing gurney for Event(s) at the Daytona International Speedway.

## 9.8.7. Floor

## 9.8.8. Friction Blocks

## 9.8.9. Diffuser

**9.9. Engine System**

## 9.9.1. General

- a. Manufacturer seals must be respected

## 9.9.2. Engine

## 9.9.3. Oiling System

- a. Approved lubricants are permitted to be utilized.

## 9.9.4. Lambda

## 9.9.5. Engine RPM

## 9.9.6. Intake

## 9.9.7. Exhaust

## 9.9.8. Turbo



9.9.9. Engine Control Unit (ECU)

9.9.10. Engine Transportation Crate

## 9.10. Boost Management

9.10.1. Maximum Boost Pressure

9.10.2. Boost Pressure Ratio

9.10.3. Boost Control Strategy Inputs

9.10.4. Calculation Method

## 9.11. Drive System

9.11.1. General

- a. Manufacturer seals must be respected

9.11.2. Fluids & Lubricants

- a. **Unrestricted.**

9.11.3. Clutch

9.11.4. Gearbox

9.11.5. Gears

- a. A gear set consists of the following ratios, and must always be used in its entirety:
  - i. 6 forward ratios
  - ii. 1 reverse ratio
  - iii. 1 final drive ratio
  - iv. 1 drop gear (if applicable)
- b. The standard mandatory Gear Ratio Set for LMP3 is the "Short" Gear Set.
- c. For Daytona the "Long" Gear Set is mandatory.

9.11.6. Gearbox Control Unit

9.11.7. Differential

9.11.8. Axles

9.11.9. Uprights

## 9.12. Cooling System

9.12.1. General

9.12.2. Fluids

- a. **Entrants are permitted to utilize the following approved cooling fluids:**
  - i. Water
  - ii. Air
  - iii. Non-glycol based fluids

9.12.3. Inlet Blockers

9.12.4. Water System

9.12.5. Oil Cooling System

### 9.13. Fuel System

#### 9.13.1. General

- a. Maximum Capacity
  - i. The maximum fuel system capacity for all cars is 85 liters.
  - ii. The maximum fuel capacity is the total volume of fuel contained in the Car.

#### 9.13.2. Fuel Types

- a. The approved fuel for the Class is IMSA E10, as supplied by VP Fuels.
  - i. IMSA may require a fuel sample for inspection via a gas chromatograph.

#### 9.13.3. Fuel Cell

- a. **Entrants must use blocks or balls to achieve maximum fuel system capacity**
  - i. Any device, system, or procedure to increase, even temporarily, the total fuel storage capacity beyond the maximum is prohibited.

#### 9.13.4. Fuel Lines

#### 9.13.5. Fuel Sample Port

- a. **Entrants must equip the Car with the approved self-sealing connector for extraction of fuel samples:**
  - i. Approved Connector: Staubli P/N: CBI06.7251/IA/JKV.
  - ii. Must be located immediately before the injector nozzles.
  - iii. Installation must be approved by IMSA.

#### 9.13.6. Refueling Receptacle

### 9.14. Brake System

#### 9.14.1. General

#### 9.14.2. Fluids & Lubricants

- a. **Unrestricted.**

#### 9.14.3. Bias Assembly

#### 9.14.4. Master Cylinders

#### 9.14.5. Brake Lines

#### 9.14.6. Calipers

#### 9.14.7. Rotors

#### 9.14.8. Pads

- a. **Friction material is unrestricted.**
- b. Backing Plates must be ferrous.

#### 9.14.9. Ducting

#### 9.14.10. Brake Duct Inlet Blockers

- a. **Entrants are permitted to apply opaque adhesive tape to block off portions of the brake duct inlet openings.**

#### 9.14.11. Anti-Lock Braking System

### 9.15. Steering System

#### 9.15.1. General

#### 9.15.2. Fluids & Lubricants

- a. **Unrestricted.**

## 9.16. Suspension System

### 9.16.1. General

### 9.16.2. Geometry Elements

### 9.16.3. Springs

#### a. Entrants are permitted to change primary spring rates:

- i. The As-delivered number of springs per wheel must be respected.

### 9.16.4. Dampers

- a. Dampers must be utilized with valving and internals as per the applicable Constructor's IMSA Technical Credential.
- b. Dampers must be used with intact seals.
- c. Dampers must be unmodified from the approved rebuilding and sealing vendor. The approved rebuilding and sealing vendor is:

Chassis Constructor	Damper	Address
Ligier, Norma	Ohlins	Ohlins North America Attn: LMP3 Service 703 Grove Street Hendersonville, NC 28792
Ave Riley	JRI	TBD

- d. Entrant is responsible for all costs associated with the sealing program, including seals, inspections, labor, shipping, and handling.
  - i. Entrant is responsible for shipping to the approved rebuilding vendor with adequate time for the vendor to perform the required service.
- e. Dampers must be identified with car number when in use and when being sealed.

### 9.16.5. Bump Rubbers and Packers

#### a. Unrestricted.

### 9.16.6. Anti-Roll Bar

### 9.16.7. Third Elements

## 9.17. Wheels & Tires

### 9.17.1. General

### 9.17.2. Wheels

### 9.17.3. Wheel Attachment

### 9.17.4. Tires

- a. The approved tire supplier for this Class is Michelin.
- b. Tires must be used in accordance with SSR Attachment 3.

## 9.18. Electronics

### 9.18.1. General

### 9.18.2. Data Logger

- a. IMSA reserves the right to download and/or view all logged data at any time.
- b. Entrants may install additional electronics equipment as follows:
  - i. Stand-alone cameras (Go-Pro type)
  - ii. "Connected" cameras (VBox type)
  - iii. Pit lane timers
- c. If any such equipment uses a GPS antenna it must be mounted no less than 75 cm away from the mandatory GPS antenna.
- d. Any such equipment must be correctly mounted and in place for pre-event scrutineering.
- e. Any electronic device liable to interfere with the proper function of the on-board electronics (included but not limited to ECU, Data logger, ADR, GPS antenna) is forbidden.
- f. IMSA may at any time ask for removal of any electronic equipment if it is deemed to pose a safety problem or if it interferes with the mandatory electronic equipment.

### 9.18.3. Telemetry

### 9.18.4. Wiring Loom

### 9.18.5. Sensors

### 9.18.6. Radio

- a. **Entrants are permitted to install a single two-way voice radio with car-to-pit communication capability in compliance with the corresponding Series Sporting Regulations.**

### 9.18.7. Rear View Camera

- a. **Where not homologated, Entrants may install a rear-view camera system.**

### 9.18.8. Auxiliary Power Sources

## ARTICLE 10. SERIES REQUIRED ELECTRONICS

### 10.1. Series Scrutineering Data System

- 10.1.1. Cars must be equipped with an IMSA-supplied data logger when requested.
  - a. Cars must have a dedicated 12 V power lead to install the IMSA-supplied data logger.
  - b. Power lead shall remain on as long as the master kill is switch is on.

### 10.2. Safety Light System

- 10.2.1. Cars must be equipped with the MSE Yellow Light Kit to indicate active flag status.
  - a. The Kit contains the following components:
    - i. Yellow Indicator Light
    - ii. Mounting Bracket
    - iii. Antenna
    - iv. Wiring Loom and Instructions

- 10.2.2. The Safety Light system must be installed and functioning during on-track activity.
- a. The Yellow Indicator Light must be prominently installed within the cockpit, in clear line of sight of the driver.
  - b. Antenna Installation: The supplied antenna must be mounted:
    - i. On the Car roof
    - ii. Away from other antennae
    - iii. Following the diagram below (a ground plane is not required):

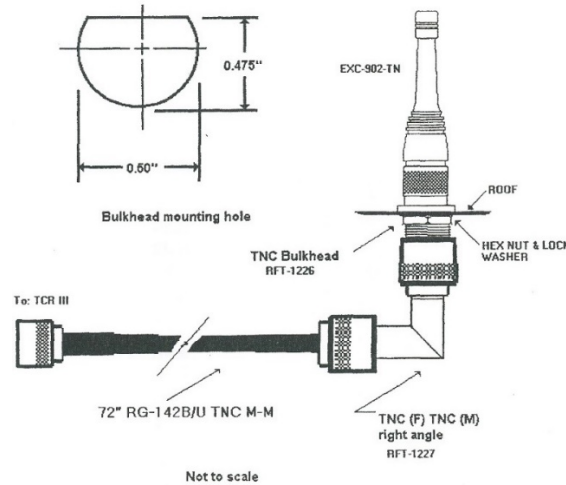

- c. Wiring Loom Installation: The Wiring Loom has a flying lead input for +12 VDC and Ground to interface with additional wiring referenced in the installation instructions.
  - i. Entrants must supply additional wiring as required.

10.2.3. An activating receiver is available from IMSA during Safety Checks at each Event and remains the property of IMSA.

- a. Entrants must surrender the receiver when required by IMSA.
- b. A lost or damaged receiver is subject to a replacement fee referenced in the IMSA Accessories form.

10.2.4. Cars must be equipped with MoTec Driver ID Module #RG OTC

- a. Available for purchase through MoTec.

10.2.5. Entrant must supply Driver ID Plugs.

10.2.6. Female Driver ID plug(s), (i.e. Driver #1 through Driver #5) may be installed inside the Car cockpit or attached to the individual Drivers' helmets.

- a. Alternative installations must be approved by IMSA.

10.2.7. Transponder and plugs must be tested and operate to the satisfaction of the Timing and Scoring Officials.

### 10.3. X2 Transponder System

10.3.1. Installation of the X2 Transponder System must be in accordance with the Manufacturer submitted form added to the Technical Credential.

- 10.3.2. Cars must be equipped with the X2 Transponder System Kit.
  - a. Kit contains the following components:
    - i. X2 Transponder
    - ii. Isolation Mounts
    - iii. MoTec Driver ID Module #RG OTC
  - b. Entrant must supply the following additional item(s):
    - i. X2 Transponder Mounting Bracket (available for purchase as listed in the IMSA Accessories Order Form).
    - ii. M4 Socket Head Cap Screw and washer
    - iii. Driver ID Plugs
- 10.3.3. Female Driver ID plug(s), (i.e. Driver #1 through Driver #5) may be installed in the car cockpit or attached to the individual Driver's helmets.
  - a. Alternative installations must be approved by IMSA.
- 10.3.4. Entrant is responsible for replacing lost or damaged X2 Transponder.
  - a. Replacement cost is listed in the IMSA Accessories Order Form.
- 10.3.5. Transponder and plugs must be tested and operate to the satisfaction of Timing and Scoring Officials.
- 10.3.6. Transponder consumes less than 300 mA (10-15 VDC), and must:
  - i. Be a fused, 12-volt DC configuration
  - ii. Meet the specifications defined by ISO 7637

#### 10.4. Leader Light System

#### 10.5. Back-lit Panel

#### 10.6. Pro-Am Light

#### 10.7. In-Car Camera

- 10.7.1. See SSR 15 and SSR 16.

## ARTICLE 11. REFUELING SYSTEM

---

### 11.1. Fuel Transfer

- 11.1.1. Fuel must be transferred from the autonomous supply tank to the Car using the equipment and methods defined in this Article.
  - a. Approved equipment as defined herein must be:
    - i. Unmodified.
    - ii. Installed and operational.
  - b. Approved method:
    - i. Gravity.
- 11.1.2. Fuel transferred to the autonomous supply tank must be delivered by means of a hose fitted with a self-sealing connector (e.g. dry break, cam-lock) connected to the autonomous supply tank.

## 11.2. Pit Tank

11.2.1. Construction of the Autonomous Supply Tank must:

- a. Comply with FIA Appendix J Drawing n° 252-7 with the exception of the top plate shape and dimensions.
- b. Have a simple cylindrical internal shape.
- c. Not have any additional internal parts that could improve flow.
- d. Have a tolerance on bottom flatness of less than 3 mm inside the tank.
- e. Have the flow restrictor top face at the level of the internal surface of the bottom of the supply tank.
- f. Not have sensors other than as required by IMSA.

11.2.2. Refueling tank height is measured from the top surface of the vessel, not including vent, cover plate or fasteners at a distance 1.25 meters from the outermost face of the pit wall.

- a. The required refueling tank height is 2.0 meters with a tolerance of +0/-1.0 cm.
- b. Once inspected by an IMSA Official the autonomous tank may not be moved until the conclusion of the Race or upon an approved retirement via TIMS.

## 11.3. Peripheral Connections

11.3.1. Tanks must be equipped with the IMSA-specified peripheral connections between the tank outlet and the refueling hose.

- a. Parts must be purchased from RPXpress and used unmodified:

Part Number	Part	Description
BSR-FR FN40	Restrictor Housing	Bottom Tank 12-bolt housing
ATL-TF 147	12-Bolt Gasket	
BSR.FR.R.35GOLD	35 mm Restrictor	Upper Restrictor (for positive seal to elbow)
BSR-FR 1981	Bottom 80 deg. Elbow	Female Camlock x 2" Male
<del>BSR-P5K56</del>	<del>Adapter</del>	<del>Adapter 2" Male to 1 1/2" Camlock</del>
BSR.PK56.SS	Restrictor Housing	Deadman Outlet, 2" Male to 1 1/2" Camlock
BSR.P.5K.RPX.SS	Hose Coupler	1.5" OD barb to Deadman outlet
1 Deadman Valve:		
BSR-FR-R003	Deadman Valve (new design)	Stainless Deadman Valve
BSR-FR-R002	Deadman Valve (old design)	Brass Deadman Valve
BSR-FR-R290	Mandatory Restrictor (LMP3)	29.0 mm restrictor

b. Refueling System Assembly Illustration

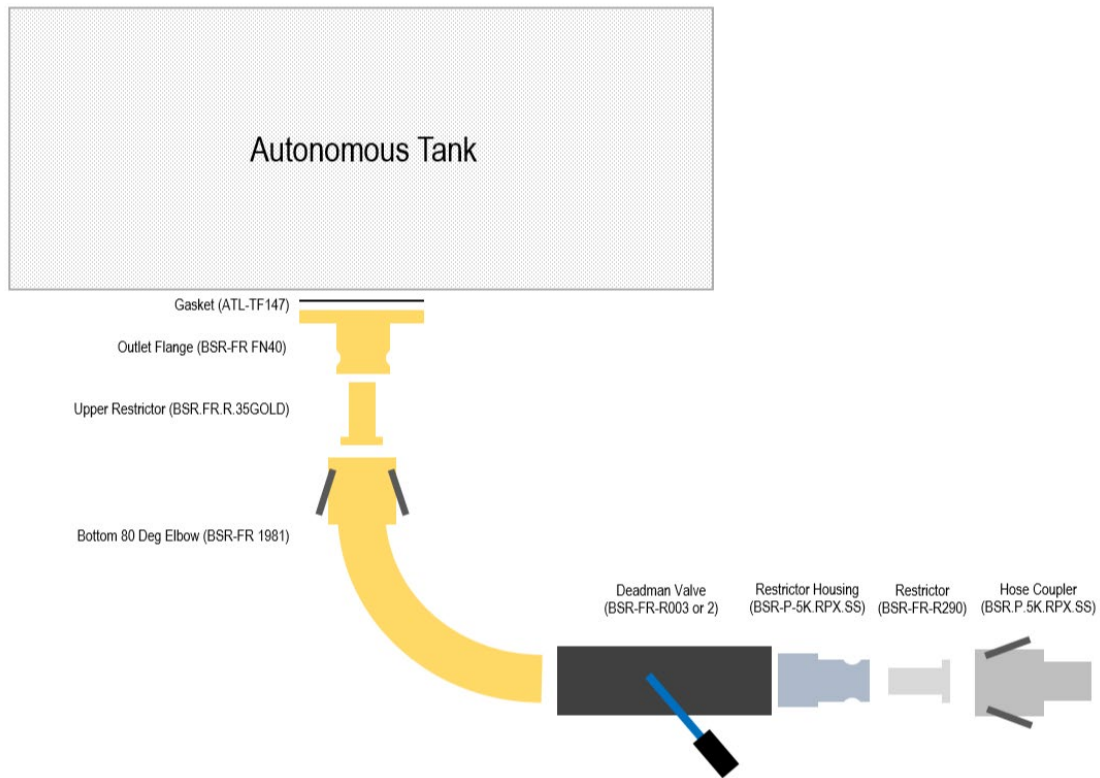

- 11.3.2. Deadman valve and bottom 80 deg. elbow assembly must be securely braced to remain attached to the tank in the event of an incident.
  - a. Mechanisms preventing normal operation of the deadman valve are prohibited.
- 11.3.3. During refueling the air vent outlet must be connected using an appropriate coupling to the tank.
- 11.3.4. A sight glass is permitted to be installed to the outside of the supply tank, and must be equipped with isolating valves mounted as close as possible to the tank.

**11.4. Refueling Hose**

- 11.4.1. Refueling/vent hoses must have one end equipped with a self-sealing connector to fit the autonomous supply tank outlet.
- 11.4.2. Refueling/vent hoses are permitted to be protected for the sole purpose of resisting abrasion damage.
  - a. Cover must be easily removable by means of full-length Velcro ® or zipper.
  - b. Cover must be non-reflective.
- 11.4.3. Hose maximum inside diameter:
  - a. Dual-Port systems must be less than 1.5 inches for all hoses.
  - b. Single-Port (coaxial) systems must be less than 1.5 inches for Refueling Hose and less than 75.0 mm for the vent hose.



11.4.4. Refueling hose minimum length must be greater than 4 meters.

- a. Minimum length is measured from the most distant plane of the dry break/fuel probe to the most distant plane of the fuel hose coupler.

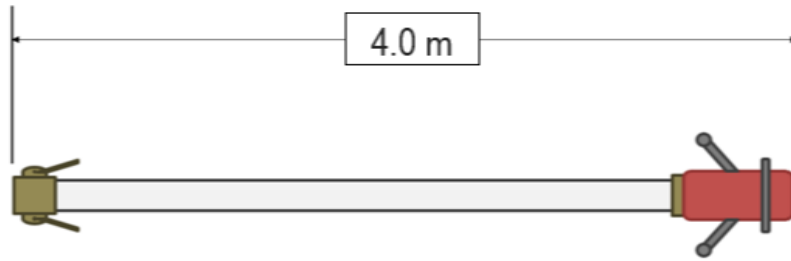

## 11.5. Tank Support Stand

11.5.1. The tank must be attached to one of the following:

- a. Through a tower, to a trolley meeting the following requirements:
  - i. All tower components must be assembled without any degree of freedom in relation to the trolley.
  - ii. Have a surface area greater than two (2) square meters.
  - iii. Utilize four (4) self-braking casters.
  - iv. Be ballasted with weight exceeding that of the tank when filled with fuel.
- b. Scissor style (X-brace) stand

11.5.2. Trolley is permitted to have load sensors for the sole purpose of weighing fuel in the Autonomous Tank.

## 11.6. Boom

Not Applicable

## 11.7. Refueling Restrictor

11.7.1. During refueling, all fuel entering the Car must pass through the refueling restrictor.

11.7.2. Refueling Restrictor must meet the following criteria:

- a. Material must be an aluminum alloy.
- b. Must comply with the Fuel Restrictor Part Drawing at the end of these Technical Regulations.

11.7.3. IMSA may adjust the refueling rig restrictor diameter via Technical Bulletins.

- a. Refueling Restrictors may be purchased from RPXpress (Phone: +1-828-428-0820 Email [lmcelwain@rpxpress.com](mailto:lmcelwain@rpxpress.com)).

11.7.4. Refueling Restrictors are sealed by IMSA Technical Officials.

- a. Entrants must receive written approval from IMSA to remove seals following inspection, and seals must be replaced by IMSA Technical Officials prior to on-track activity.
- b. The following bolts must be drilled for safety-wire sealing of the restrictor:
  - i. Two (2) adjacent bolts of the Restrictor Housing
  - ii. Two (2) Hinge Bolts (threaded section) of the Outlet Pipe Cam Lock
  - iii. Two (2) Lock Lever Arms of the Refueling Hose Cam Lock
  - iv. A 0.125 inch hole must be drilled in the two female camlock levers on the bottom 80 deg. elbow assembly 0.5 inches below pin in the locations indicated in yellow on the diagram below:



**11.8. Level Sensor System**

- 11.8.1. Not Applicable

