

2022 TECHNICAL REGULATIONS

Revision Date: 01/06/2022



Series:

IMSA MICHELIN PILOT CHALLENGE



Class:

TCR



Sanctioned by:

**INTERNATIONAL
MOTOR SPORTS
ASSOCIATION**

One Daytona Blvd.
Daytona Beach, FL 32114
(O) +1 (386) 310-6500
(F) +1 (386) 310-6695
www.imsa.com

Table of Contents

ARTICLE 1. DEFINITIONS SPECIFIC TO THE TECHNICAL REGULATIONS	6	7.10. Boost Management	13
ARTICLE 2. TECHNICAL PHILOSOPHY	6	7.11. Drive System	13
2.1. Technical Eligibility	6	7.12. Cooling System	13
2.2. Changes	7	7.13. Fuel System	13
2.3. Conflict Resolution	7	7.14. Brake System	14
2.4. Final Authority	7	7.15. Steering System	14
2.5. Conditions for Use of a Specific Homologation	7	7.16. Suspension System	14
ARTICLE 3. TECHNICAL TESTING AND VERIFICATION	7	7.17. Wheels & Tires	15
3.2. Technical Testing	7	7.18. Electronics	15
ARTICLE 4. BALANCE OF PERFORMANCE	8	ARTICLE 8. SERIES REQUIRED ELECTRONICS	16
4.1. Balance of Performance	8	8.1. Series Scrutineering Data System	16
ARTICLE 5. SAFETY	8	8.2. Safety Light System	17
5.1. Driver Safety Harness System	8	8.3. Driver ID System	17
5.2. Seat	8	8.4. X2 Transponder System	18
5.3. Driver Containment Nets	9	8.5. Leader Light System	18
5.4. Protective Padding	9	8.6. Back-lit Panel	18
5.5. Master Electrical Switches	9	8.7. Pro-Am Light	18
5.6. Fire Suppression System	9	8.8. In-Car Camera	18
ARTICLE 6. DEFINITION OF CLASS	10	ARTICLE 9. REFUELING SYSTEM	19
6.1. TCR	10	9.1. Fuel Transfer	19
ARTICLE 7. VEHICLE SYSTEMS	10	9.2. Pit Tank	19
7.1. General	10	9.3. Peripheral Connections	19
7.2. Modifications to the Specification	10	9.4. Refueling Hose	20
7.3. Servicing, Repair, and Replacement	10	9.5. Tank Support Stand	21
7.4. Dimensions	10	9.6. Boom	21
7.5. Chassis	11	9.7. Refueling Restrictor	21
7.6. Driver Interface	11	9.8. Autonomous Tank Sensor System	22
7.7. Bodywork	12		
7.8. Aerodynamic Elements	12		
7.9. Engine System	12		

Foreword:

For all Members, the IMSA RULES of the International Motor Sports Association establish the foundation for the organization and conduct of all IMSA Sanctioned Events. The IMSA RULES take effect immediately upon publication.

The purpose of the RULES is to: (i) promote safety, the sport of automobile Competition and IMSA, (ii) enhance Competition, (iii) ensure the quality, fairness and integrity of the IMSA programs and operations and (iv) achieve prompt finality in the Competition results (“Purpose”).

ALL MEMBERS ARE REQUIRED TO REVIEW THESE IMSA RULES CAREFULLY.

The IMSA RULES consist of following three (3) sections and the Event Supplementary Regulations (SR):

- The Technical Regulations, which outline the rules and regulations for the specific cars and equipment. The Technical Regulations may be modified or changed at any time by the publication of a Technical Bulletin, amending the Technical Regulations.
- The IMSA Sporting Regulations (ISR), which concern Competitor and Event procedures, as well as guidelines for the safe and uniform operation of the sport. The ISR may be modified or changed at any time by the publication of a Competition Bulletin, amending the ISR.
- The Series Supplementary Regulations (SSR) that provides Series-specific information about each IMSA Series. The SSR is integrated into the ISR and are designated with “(SSR)” next to the Paragraph title. The SSR may be modified or changed at any time by the publication of a Competition Bulletin, amending the SSR.

Any portion of the RULES may be modified though Bulletins (Competition Bulletins and Technical Bulletins, respectively) and takes force when published. Once published, the Bulletin shall take precedence over the applicable portion of the RULES. Additionally, the RULES may be modified for an Event by the Race Director through the mandatory briefing instructions.

HOW TO READ THE RULES

IMSA Technical Regulations follow a common philosophy across all Classes. The IMSA Technical Regulation philosophy can be summed in the following concepts:

- Cars are constructed and regulated to a controlled standard, the vehicle Homologation.
- Modifications to the Car are not permitted unless specifically stated in the applicable class’s Technical Regulations.
- The Car, at all times, must adhere to:
 - The current Homologation Document(s) and valid extension documents (e.g., EVO).
 - The Manufacturer’s or Constructor’s Parts Manual.
 - Manufacturer submitted and IMSA approved declarations (where applicable).
 - The IMSA Technical Regulations for the Class
- Normal adjustment of the Car is permitted as defined by the applicable Car’s Homologation and Class’s Technical Regulations.
- Repair of the Car, parts, and components is permitted, provided it serves no additional purpose other than the repair itself. All such repairs must meet all Constructor / Manufacturer specifications and regulatory requirements.

(cont.)

Modifications by an Entrant to parts, systems, and/or components of the Car is not permitted for any reason. An Entrant wishing to perform any modification(s) must present modification(s) to the applicable Manufacturer or Constructor for formal approval from the applicable Homologating Authority for the Class. Entrants are not permitted to work directly with a Homologating Authority(s).

Entrants must have a current copy of the applicable Homologation for their Car Model at all times, as well as full access to the Manufacturer's / Constructor's Part Manual. Both of these documents together clearly identify the compliant specification of the Car and will be used as reference materials for both the Entrant and IMSA. A copy of the Homologation may be provided by the applicable Manufacturer / Constructor or purchased from the Homologating Authority.

IMSA's regulations work in conjunction with Homologation regulations from a Homologating Authority. This sometimes creates conflicts across the various regulation sets. Often the Homologating Authority has a combined set of Technical and Homologation regulations.

The hierarchy of these various regulations applies in descending order is as follows:

1. IMSA Class Technical Regulations and Bulletins
2. These IMSA Technical Regulations shall govern in any case where a conflict exists with the Homologation Regulations and Documentation.
3. Homologation Authority Technical Regulations and corresponding Homologation Form & Parts Book

Example 1: Incorrect process

A Team has found that a suspension part of the Car is prone to failure when going over large bumps. The Team chooses to resolve the problem on their own and modifies the part with components made in their own shop, which are not in the Homologation or Parts Manual of the Car. IMSA Technical Staff find this modification during a post-Race inspection. IMSA finds that the car is not in the approved configuration and the Entrant is penalized.

Example 2: Correct process

A Team suspects a part on the Car may be prone to failure during longer races. The Team therefore informs their Manufacturer or Constructor representative of their concern. The Manufacturer or Constructor agrees that a modification or redesign is appropriate and submits a written proposal with supporting documentation to the Homologating Authority for review. Upon approval the Homologation documents are updated and distributed for equitable customer awareness and part implementation.

Homologation Authority for the Class:

Class	Homologating Authority
TCR	WSC

EXECUTIVE LEADERSHIP MASTHEAD

John Bishop* / Bill France, Sr.*

Founders – IMSA

Dr. Don Panoz*

Legacy Vice Chairman

Jim France

Chairman

Lesa Kennedy

Director

Ed Bennett

Chief Executive Officer

John Doonan

President

Tracey Lesetar-Smith

Director and Legal Counsel

David Pettit

Senior Vice President, Marketing

Simon Hodgson

Vice President, Competition

Brandon Huddleston

**Vice President, Partnership Marketing
and Business Development**

***Deceased**

ARTICLE 1. DEFINITIONS SPECIFIC TO THE TECHNICAL REGULATIONS

- 1.1.1. **Car** means a singular representation of a Car Model entered by an Entrant in an Event.
- 1.1.2. **Car Model** means a specific model of a vehicle constructed by an IMSA-recognized Manufacturer Partner, and intended for Competition.
- 1.1.3. **Class** means a category for Cars sharing a common set of Homologation Regulations and differentiated from others by type of Car Model.
- 1.1.4. **Competition** means a contest of competitive nature in which a Car takes part during an Event and results of which Competition are published.
- 1.1.5. **Constructor** means an entity that designs and builds race car chassis.
- 1.1.6. **Entrant** means an entity or person who has entered a Car that has been accepted for Competition and holds an IMSA Membership in the capacity of an Entrant or Entrant/Driver.
- 1.1.7. **Event** means an IMSA Sanctioned motorsport activity. It includes the designated Race as well as all periods for registration, inspections, practice Sessions, qualifying Sessions, racing, pre- and post-Race activities and inspections, and rain or postponed dates related thereto.
- 1.1.8. **Homologate** means to execute the Homologation Process.
- 1.1.9. **Homologated** means a Car Model approved through the Homologation Process.
- 1.1.10. **Homologation** means the concept of all things associated with Homologation Authority approval via the Homologation Process.
- 1.1.11. **Homologation Authority** means an entity with the authority to Homologate.
- 1.1.12. **Homologation Documentation** means all files, documents, information, and communication associated with the issuance of official approval of Homologation.
- 1.1.13. **Homologation Identifier** means the unique identifier (generally including a string of characters identifying the Category or Class of Homologation followed by a sequential number assigned to the Car Model) serving as a reference to the official approval of Homologation, assigned by the Homologation Authority.
- 1.1.14. **Homologation Process** means all procedures associated with petitioning a Homologation Authority for approval that a Car Model complies with the Homologation Regulations.
- 1.1.15. **Homologation Regulations** means a set of technical requirements and criteria used to design, construct, and document a Car Model intended for racing in a specific category or class of racing.
- 1.1.16. **Manufacturer** means a Manufacturer Partner constructing an approved Car Model.
- 1.1.17. **Manufacturer Partner** means a recognized IMSA Official Automotive Partner.
- 1.1.18. **Specification** means all technical characteristics of the Car Model defined by the Homologation and Technical Catalog.
- 1.1.19. **Specific Homologation** means the Homologation specific to a particular Car Model.
- 1.1.20. **Technical Catalog** means IMSA's collection of data and documents supporting a Car Model
- 1.1.21. **Technically Eligible** means conforms to all technical requirements and criteria defined by these Technical Regulations.

ARTICLE 2. TECHNICAL PHILOSOPHY

2.1. Technical Eligibility

- 2.1.1. Cars representing a Car Model must always respect the Specification.
- 2.1.2. To be eligible for participation in this Class, a Car Model must:
 - a. Be a Car Model constructed by an IMSA-recognized Manufacturer Partner.
 - b. Hold a valid Homologation, approved and issued by an IMSA-recognized Homologation Authority.
- 2.1.3. IMSA is the sole authority to define the Technical Eligibility of a Car Model and issue the Technical Credential.

2.2. Changes

- 2.2.1. Changes to the Specification are prohibited, unless explicitly authorized by IMSA.
- 2.2.2. Manufacturers alone are permitted to petition IMSA to change the Specification; requests by Entrants are not recognized.

2.3. Conflict Resolution

- 2.3.1. These IMSA Technical Regulations shall govern in any case where a conflict exists with the Homologation Regulations and Documentation.

2.4. Final Authority

- 2.4.1. IMSA is the Final Authority with respect to these Technical Regulations.

2.5. Conditions for Use of a Specific Homologation

- 2.5.1. At all times during IMSA-sanctioned Events it is the Entrant's responsibility to ensure the configuration of the Car Model represents the Homologation components of the Specification; including:
 - a. As-Homologated Configuration
 - b. As-Delivered Configuration
 - c. Parts Manual
 - d. Homologation Extension Form Configuration
- 2.5.2. The original, As-Homologated Configuration of the Car Model must not be modified unless permitted by these Technical Regulations.
- 2.5.3. The As-Delivered Configuration of a Car must respect the as-received configuration from the Car Model Manufacturer, unless permitted by these Technical Regulations.
- 2.5.4. The Parts Manual is the official parts catalog for the Car Model as defined by the Car Model Manufacturer or Constructor:
 - a. Specific parts listed in the Parts Manual must be used on all representations of a Car Model unless permitted by these Technical Regulations.
- 2.5.5. To be eligible for use in any IMSA-sanctioned Event, modifications detailed in Homologation Extension Forms must:
 - a. Be approved by, or have initiated the process to obtain approval from, the Homologation Authority, and appended to the Car Model Homologation.
 - b. Be approved by IMSA.
 - c. Be available to all Entrants of the relevant Homologated Car for the next Event.

ARTICLE 3. TECHNICAL TESTING AND VERIFICATION

- 3.1.1. IMSA may request Manufacturers submit reference components, tooling, and/or templates to the IMSA Technical Department
 - a. IMSA may retain these components without compensation.
 - b. Manufacturers are responsible for all costs as related to submitting reference components.
 - c. Fees may apply.

3.2. Technical Testing

- 3.2.1. Testing conducted by IMSA; may be performed including, but not limited to:
 - a. Restrictor Flow
 - b. Engine Dyno
 - c. Wind Tunnel
 - d. On-track Testing
 - e. Refueling Testing
- 3.2.2. Testing and associated costs are the responsibility of the applicable Manufacturer or Constructor.

ARTICLE 4. BALANCE OF PERFORMANCE

4.1. Balance of Performance

- 4.1.1. IMSA may, at its discretion, utilize an adjustment method to maintain competitive equivalency between Cars within each Class, and between Classes.
 - a. Details of the Balance of Performance Process are described in Attachment 2 of the applicable Sporting Regulations.
- 4.1.2. Technical Bulletins are an extension of these Regulations and part of the Rules.
- 4.1.3. Providing false or intentionally misleading information is a breach of these Technical Regulations

ARTICLE 5. SAFETY

5.1. Driver Safety Harness System

- 5.1.1. Cars must be equipped with a minimum 6-point Driver safety harness with a valid label demonstrating compliance with one of the following standards:
 - a. FIA Standard 8853/98: FIA Safety Harnesses Standard
 - i. [FIA Technical List #24](#): Harnesses Homologated by the FIA according to the FIA Standards 8853/98 and 8854/98
 - b. FIA Standard 8853-2016: Safety Harnesses
 - i. Mandatory on Car Models Homologated in 2020 and newer.
 - ii. [FIA Technical List #57](#): Harnesses Homologated according to the FIA Standard 8853-2016
- 5.1.1. Installation must be performed in accordance with instructions provided by the system supplier and/or manufacturer.
 - c. Belt components must be installed at each Homologated anchor point to prevent accidental release or opening.
 - d. Individual belt straps must be independent; any method or attempt to combine individual straps is prohibited.
 - e. Elastic retention straps are prohibited on shoulder belts
- 5.1.2. Harnesses must be replaced at the request of IMSA, or whenever the following conditions occur:
 - a. Expiration:
 - i. FIA Homologated: Immediately following December 31st of the year printed on the label.
 - b. Damage:
 - i. Following a severe collision.
 - ii. Webbing is cut or frayed, or weakened due to actions of chemicals or sunlight.
 - iii. Buckles are bent, deformed, rusted, or improperly functioning.
- 5.1.3. Entrants are responsible for ensuring the Driver safety harnesses and all associated components are properly labeled, installed, used, and maintained.
- 5.1.2. Belt components must be used as designed by the manufacturer. It is prohibited to mix belt components between manufacturers or certifications.

5.2. Seat

- 5.1.3. As Homologated

5.3. Driver Containment Nets

- 5.3.1. As Homologated
- 5.3.2. Installation requirements:
 - a. Supplier and/or manufacturer installation instructions must be respected.
 - b. Horizontal webbing must be oriented towards the Driver.
 - c. When secured at anchor points, nets must be:
 - i. Oriented parallel to the Car centerline.
 - ii. Located with minimal gap to the Driver's helmet.
 - d. Signage or equipment may be attached to nets provided:
 - i. The designed purpose of the net is respected.
 - ii. Visibility over and/or through the net is unobstructed.
- 5.3.3. Containment nets must be replaced prior to the expiration date:
 - a. FIA Homologated: Immediately following December 31st of the year printed on the label.

5.4. Protective Padding

- 5.4.1. Cars must be equipped with non-flammable protective padding with a valid label demonstrating compliance with one of the following standards:
 - a. FIA Standard 8857-2001: FIA Roll Cage Padding Standard
 - i. [FIA Technical List #23](#): Roll Cage Padding Homologated by the FIA
 - b. SFI Specification 45.1: Roll Cage Padding
 - i. [Specification](#)
 - ii. [Manufacturers](#)
- 5.4.2. Installation requirements:
 - a. Padding must be located to protect the Driver (body and/or helmet) against direct contact with the safety cage in a collision.
 - b. Protective padding must be securely affixed to prevent rolling or displacement.

5.5. Master Electrical Switches

- 5.6.1. As Homologated
- 5.6.2. Systems must remain functional during any on-track activity or at the request of IMSA.
- 5.6.3. Interior and exterior master switches must be clearly identified by a self-reflective symbol of a red spark surrounded by a white-edged, blue triangle with a base greater than 30 mm.

5.6. Fire Suppression System

- 5.6.1. As Homologated
- 5.6.2. Identification
 - a. Exterior activation mechanism must be marked with a self-reflective symbol with a red edge surrounding a red "E" inside a white circle at least 100 mm in diameter.
- 5.6.3. Inspection
 - a. IMSA may require removal of the fire bottle for Technical Inspection.
 - b. Entrant is responsible to demonstrate proper system function of the interior and exterior fire suppression activation mechanisms, using the "test" mode if present.

ARTICLE 6. DEFINITION OF CLASS

6.1. TCR

- 6.1.1. Class Structure: TCR cars compete in the TCR Class of the IMSA Michelin Pilot Challenge (IMPC).
- 6.1.2. Eligibility Requirements: To be eligible for participation in the Class, a Car Model must respect the Specification defined by the Homologation and Technical Eligibility requirements:
- a. Homologation (TCR):

Homologation Authority:	World Sport Consulting Inc. (WSC)
Homologation Specification:	World Sport Consulting Inc. (WSC) Group TCR
Homologation Regulations:	WSC Group TCR Technical Regulations

ARTICLE 7. VEHICLE SYSTEMS

7.1. General

- 7.1.1. All Vehicle Systems and associated sub-systems are listed in this Article.
- a. Where change to these Vehicle Systems is permitted, regulatory text is **bold and underlined**.
- b. Where change to these Vehicle Systems is prohibited, regulatory text is light grey.
- c. Advisory statements are in normal text.

7.2. Modifications to the Specification

- 7.2.1. Entrants are permitted to execute the following changes to parameters defined by the Homologation component of the Car Model Specification, provided these Technical Regulations, all current Technical Bulletins, and the Technical Credential are fully respected:
- a. Adjust component settings defined as adjustable.
- b. Replace components with parts defined as optional.
- 7.2.2. Manufacturers must make any declarations listed in these Technical Regulations in the Technical Eligibility Form.
- 7.2.3. Further authorization to modify the Specification and/or As-Delivered Condition is granted via the following formal communication methods:
- a. Published IMSA Technical Bulletin
- b. IMSA Technical Committee Bulletin
- 7.2.4. Informal and/or verbal communication is not considered valid authorization.

7.3. Servicing, Repair, and Replacement

- 7.3.1. All servicing or repair must be made in good faith to restore the Car and all components to their originally intended form and function as defined by the Specification.
- 7.3.2. Entrants may replace damaged or worn components provided these Technical Regulations are respected.

7.4. Dimensions

- 7.4.1. General
- a. IMSA's calibrated measurement instruments are the official measurement instruments.
- b. Scrutineering measurement(s) are taken with the applicable dry-type tire set installed.
- i. Tire compound per the applicable Event SR.
- c. Tire pressure shall be set at 30.0 psi (± 0.5 psi) for scrutineering measurement(s).
- 7.4.2. Reference Surface
- a. The lowest plane of the underside of the Car is measured to the Technical Inspection scale plane.

7.4.3. Mass

- a. The minimum mass for all Car Models is defined via Balance of Performance Tables and associated Technical Bulletins.
- b. Car mass is measured as-raced minus Driver and Fuel using the IMSA scales during Technical Inspection.

7.4.4. Ballast

- a. **Entrants are permitted to add or remove ballast to achieve minimum mass:**
 - i. Ballast must be in plate or panel form.
 - ii. Addition or removal of ballast during the race is prohibited.

7.4.5. Minimum Ride Height

- a. The minimum ride height for all Car Models is defined via Balance of Performance Tables and associated Technical Bulletins.

7.4.6. Overall Dimensions

7.5. Chassis

7.5.1. General

- a. **Entrants are permitted to execute minimum modifications for the installation of approved components.**
 - i. All modifications must be approved by IMSA

7.5.2. Air Jack System

- a. Air Wand Receptacle
 - i. **Air wand receptacles are permitted to be repositioned symmetrically about the longitudinal axis of the car unless alternate mounting locations are specifically identified in the Homologation Document**

7.6. Driver Interface

7.6.1. General

7.6.2. Steering Wheel

7.6.3. Pedal Box

- a. **Entrants are permitted to apply non-slip adhesives to the surface of driver pedals**

7.6.4. Shifting Mechanism

7.6.5. Driver Adjustable Components

7.6.6. Driver Cooling Systems

- a. **Entrants are permitted to install a maximum of two (2) Driver Cooling Systems, i.e. Cool Suits.**
 - ii. Driver cooling systems must use non-flammable refrigerant (e.g. R134a, water).
- b. Installations must meet the following conditions:
 - i. The mounting location and installation for the primary system is unrestricted provided it serves no purpose other than retaining the cooling system in the event of a collision.
 - ii. Any secondary driver cooling system must be mounted on the top of the ballast box.
 - iii. All driver cooling system components must be securely mounted.
 - iv. The use of hook and loop fasteners (Velcro) is prohibited.

c. Entrants are permitted to install Driver Ventilation Ducts

- i. A NACA duct is permitted to be installed on the side window, rear quarter window, OR the rear window for the purpose of cooling the driver
- ii. Maximum of 1 per side with 2 ducts permitted per car
- iii. Maximum cutout area of 26 cm x 16 cm
- iv. No duct shall break the outward plane of the surface on which it is installed
- v. Ducts must be translucent
- vi. Duct and/or hoses must not impede cockpit exit or driver's visibility
- vii. System may include the substitution of non-Homologated for parts for Homologated parts.

7.7. Bodywork**7.7.1. General****a. Entrants are permitted to install the following films to the front windscreen:**

- i. Tear-off
- ii. Anti-fog

7.7.2. Bodywork Seams**a. Entrants are permitted to apply tape or vinyl around refueling receptacle seams and/or rear wing end fence adjustment holes.****7.7.3. Decals**

- a. Entrants are permitted to apply removable die cut sponsorship decals with the approval of IMSA.
- b. Windows must remain free of decals and/or tint unless required by IMSA

7.8. Aerodynamic Elements**7.8.1. General**

- a. Manufacturer seals must be respected

7.8.2. Splitter**7.8.3. Dive Planes****7.8.4. Body Gurney****7.8.5. Wings****7.8.6. Rear Wing Gurney****7.8.7. Floor****7.8.8. Friction Blocks****7.8.9. Diffuser****7.9. Engine System****7.9.1. General****7.9.2. Engine****7.9.3. Oiling System**

- a. Approved lubricants are permitted to be utilized.

7.9.4. Lambda**7.9.5. Engine RPM****7.9.6. Intake****7.9.7. Exhaust****7.9.8. Turbo**

7.9.9. Engine Control Unit (ECU)

7.9.10. Engine Transportation Crate

- a. Entrant must have immediately available a crate sufficient to securely and safely package and ship an engine.

7.10. Boost Management

7.10.1. Maximum Boost Pressure

7.10.2. Boost Pressure Ratio

7.10.3. Boost Control Strategy Inputs

- a. Per WSC Regulations

7.10.4. Calculation Method

- a. Per WSC Regulations

7.11. Drive System

7.11.1. General

- a. Manufacturer seals must be respected

7.11.2. Fluids & Lubricants

- a. Unrestricted.

7.11.3. Clutch

7.11.4. Gearbox

7.11.5. Gears

7.11.6. Gearbox Control Unit

7.11.7. Differential

7.11.8. Axles

7.11.9. Uprights

7.12. Cooling System

7.12.1. General

7.12.2. Fluids

- a. **Entrants are permitted to utilize the following approved cooling fluids:**

- i. Water
- ii. Air
- iii. Non-glycol based fluids

7.12.3. Inlet Blockers

7.12.4. Water System

7.12.5. Oil Cooling System

7.13. Fuel System

7.13.1. General

- a. Maximum Capacity

- i. The maximum fuel capacity for all Car Models is defined via Balance of Performance Tables and associated Technical Bulletins.
- ii. The maximum fuel capacity is the total volume of fuel contained in the Car.

7.13.2. Fuel Types

- a. The approved fuel for the Class is IMSA E10, as supplied by VP Fuels.
 - i. IMSA may require a fuel sample for inspection via a gas chromatograph.

7.13.3. Fuel Cell

- a. **Entrants must use blocks or balls to achieve maximum fuel cell capacity:**
 - i. Any device, system, or procedure designed to increase, even temporarily, the total fuel storage capacity beyond the maximum is prohibited.
- b. Any configuration of the Homologated design intended to decrease the minimum refueling time below the minimum time listed in the class specific BoP table is prohibited.

7.13.4. Fuel Lines

7.13.5. Fuel Sample Port

7.13.6. Refueling Receptacle

7.14. Brake System

7.14.1. General

7.14.2. Fluids & Lubricants

- a. Unrestricted.

7.14.3. Bias Assembly

7.14.4. Master Cylinders

7.14.5. Brake Lines

7.14.6. Calipers

7.14.7. Rotors

7.14.8. Pads

- a. **Friction material is unrestricted.**
- b. Backing Plates must be ferrous.

7.14.9. Ducting

7.14.10. Brake Duct Inlet Blockers

- a. **Entrants are permitted to apply opaque adhesive tape to block off portions of the brake duct inlet openings.**

7.14.11. Anti-Lock Braking System

7.15. Steering System

7.15.1. General

7.15.2. Fluids & Lubricants

- a. Unrestricted.

7.16. Suspension System

7.16.1. General

7.16.2. Geometry Elements

7.16.3. Springs

- a. Spring rates are unrestricted

7.16.4. Dampers

- a. **Valving is permitted to be changed**
- b. Inerters technology is prohibited.

7.16.5. Bump Rubbers and Packers

- a. Unrestricted.

7.16.6. Anti-Roll Bar

7.16.7. Third Elements

7.17. Wheels & Tires

7.17.1. General

7.17.2. Wheels

7.17.3. Wheel Attachment

7.17.4. Tires

- a. The approved tire supplier for this Class is Michelin.
- b. Tires must be used in accordance with SSR Attachment 3.

7.18. Electronics

7.18.1. General

7.18.2. Data Logger

- a. **Entrants are permitted to install a data acquisition system.**
- b. IMSA reserves the right to download and/or view all logged data at any time.

7.18.3. Telemetry

- a. Telemetry is prohibited.

7.18.4. Wiring Loom

- a. All data acquisition equipment must use a separate visible and traceable wiring loom.

7.18.5. Sensors

- a. **Entrants are permitted to install the following approved sensors/inputs:**
 - i. One longitudinal and one lateral G load sensor
 - ii. Front and/or rear brake pressures
 - iii. Wheel speed sensors (maximum 4)
 - iv. Steering input
 - v. Throttle position
 - vi. Water Temperature
 - vii. Oil Pressure
 - viii. Oil Temperature
 - ix. Gearbox Temperature
 - x. Differential (or Rear End) Temperature
 - xi. Fuel Pressure
 - xii. GPS
 - xiii. CAN Interface
 - xiv. Manifold Pressure / Vacuum (Mandatory on cars with Forced Induction)

7.18.6. Radio

- a. **Entrants are permitted to install a single two-way voice radio with car-to-pit communication capability in compliance with the corresponding Series Sporting Regulations.**

7.18.7. Rear View Camera

- a. **Where not homologated, Entrants are permitted to install a rear-view camera system.**
- b. Rear view camera system must:
 - i. Be freestanding without connection(s) to other system(s).
 - ii. Utilize wired connections (i.e. wireless transmission prohibited)
 - iii. Camera and related equipment must use a separate visible and traceable wiring loom.
- c. Installation and type of rear view camera system must be officially approved in writing by IMSA a minimum of seven (7) days prior to unloading for an Event.

7.18.8. Auxiliary Power Sources

ARTICLE 8. SERIES REQUIRED ELECTRONICS

8.1. Series Scrutineering Data System

8.1.1. Cars not utilizing the TCR Spec ECU must be equipped with the global TCR spec Aim Evo5 system.

- a. Cars must use and install the harness as supplied.
- b. Power lead shall remain on as long as the master kill is switch is on.
- c. Entrant is responsible for the proper installation, operation, and safe handling of all Series Scrutineering Data System Components. Verification data for the functionality of the scrutineering logger is transmitted via CAN message.
- d. Series Scrutineering Logger must be fully functional when on-track
- e. SD Cards are property of IMSA and shall be distributed once load-in is complete
- f. Configurations (CAN, Logger, etc) must be used as delivered for the specific car model
- g. Entrant is responsible to maintain an adequate inventory of replacement parts to ensure the system is fully functional.

8.1.2. System Parts List

Memotec Part #	Description	Qty
evo5-TCR	Complete TCR Datalogger Kit	1
varies	Memotec Harness per manufacturer	1
	Individual components	
Evo5logger	evo5 Logger without accessories	1
evo5-KBSDL	Wiring harness evo5, 37 pin, SDL	1
GPS-08L	GPS-08 with 4000 mm cable length	1
M21E003	USB-Adapter 719 4-p - Mini USB	1
M-HGTM	Holder kit for SDL Logger	1
V26Z943	Pressure sensor 0 - 3 bar absolute, 711	1
M13ZL11S	IR Receiver, 711	1
M22-FIA	CAN Connection cable, SDL, FIA, DTM06-6S	1

8.1.3. Series Scrutineering Data System collection requirements:

- a. Entrants must present all series mandated data collection media to the IMSA Technical Inspection trailer within thirty (30) minutes of the completion of each session.
 - i. For sessions within one (1) hour of one another, Data shall not be required to present after the first session.

8.2. Safety Light System

8.2.1. Cars must be equipped with the Delphi Yellow Light Kit to indicate active flag status.

- a. The Kit contains the following components:
 - i. Yellow Indicator Light
 - ii. Mounting Bracket
 - iii. Antenna
 - iv. Wiring Loom and Instructions

8.2.2. The Safety Light system must be installed and functioning during on-track activity.

- a. The Yellow Indicator Light must be prominently installed within the cockpit, in clear line of sight of the driver.
- b. Antenna Installation: The supplied antenna must be mounted:
 - i. On the Car roof
 - ii. Away from other antennae
 - iii. Following the diagram below (a ground plane is not required):

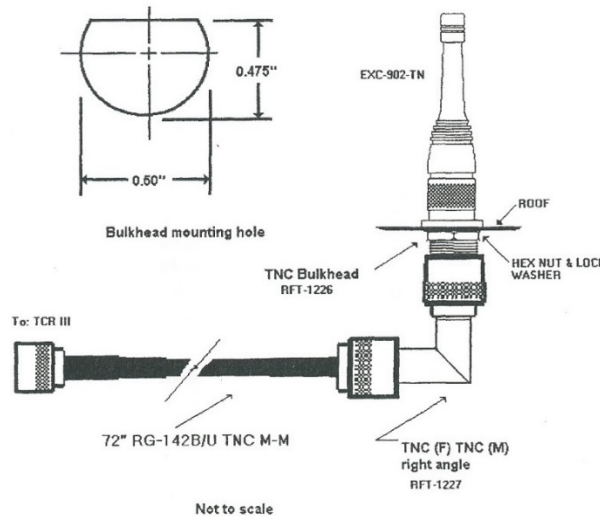

- c. Wiring Loom Installation: The Wiring Loom has a flying lead input for +12 VDC and Ground to interface with additional wiring referenced in the installation instructions.
 - i. Entrants must supply additional wiring as required.

8.2.3. An activating receiver is available from IMSA during Safety Checks at each Event and remains the property of IMSA.

- a. Entrants must surrender the receiver when required by IMSA.
- b. A lost or damaged receiver is subject to a replacement fee referenced in the IMSA Accessories form

8.3. Driver ID System

8.3.1. Cars must be equipped with the MoTec Driver ID Module # RG OTC

- a. Available for purchase through MoTec

8.3.2. Entrant must supply Driver ID Plugs

- 8.3.3. Female Driver ID plug(s), (i.e., Driver #1 through Driver #5) may be installed inside the Car cockpit or attached to the individual Drivers' helmets.
 - a. Alternative installations must be approved by IMSA.
- 8.3.4. Transponder and plugs must operate to the satisfaction of the Timing and Scoring Officials.

8.4. X2 Transponder System

- 1.1.2. Installation of the X2 system must be in accordance with the IMSA Approved, Manufacturer submitted Series Electronics Declaration Form added to the Technical Credential.
 - a. Series Electronics Declaration Form is available from the respective Manufacturer Partner.
- 8.4.1. Cars must be equipped with the X2 Transponder System Kit
 - a. Kit contains the following components:
 - i. X2 Transponder
 - ii. Isolation Mounts
 - b. Entrant must supply the following additional item(s):
 - i. X2 Transponder Mounting Bracket (available for purchase as listed in the IMSA Accessories Order Form).
 - ii. M4 Socket Head Cap Screw and Washer.
- 8.4.2. X2 transponder may be purchased via the IMSA Accessories Order Form.:
- 8.4.3. Transponder and plugs must operate to the satisfaction of the Timing and Scoring Officials.
- 8.4.4. Transponder consumes less than 300 mA (10-15 VDC), and must:
 - a. Be a fused, 12-volt DC configuration
 - b. Meet the specifications defined by ISO 7637

8.5. Leader Light System

- 8.5.1. Cars must be equipped with LED leader light panels as follows:
 - a. MoTec Leader Light Panels # PV0091
 - b. MoTec Harness
- 8.5.2. Leader light system must be installed and functioning during the Event
 - b. System must be installed in accordance the Manufacturer submitted, IMSA Approved, Series Electronics Declaration Form
 - c. Series Electronics Declaration Form is available from the respective Manufacturer Partner.
- 1.1.3. IMSA Leader Lights are available from MoTec USA (https://www.milspecwiring.com/IMSA-Michelin-Pilot-Challenge_c_937.html)
- 8.5.3. Leader Lights consume less than 4.5 A (10-15 VDC), and must:
 - i. Be a fused, 12-volt DC configuration
 - ii. Meet the specifications defined by ISO 7637

8.6. Back-lit Panel

Not Applicable

8.7. Pro-Am Light

Not Applicable

8.8. In-Car Camera

Not Applicable

ARTICLE 9. REFUELING SYSTEM

9.1. Fuel Transfer

- 9.1.1. Fuel may be transferred from the autonomous supply tank to the Car using the equipment and methods defined in this Article.
- a. Approved equipment as defined herein must be:
 - i. Unmodified.
 - ii. Installed and operational.
 - b. Approved method:
 - i. Gravity.
- 9.1.2. Fuel transferred to the autonomous supply tank must be delivered by means of a hose fitted with a self-sealing connector (e.g. dry break, cam-lock) connected to the autonomous supply tank.

9.2. Pit Tank

- 9.2.1. Construction of the Autonomous Supply Tank must:
- a. Comply with FIA Appendix J Drawing n° 252-7 with the exception of the top plate shape and dimensions.
 - b. Not have sensors other than as required by IMSA.
- 9.2.2. Refueling tank height is measured from the top surface of the vessel, not including vent, cover plate or fasteners, at a distance of 1.25 meters from the outermost face of the pit wall
- 9.2.3. The required refueling tank height is 2.0 meters with a tolerance of +0/-1.0 cm.
- 9.2.4. Once inspected by an IMSA Official the Autonomous Supply Tank, Trolley, Peripheral Connections, and Restrictor must remain as inspected with all IMSA seals intact until the conclusion of the Race or upon an approved retirement via MERG.

9.3. Peripheral Connections

- 9.3.1. Tanks must be equipped with the IMSA-specified peripheral connections between the tank outlet and the refueling hose.
- a. Parts must be purchased from RPXpress:

Part Number	Part	Description
BSR-FR FN40	Outlet Flange	Bottom Tank 12-bolt housing
ATL-TF 147	12-Bolt Gasket	
BSR.FR.R.35GOLD	35.0mm Restrictor	Upper Restrictor (for positive seal to Elbow)
BSR-FR 1981	Bottom 80 deg. Elbow	Female Camlock x 2" Male
BSR.P.5K56.SS	Restrictor Housing	Deadman Outlet, 2" Male to 1 1/2" Camlock
BSR.P.5K.RPX.SS	Hose Coupler	1.5" OD barb to Deadman outlet
1 Deadman Valve:		
BSR-FR-R003	Deadman Valve (new design)	Stainless Deadman Valve
BSR-FR-R002	Deadman Valve (old design)	Brass Deadman Valve

a. Refueling System Assembly Illustration:

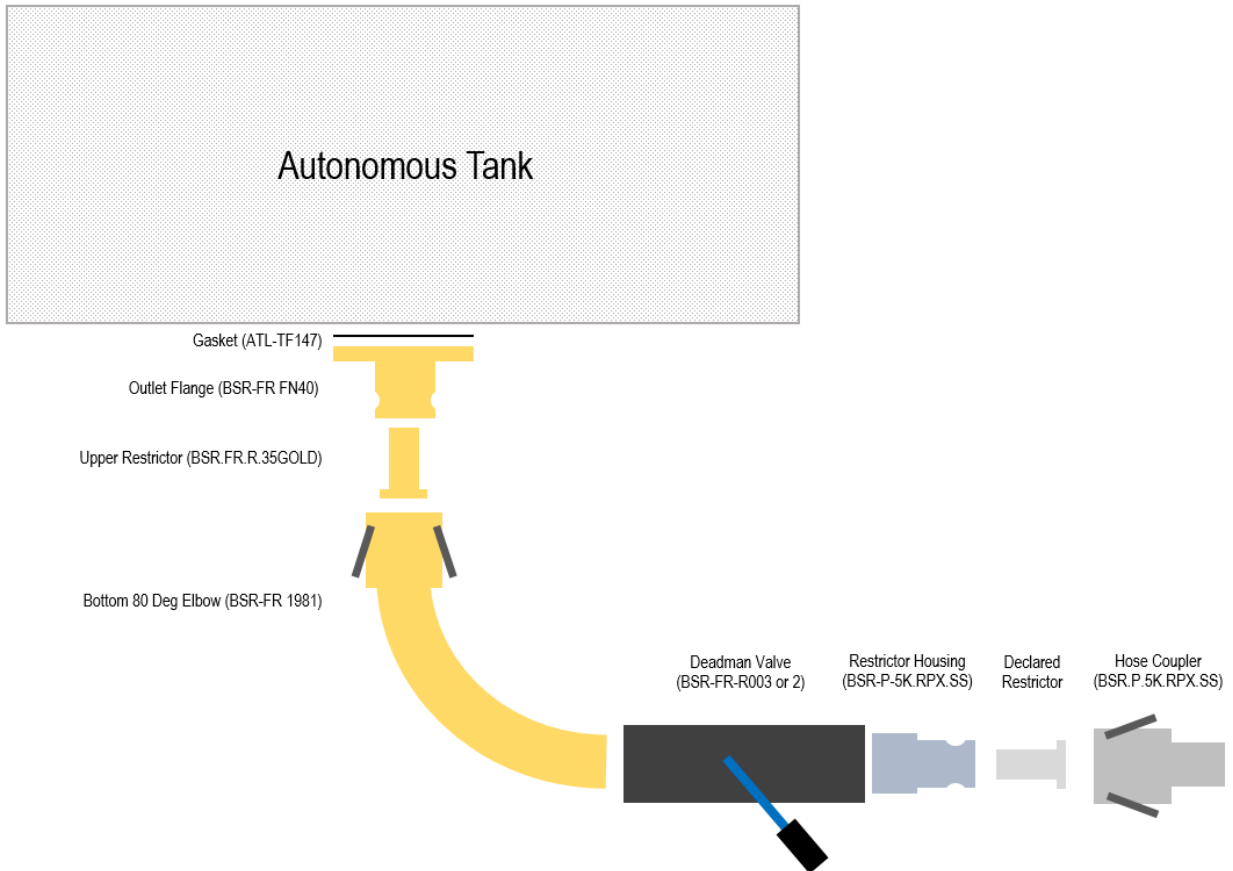

- 9.3.2. Deadman valve and bottom 80 deg. elbow assembly must be securely braced to remain attached to the tank in the event of an incident.
 - a. Mechanisms preventing normal operation of the deadman valve are prohibited.
 - b. Any configuration of the IMSA-mandated design intended to decrease the minimum refueling time below the minimum time listed in the class specific BoP table is prohibited.
 - c. During fuel delivery operations, the deadman valve must be fully open such that the throat of the ball is aligned axially with the outlet of the deadman valve body with the actuation handle fully extended.
 - i. Adjustment mechanisms will be sealed by IMSA.
- 9.3.3. During refueling the air vent outlet must be connected using an appropriate coupling to the tank.
- 9.3.4. A sight glass may be installed to the outside of the supply tank, and must be equipped with isolating valves mounted as close as possible to the tank.

9.4. Refueling Hose

- 9.4.1. Refueling/vent hoses must have one end equipped with a self-sealing connector to fit the autonomous supply tank outlet.
- 9.4.2. Refueling/vent hoses are permitted to be protected for the sole purpose of resisting abrasion damage.
 - a. Cover must be easily removable by means of full-length Velcro or zipper.
 - b. Cover must be non-reflective
- 9.4.3. Hose maximum inside diameter
 - a. Dual-Port systems must be less than 1.5 inches for all hoses.
 - b. Single-Port (coaxial) systems must be less than 1.5 inches for Refueling Hose and less than 75.0 mm for the vent hose

- 9.4.4. Refueling hose minimum length must be greater than 4.0 m
- a. Minimum length is measured from the most distant plane of the dry break/fuel probe to the most distant plane of the Hose Coupler.

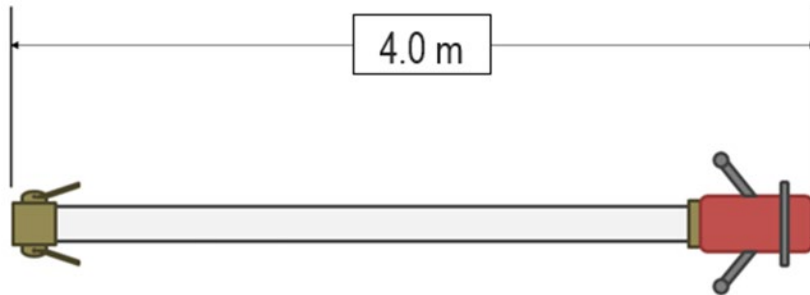

9.5. Tank Support Stand

- 9.5.1. The tank must be attached to one of the following:
- a. To a trolley meeting the following requirements:
 - i. All tower components must be assembled without any degree of freedom in relation to the trolley.
 - ii. Have a surface area greater than two (2) square meters.
 - iii. Utilize four (4) self-braking casters.
 - iv. Be ballasted with weight exceeding that of the tank when filled with fuel.
 - b. Scissor style (X-brace) stand
- 9.5.2. Trolley is permitted to have load sensors for the sole purpose of weighing fuel in the Autonomous Tank.

9.6. Boom

Not Applicable

9.7. Refueling Restrictor

- 9.7.1. During refueling, all fuel entering the Car must pass through the refueling restrictor.
- 9.7.2. Refueling Restrictor must meet the following criteria:
- a. Material must be an aluminum alloy.
 - b. Must comply with the IMSA Fuel Restrictor Part Drawing at the end of these Technical Regulations
- 9.7.3. Refueling restrictors may be purchased from RPXpress (Phone: +1-828-428-0820 Email: lmcelwain@rpxpress.com).
- 9.7.4. At each Event, every Entrant must declare their chosen diameter, limited to 16 mm to 35 mm in 0.25 mm increments, by completing the [IMSA Refueling Restrictor Declaration Form](#) prior to 7:00 PM Local Time two (2) days before race day.
- 9.7.5. IMSA may utilize the following scrutineering inspection methods to check minimum refueling times:
- a. Vehicle data system.
 - b. Video review.
 - c. Minimum Refueling Time Audit (Reference: SSR 37.10).
- 9.7.6. Refueling Restrictors are sealed by IMSA Technical Officials.
- a. Entrants must receive written approval from IMSA to remove seals following inspection, and seals must be replaced by IMSA Technical Officials prior to on-track activity.
 - b. The following bolts must be drilled for safety-wire sealing of the restrictor
 - i. Two (2) adjacent Bolt heads of the Restrictor Housing
 - ii. Two (2) Hinge Bolts (threaded section) of the Outlet Pipe Cam Lock
 - iii. Two (2) Lock Lever Arms of the Refueling Hose Cam Lock

- iv. A 0.125 inch hole must be drilled in the two female camlock levers on the bottom 80 deg. elbow assembly 0.5 inches below pin in the locations indicated in yellow on the diagram below:



9.8. Autonomous Tank Sensor System

Not Applicable

