

2024 TECHNICAL REGULATIONS

Revision Date: 11/29/2023



Series:

IMSA WEATHERTECH SPORTSCAR CHAMPIONSHIP



Class:

LE MANS PROTOTYPE 2



Sanctioned by:

**INTERNATIONAL
MOTOR SPORTS
ASSOCIATION**

One Daytona Blvd.
Daytona Beach, FL 32114
(O) +1 (386) 310-6500
(F) +1 (386) 310-6695
www.imsa.com



Table of Contents

Foreword:	3		
ARTICLE 1. DEFINITIONS SPECIFIC TO THE TECHNICAL REGULATIONS	6		
ARTICLE 2. TECHNICAL PHILOSOPHY	6		
2.1. Technical Eligibility	6		
2.2. Changes	7		
2.3. Conflict Resolution	7		
2.4. Final Authority	7		
2.5. Conditions for Use of a Specific Homologation	7		
ARTICLE 3. TECHNICAL TESTING AND VERIFICATION	7		
3.1. Reference Components	7		
3.2. Technical Testing	7		
ARTICLE 4. BALANCE OF PERFORMANCE	8		
4.1. Balance of Performance	8		
ARTICLE 5. SAFETY	8		
5.1. Driver Safety Harness System	8		
5.2. Seat	8		
5.3. Driver Containment Nets	8		
5.4. Protective Padding	8		
5.5. Master Electrical Switches	8		
5.6. Fire Suppression System	9		
ARTICLE 6. DEFINITION OF CLASS	9		
6.1. Le Mans Prototype 2 (LMP2)	9		
ARTICLE 7. VEHICLE SYSTEMS	9		
7.1. General	9		
7.2. Modifications to the Specification	9		
7.3. Servicing, Repair, and Replacement	10		
7.4. Dimensions	10		
7.5. Chassis	10		
7.6. Driver Interface	10		
7.7. Bodywork	11		
7.8. Aerodynamic Elements	11		
7.9. Engine System	12		
7.10. Boost Management	12		
7.11. Drive System	12		
7.12. Cooling System	13		
7.13. Fuel System	13		
7.14. Brake System	13		
7.15. Steering System	14		
7.16. Suspension System	14		
7.17. Wheels & Tires	14		
7.18. Electronics	15		
ARTICLE 8. SERIES REQUIRED ELECTRONICS	15		
8.1. General	15		
8.2. Series Scrutineering Data System	15		
8.3. Marshalling Display System	15		
8.4. Driver ID System	15		
8.5. X2 Transponder System	16		
8.6. Leader Light System	16		
8.7. Back-lit Panel	16		
8.8. Pro-Am Light	16		
8.9. Rain Light	16		
8.10. In-Car Camera	17		
8.11. Incident Data Recorder	17		
ARTICLE 9. REFUELING SYSTEM	17		
9.1. Fuel Transfer	17		
		9.2. Pit Tank	17
		9.3. Peripheral Connections	17
		9.4. Refueling/Vent Hoses	18
		9.5. Autonomous Tank Support Stand	19
		9.6. Boom	19
		9.7. Refueling Restrictor	19
		9.8. Autonomous Tank Sensor System	20
		9.9. Scrutineering Fuel Collection	21

Foreword:

For all Members, the IMSA RULES of the International Motor Sports Association establish the foundation for the organization and conduct of all IMSA Sanctioned Events. The IMSA RULES take effect immediately upon publication.

The purpose of the RULES is to: (i) promote safety, the sport of automobile Competition and IMSA, (ii) enhance Competition, (iii) ensure the quality, fairness and integrity of the IMSA programs and operations and (iv) achieve prompt finality in the Competition results (“**Purpose**”).

ALL MEMBERS ARE REQUIRED TO REVIEW THESE IMSA RULES CAREFULLY.

The **IMSA RULES** consist of following three (3) sections and the Event Supplementary Regulations (**SR**):

- The Technical Regulations, which outline the rules and regulations for the specific cars and equipment. The Technical Regulations may be modified or changed at any time by the publication of a Technical Bulletin, amending the Technical Regulations.
- The IMSA Sporting Regulations (**ISR**), which concern Competitor and Event procedures, as well as guidelines for the safe and uniform operation of the sport. The ISR may be modified or changed at any time by the publication of a Competition Bulletin, amending the ISR.
- The Series Supplementary Regulations (**SSR**) that provides Series-specific information about each IMSA Series. The SSR is integrated into the ISR and are designated with “(SSR)” next to the Paragraph title. The SSR may be modified or changed at any time by the publication of a Competition Bulletin, amending the SSR.

Any portion of the RULES may be modified through Bulletins (Competition Bulletins and Technical Bulletins, respectively) and takes force when published. Once published, the Bulletin shall take precedence over the applicable portion of the RULES. Additionally, the RULES may be modified for an Event by the Race Director through the mandatory briefing instructions.

HOW TO READ THE RULES

IMSA Technical Regulations follow a common philosophy across all Classes. The IMSA Technical Regulation philosophy can be summed in the following concepts:

- Cars are constructed and regulated to a controlled standard, the vehicle Homologation.
- Modifications to the Car are not permitted unless specifically stated in the applicable class’s Technical Regulations.
- The Car, at all times, must adhere to:
 - The current Homologation Document(s) and valid extension documents (e.g., EVO).
 - The Manufacturer’s or Constructor’s Parts Manual.
 - Manufacturer submitted and IMSA approved declarations (where applicable).
 - The IMSA Technical Regulations for the Class
- Normal adjustment of the Car is permitted as defined by the applicable Car’s Homologation and Class’s Technical Regulations.
- Repair of the Car, parts, and components is permitted, provided it serves no additional purpose other than the repair itself. All such repairs must meet all Constructor / Manufacturer specifications and regulatory requirements.

(cont.)



Modifications by an Entrant to parts, systems, and/or components of the Car is not permitted for any reason. An Entrant wishing to perform any modification(s) must present modification(s) to the applicable Manufacturer or Constructor for formal approval from the applicable Homologating Authority for the Class. Entrants are not permitted to work directly with a Homologating Authority(s).

Entrants must have a current copy of the applicable Homologation for their Car Model at all times, as well as full access to the Manufacturer's / Constructor's Part Manual. Both of these documents together clearly identify the compliant specification of the Car and will be used as reference materials for both the Entrant and IMSA. A copy of the Homologation may be provided by the applicable Manufacturer / Constructor or purchased from the Homologating Authority.

IMSA's regulations work in conjunction with Homologation regulations from a Homologating Authority. This sometimes creates conflicts across the various regulation sets. Often the Homologating Authority has a combined set of Technical and Homologation regulations.

The hierarchy of these various regulations applies in descending order is as follows:

1. IMSA Class Technical Regulations and Bulletins
2. These IMSA Technical Regulations shall govern in any case where a conflict exists with the Homologation Regulations and Documentation.
3. Homologation Authority Technical Regulations and corresponding Homologation Form & Parts Book

Example 1: Incorrect process

A Team has found that a suspension part of the Car is prone to failure when going over large bumps. The Team chooses to resolve the problem on their own and modifies the part with components made in their own shop, which are not in the Homologation or Parts Manual of the Car. IMSA Technical Staff find this modification during a post-Race inspection. IMSA finds that the car is not in the approved configuration and the Entrant is penalized.

Example 2: Correct process

A Team suspects a part on the Car may be prone to failure during longer races. The Team therefore informs their Manufacturer or Constructor representative of their concern. The Manufacturer or Constructor agrees that a modification or redesign is appropriate and submits a written proposal with supporting documentation to the Homologating Authority for review. Upon approval the Homologation documents are updated and distributed for equitable customer awareness and part implementation.

Homologation Authority for the Class:

Class	Homologating Authority
LMP2	ACO



EXECUTIVE LEADERSHIP MASTHEAD

John Bishop* / Bill France, Sr.*

Founders – IMSA

Dr. Don Panoz*

Legacy Vice Chairman

Jim France

Chairman

Lesa Kennedy

Director

Ed Bennett

Chief Executive Officer

John Doonan

President

Amanda Oliver

Senior Vice President & Legal Counsel

David Pettit

Senior Vice President, Marketing

Simon Hodgson

Vice President, Competition

Brandon Huddleston

**Vice President, Partnership Marketing and
Business Development**

***Deceased**

ARTICLE 1. DEFINITIONS SPECIFIC TO THE TECHNICAL REGULATIONS

- 1.1.1. **Car** means a singular representation of a Car Model entered by an Entrant in an Event.
- 1.1.2. **Car Model** means a specific model of a vehicle constructed by an IMSA-recognized Manufacturer Partner, and intended for Competition.
- 1.1.3. **Class** means a category for Cars sharing a common set of Homologation Regulations and differentiated from others by type of Car Model.
- 1.1.4. **Competition** means a contest of competitive nature in which a Car takes part during an Event and results of which Competition are published.
- 1.1.5. **Constructor** means an entity that designs and builds race car chassis.
- 1.1.6. **Entrant** means an entity or person who has entered a Car that has been accepted for Competition and holds an IMSA Membership in the capacity of an Entrant or Entrant/Driver.
- 1.1.7. **Event** means an IMSA Sanctioned motorsport activity. It includes the designated Race as well as all periods for registration, inspections, practice Sessions, qualifying Sessions, racing, pre- and post-Race activities and inspections, and rain or postponed dates related thereto.
- 1.1.8. **Homologate** means to execute the Homologation Process.
- 1.1.9. **Homologated** means a Car Model approved through the Homologation Process.
- 1.1.10. **Homologation** means the concept of all things associated with Homologation Authority approval via the Homologation Process.
- 1.1.11. **Homologation Authority** means an entity with the authority to Homologate.
- 1.1.12. **Homologation Documentation** means all files, documents, information, and communication associated with the issuance of official approval of Homologation.
- 1.1.13. **Homologation Identifier** means the unique identifier (generally including a string of characters identifying the Category or Class of Homologation followed by a sequential number assigned to the Car Model) serving as a reference to the official approval of Homologation, assigned by the Homologation Authority.
- 1.1.14. **Homologation Process** means all procedures associated with petitioning a Homologation Authority for approval that a Car Model complies with the Homologation Regulations.
- 1.1.15. **Homologation Regulations** means a set of technical requirements and criteria used to design, construct, and document a Car Model intended for racing in a specific category or class of racing.
- 1.1.16. **Manufacturer** means a Manufacturer Partner constructing an approved Car Model.
- 1.1.17. **Manufacturer Partner** means a recognized IMSA Official Automotive Partner.
- 1.1.18. **Specification** means all technical characteristics of the Car Model defined by the Homologation and Technical Catalog.
- 1.1.19. **Specific Homologation** means the Homologation specific to a particular Car Model.
- 1.1.20. **Technical Catalog** means IMSA's collection of data and documents supporting a Car Model
- 1.1.21. **Technically Eligible** means conforms to all technical requirements and criteria defined by these Technical Regulations.

ARTICLE 2. TECHNICAL PHILOSOPHY

2.1. Technical Eligibility

- 2.1.1. Cars representing a Car Model must always respect the Specification.
- 2.1.2. To be eligible for participation in this Class, a Car Model must:
 - a. Be a Car Model constructed by an IMSA-recognized Manufacturer Partner.
 - b. Hold a valid Homologation, approved and issued by an IMSA-recognized Homologation Authority.
- 2.1.3. IMSA is the sole authority to define the Technical Eligibility of a Car Model and issue the Technical Credential.

2.2. Changes

- 2.2.1. Changes to the Specification are prohibited, unless explicitly authorized by IMSA.
- 2.2.2. Manufacturers alone are permitted to petition IMSA to change the Specification; requests by Entrants are not recognized.

2.3. Conflict Resolution

- 2.3.1. These IMSA Technical Regulations shall govern in any case where a conflict exists with the Homologation Regulations and Documentation.

2.4. Final Authority

- 2.4.1. IMSA is the Final Authority with respect to these Technical Regulations.

2.5. Conditions for Use of a Specific Homologation

- 2.5.1. At all times during IMSA-sanctioned Events it is the Entrant's responsibility to ensure the configuration of the Car Model represents the Homologation components of the Specification; including:
 - a. As-Homologated Configuration
 - b. As-Delivered Configuration
 - c. Parts Manual
 - d. Homologation Extension Form Configuration
- 2.5.2. The original, As-Homologated Configuration of the Car Model must not be modified unless permitted by these Technical Regulations.
- 2.5.3. The As-Delivered Configuration of a Car must respect the as-received configuration from the Car Model Manufacturer, unless permitted by these Technical Regulations.
- 2.5.4. The Parts Manual is the official parts catalogue for the Car Model as defined by the Car Model Manufacturer or Constructor:
 - a. Specific parts listed in the Parts Manual must be used on all representations of a Car Model unless permitted by these Technical Regulations.
- 2.5.5. To be eligible for use in any IMSA-sanctioned Event, modifications detailed in Homologation Extension Forms must:
 - a. Be approved by, or have initiated the process to obtain approval from, the Homologation Authority, and appended to the Car Model Homologation.
 - b. Be approved by IMSA
 - c. Be available to all Entrants of the relevant Homologated Car for the next Event.

ARTICLE 3. TECHNICAL TESTING AND VERIFICATION

3.1. Reference Components

- 3.1.1. IMSA may request Manufacturers submit reference components, tooling, and/or templates to the IMSA Technical Department.
 - a. IMSA may retain these components without compensation.
 - b. Manufacturers are responsible for all costs as related to submitting reference components.
 - c. Fees may apply.

3.2. Technical Testing

- 3.2.1. Testing conducted by IMSA may be performed including, but not limited to:
 - a. Restrictor Flow
 - b. Engine Dyno
 - c. Wind Tunnel
 - d. On-track Testing
 - e. Fuel Delivery Testing
 - f. Fuel Consumption Testing
- 3.2.2. Testing and associated costs are the responsibility of the applicable Manufacturer or Constructor.

ARTICLE 4. BALANCE OF PERFORMANCE

4.1. Balance of Performance

- 4.1.1. IMSA may, at its discretion, utilize an adjustment method to maintain competitive equivalency between Cars within each Class, and between Classes.
 - a. Details of the Balance of Performance Process are described in Attachment 2 of the applicable Sporting Regulations.
- 4.1.2. Technical Bulletins are an extension of these Regulations and part of the Rules.
- 4.1.3. Providing false or intentionally misleading information is a breach of these Technical Regulations

ARTICLE 5. SAFETY

5.1. Driver Safety Harness System

- 5.1.1. As Homologated
- 5.1.2. Cars must be equipped with a minimum 6-point Driver safety harness with a valid label demonstrating compliance with one of the following standards:
 - a. FIA Standard 8853-2016: Safety Harnesses
 - i. [FIA Technical List #57](#): Harnesses Homologated according to the FIA Standard 8853-2016
- 5.1.3. Installation must be performed in accordance with instructions provided by the system supplier and/or manufacturer.
 - a. Belt components must be installed at each Homologated anchor point to prevent accidental release or opening.
 - b. Individual belt straps must be independent; any method or attempt to combine individual straps is prohibited.
 - c. Elastic retention straps are prohibited on shoulder belts.
- 5.1.4. Harnesses must be replaced at the request of IMSA, or whenever the following conditions occur:
 - a. Expiration:
 - i. FIA Homologated: Immediately following December 31st of the year printed on the label.
 - b. Damage:
 - i. Following a severe collision.
 - ii. Webbing is cut or frayed, or weakened due to actions of chemicals or sunlight.
 - iii. Buckles are bent, deformed, rusted, or improperly functioning.
- 5.1.5. Entrants are responsible for ensuring the Driver safety harnesses and all associated components are properly labeled, installed, used, and maintained.
- 5.1.6. Belt components must be used as designed by the manufacturer. It is prohibited to mix belt components between manufacturers or certifications.

5.2. Seat

- 5.2.1. As homologated.

5.3. Driver Containment Nets

- 5.3.1. Not Applicable

5.4. Protective Padding

- 5.4.1. Not Applicable

5.5. Master Electrical Switches

- 5.5.1. As homologated.
- 5.5.2. Systems must remain functional during any on track activity or at the request of IMSA.



- 5.5.3. Interior and exterior master switches must be clearly identified by a self-reflective symbol of a red spark surrounded by a white-edged, blue triangle with a base greater than 30 mm.

5.6. Fire Suppression System

- 5.6.1. As Homologated
- 5.6.2. Identification
 - a. Exterior activation mechanism must be marked with a self-reflective symbol with a red edge surrounding a red "E" inside a white circle at least 100 mm in diameter.
 - b. The interior fire activation switch, located in cockpit, must be marked with an appropriately sized decal of a red "E" inside a white circle.
- 5.6.3. Inspection
 - a. IMSA may require removal of the fire bottle for Technical Inspection.
 - b. Entrant is responsible to demonstrate proper system function of the interior and exterior fire suppression activation mechanisms, using the "test" mode if present.

ARTICLE 6. DEFINITION OF CLASS

6.1. Le Mans Prototype 2 (LMP2)

- 6.1.1. Class Structure: Prototype Cars compete in the LMP2 Class of the IMSA WeatherTech Sportscar Championship (IWSC).
- 6.1.2. Eligibility Requirements: To be eligible for participation in the Class, a Car Model must respect the Specification defined by the Homologation and Technical Eligibility requirements:
 - a. Homologation (LMP2):

Homologation Authority:	Federation Internationale de l'Automobile (FIA)
Homologation Specification:	Le Mans Prototype 2 (LMP2) 2021
LM P2 Homologation Regulations:	2023 FIA Technical Regulations for LM P2 Prototype

ARTICLE 7. VEHICLE SYSTEMS

7.1. General

- 7.1.1. All Vehicle Systems and associated sub-systems are listed in this Article.
 - a. Where change to the Homologated Vehicle Systems is permitted, regulatory text is **bold and underlined**.
 - b. Where change to the Homologated Vehicle Systems is prohibited, regulatory text is **light grey**.
 - c. Advisory statements are in normal text.

7.2. Modifications to the Specification

- 7.2.1. Entrants are permitted to execute the following changes to parameters defined by the Homologation component of the Car Model Specification, provided these Technical Regulations, all current Technical Bulletins, and the Technical Credential are fully respected:
 - a. Adjust component settings defined as adjustable.
 - b. Replace components with parts defined as optional.
- 7.2.2. Manufacturers must make any declarations listed in these Technical Regulations in the Technical Eligibility Form.
- 7.2.3. Further authorization to modify the Specification and/or As-Delivered Condition is granted via the following formal communication methods:
 - a. Published IMSA Technical Bulletin
 - b. IMSA Technical Committee Bulletin
- 7.2.4. Informal and/or verbal communication is not considered valid authorization.

7.3. Servicing, Repair, and Replacement

- 7.3.1. All servicing or repair must be made in good faith to restore the Car and all components to their originally intended form and function as defined by the Specification.
- 7.3.2. Entrants are permitted to replace damaged or worn components provided these Technical Regulations are respected.

7.4. Dimensions

7.4.1. General

- a. IMSA's calibrated measurement instruments are the official measurement instruments.
- b. Scrutineering measurement(s) are taken with the applicable dry-type tire set installed.
 - i. Tire compound per the applicable Event SR.
- c. Tire pressure shall be set at 30.0 psi (± 0.5 psi) for scrutineering measurement(s).

7.4.2. Reference Surface

- a. The flat floor reference surface of the Car is measured to the plane of the Technical Inspection surface plate.

7.4.3. Mass

- a. The minimum mass for all Car Models is defined via Balance of Performance Tables and associated Technical Bulletins.
- b. Car mass is measured as-raced minus Driver and Fuel using the IMSA scales during Technical Inspection.

7.4.4. Ballast

- a. **Entrants are permitted to add or remove ballast to achieve minimum mass:**
 - i. Ballast must be located per the Constructor's Base Homologation.
- b. Manufacturers and/or Constructors must place ballast in assigned locations when required by IMSA.

7.4.5. Ground Clearance

7.4.6. Overall Dimensions

- a. Length
- b. Width
- c. Height
- d. Wheelbase
- e. Track
- f. Overhang
- g. Width

7.5. Chassis

7.5.1. General

- a. **Entrants are permitted to execute minimum modifications for the installation of components.**
 - i. All modifications must be approved by IMSA.

7.6. Driver Interface

7.6.1. General

- a. **Entrants are permitted to install a driver hydration system.**
 - i. Installations must be approved by IMSA.
 - ii. System must not serve any additional purpose.

7.6.2. Steering Wheel

- a. **Entrants are permitted to add, and/or modify the shape of, steering wheel grips.**

7.6.3. Pedal Box

- a. **Entrants are permitted to apply non-slip adhesives to the surface of driver pedals.**

7.6.4. Shifting Mechanism

7.6.5. Driver Adjustable Components

7.6.6. Driver Cooling Systems

7.7. Bodywork

7.7.1. General

- a. All bodywork must comply to the submitted homologated CAD and geometries tested at IMSA's Windshear Test, within a tolerance of +/- 2 mm.
- b. No material is permitted to be added or removed from planks.
- c. No bodywork is permitted below the Reference Surface.
- d. **The following films are permitted to be added to the front windscreen:**
 - i. Tear-offs
 - ii. Anti-fog

7.7.2. Bodywork Seams

- a. **Entrants are permitted to apply tape or vinyl ~~ex~~ around refueling receptacle seams and/or rear wing end fence adjustment holes.**

7.7.3. Decals

- a. **Entrants are permitted to apply removable die cut sponsorship decals with the approval of IMSA.**
- b. Windows must remain free of decals and/or tint unless required by IMSA

7.8. Aerodynamic Elements

7.8.1. General

- a. All aerodynamic elements must comply to the submitted homologated CAD and geometries tested at IMSA's Windshear Test, within a tolerance of +/- 2 mm.
- b. No aerodynamic element is permitted below the Reference Surface.

7.8.2. Splitter

- a. As per Technical Bulletin.
- b. The lowest points on the splitter must be coplanar with the Reference Surface within a tolerance of +2 mm / -0 mm.

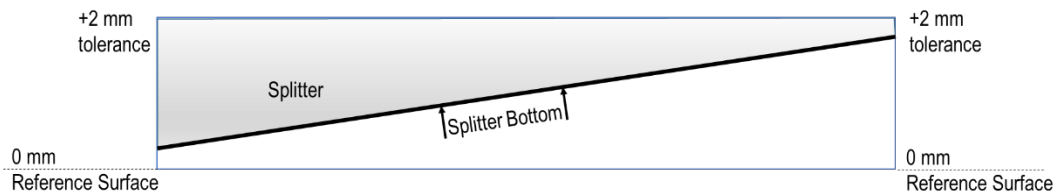

7.8.3. Dive Planes

- a. As per Technical Bulletin.

7.8.4. Body Gurney

- a. As per Technical Bulletin.

7.8.5. Wings

- a. As per Technical Bulletin

7.8.6. Rear Wing Gurney

- a. As per Technical Bulletin

7.8.7. Floor



7.8.8. Friction Blocks

7.8.9. Diffuser

7.9. Engine System

7.9.1. General

- a. Manufacturer seals must be respected

7.9.2. Engine

7.9.3. Oiling System

- a. Approved lubricants are permitted to be utilized.

7.9.4. Lambda

7.9.5. Engine RPM

- a. The maximum engine RPM limits for all Car Models are defined via Balance of Performance Tables and associated Technical Bulletins.
- b. The RPM limit is considered exceeded when either of these conditions occur:
 - i. Engine RPM exceeds RPM limit for more than 250 ms, and actual pedal position is greater than 60% of the maximum
 - ii. Engine RPM is more than 1.0% over RPM limit for more than 100 ms, and actual pedal position is greater than 60% of the maximum, i.e. an 8000 RPM limit is exceeded when RPM is greater than 8080 for more than 100 ms while actual pedal position is greater than 60%.

7.9.6. Intake

7.9.7. Exhaust

7.9.8. Turbo

7.9.9. Engine Control Unit (ECU)

7.9.10. Engine Transportation Crate

7.10. Boost Management

7.10.1. Maximum Boost Pressure

7.10.2. Boost Pressure Ratio

7.10.3. Boost Control Strategy Inputs

7.10.4. Calculation Method

7.10.5. Low Overboost Counter Usage Limitation

7.11. Drive System

7.11.1. General

- a. Manufacturer seals must be respected

7.11.2. Fluids & Lubricants

- a. **Unrestricted.**

7.11.3. Clutch

7.11.4. Gearbox

7.11.5. Gears

7.11.6. Gearbox Control Unit

7.11.7. Differential

7.11.8. Axles

7.11.9. Uprights

7.12. Cooling System

7.12.1. General

7.12.2. Fluids

a. Entrants are permitted to utilize the following approved cooling fluids:

- i. Water
- ii. Air
- iii. Non-glycol based fluids

7.12.3. Inlet Blockers

a. Entrants are permitted to utilize the following approved methods for the sole purpose of blocking off portions of the cooling system inlet openings:

- i. Opaque adhesive tape.
- ii. Panels made from carbon fiber and/or aluminum with associated fastener hardware.

7.12.4. Water System

7.12.5. Oil Cooling System

7.13. Fuel System

7.13.1. General

a. Maximum Capacity

- i. The maximum fuel capacity for all Car Models is defined via Balance of Performance Tables and associated Technical Bulletins.
- ii. The maximum fuel capacity is the total volume of fuel contained in the Car.

7.13.2. Fuel Types

- a. The approved fuel for the Class is IMSA E20C, as supplied by VP Fuels.
 - i. IMSA may require a fuel sample for inspection via a gas chromatograph

7.13.3. Fuel Cell

a. Entrants must use blocks or balls to achieve maximum fuel cell capacity:

- i. Any device, system, or procedure designed to increase, even temporarily, the total fuel storage capacity beyond the maximum is prohibited.
- b. Any configuration of the homologated design intended to decrease the minimum refueling time below the minimum time listed in the class specific BoP table is prohibited.

7.13.4. Fuel Lines

7.13.5. Fuel Sample Port

7.13.6. Refueling Receptacle

7.14. Brake System

7.14.1. General

7.14.2. Fluids & Lubricants

a. Unrestricted.

7.14.3. Bias Assembly

7.14.4. Master Cylinders

7.14.5. Brake Lines

7.14.6. Calipers

7.14.7. Rotors

7.14.8. Pads

7.14.9. Ducting

7.14.10. Brake Duct Inlet Blockers

- a. **Entrants are permitted to utilize the following approved methods for the sole purpose of blocking off portions of the brake duct inlet openings:**
 - i. Opaque adhesive tape.
 - ii. Panels made from carbon fiber and/or aluminum with associated fastener hardware.
- b. Must be fixed.

7.14.11. Anti-Lock Braking System

7.15. Steering System

7.15.1. General

7.15.2. Fluids & Lubricants

- a. **Unrestricted.**

7.16. Suspension System

7.16.1. General

7.16.2. Geometry Elements

7.16.3. Springs

- a. **Entrants are permitted to change primary spring rates:**
 - i. The As-delivered number of springs per wheel must be respected.
- b. **Entrants are permitted to install thrust bearings between the spring and perch.**
 - i. Maximum of two (2) per spring.

7.16.4. Dampers

- a. **Entrants are permitted to change the damper internal build:**
 - i. Inerter technology is prohibited.

7.16.5. Bump Rubbers and Packers

- a. **Unrestricted.**

7.16.6. Anti-Roll Bar

7.16.7. Third Elements

- a. **Entrants are permitted to change third element spring rates:**
 - i. The As-delivered number of springs must be respected.

7.17. Wheels & Tires

7.17.1. General

7.17.2. Wheels

7.17.3. Wheel Attachment

7.17.4. Tires

- a. The approved tire supplier for this Class is Michelin.
- b. Tires must be used in accordance with SSR Attachment 3.



7.18. Electronics

7.18.1. General

7.18.2. Data Logger

- a. IMSA reserves the right to download and/or view all logged data at any time.

7.18.3. Telemetry

- a. **Entrants are permitted to utilize one-way, car-to-pit, telemetry systems for data acquisition purposes.**
 - i. Video and voice transmission are not considered as “data acquisition purposes”

7.18.4. Wiring Loom

7.18.5. Sensors

7.18.6. Radio

- a. **Entrants are permitted to install one (1) primary, and one (1) secondary, two-way voice communication radio with car-to-pit communication capability:**
 - i. Radio(s) must comply with Series Sporting Regulations.
 - ii. Secondary radio must not transmit or receive signals while primary radio is functional.

7.18.7. Rear View Camera

ARTICLE 8. SERIES REQUIRED ELECTRONICS

8.1. General

- 8.1.1. All Series required electronics must be installed per the applicable Homologation and/or Declaration.
- 8.1.2. Entrant is responsible for the operation, maintenance, and care of Series required electronics.

8.2. Series Scrutineering Data System

- 8.2.1. Cars may be equipped with the IMSA Scrutineering Data System at all Events.
 - a. The manual for the Scrutineering Data System for the Class is the Bosch Scrutineering Systems Manual (BSSM)

8.3. Marshalling Display System

- 8.3.1. Cars must be equipped with an approved Marshalling Display to indicate active flag status.
 - a. XAP NTX Marshalling Display

XAP NTX Marshalling Display	Creative Motorsports Solutions
MSE Antenna Kit	
MSE Safety Light Receiver	
ORECA Cockpit Loom	
Ligier Cockpit Loom (TBD)	

- 8.3.2. The Marshalling Display system must be installed and functioning during on-track activity.
 - a. The supplied antenna must be mounted per the Car Model's Scrutineering Homologation.

8.4. Driver ID System

- 8.4.1. Cars must be equipped with an approved Driver ID system.
 - a. XAP NTX Marshalling Display
 - i. Available for purchase from Creative Motorsports Solutions.

- 8.4.2. Minimum loom/harness ordering window is 8 weeks. Expedited fees may apply if ordering window is not respected.
- 8.4.3. Entrant must supply Driver ID Plugs.
- 8.4.4. Female Driver ID plug(s), (i.e. Driver #1 through Driver #5) may be installed inside the Car cockpit or attached to the individual Drivers' helmets.
 - a. Alternative installations must be approved by IMSA.
- 8.4.5. Transponder and plugs must operate to the satisfaction of the Timing and Scoring Officials.

8.5. X2 Transponder System

- 8.5.1. Cars must be equipped with the X2 Transponder System Kit.
 - a. X2 Transponder Kit contains the following component(s):
 - i. Transponder.
 - ii. Isolation Mounts.
- 8.5.2. X2 transponder must be purchased via the IMSA Accessories Order Form.
- 8.5.3. X2 transponder must be installed in the same location as the applicable Constructor has determined in the Scrutineering Homologation Document.
- 8.5.4. X2 Transponder must be mounted using the mounting bracket with appropriate thermal protection in an area where the temperature cannot exceed 50 °C

8.6. Leader Light System

- 8.6.1. Cars must be equipped with LED leader light panel system as follows.
 - a. XAP
 - i. XAP Leader Light System # LPP-130
 - ii. Available from CMS (<https://www.gomuchfaster.com/products/imsa-xap-led-position-panel>)
- 8.6.2. Leader light system must be installed and functioning during the Event
 - a. System must be installed in accordance the Manufacturer submitted, IMSA Approved, Series Electronics Declaration Form
 - b. Series Electronics Declaration Form is available from the respective Manufacturer Partner.
- 8.6.3. Leader Lights consume less than 4.5 A (10-15 VDC), and must:
 - i. Be a fused, 12-volt DC configuration
 - ii. Meet the specifications defined by ISO 7637
- 8.6.4. Minimum loom/harness ordering window is 8 weeks. Expedited fees may apply if ordering window is not respected.
- 8.6.5. Leader light system must be installed and functioning during Events

8.7. Back-lit Panel

- 8.7.1. Cars must be equipped with white light-emitting side number panels for Races taking place partly by night.
 - a. Colored background must be cut out in the number shapes so they are illuminated during the night.
 - b. White light-emitting side number panels are supplied by Entrants.

8.8. Pro-Am Light

- 8.8.1. Cars must be equipped with a Pro-Am light per the Car Model's Scrutineering Homologation document.
- 8.8.2. Pro Am light must be powered on at all times when the car is participating in on-track activity.

8.9. Rain Light

- 8.9.1. Cars must be equipped with a Rain Light system controlled by the Entrant.
 - i. Entrants are required to turn the system on or off, change the brightness, and/or flashing frequency of the Rain Lights upon request from IMSA.

8.10. In-Car Camera

Not Applicable

8.11. Incident Data Recorder

- 8.11.1. Entrants must utilize the FIA Impact Data Recorder (IDR)
 - a. Must be installed per the Car Model's Scrutineering Homologation.
 - b. IDR must be installed and functional for all on-track activity.
 - c. IMSA provides the IDR to the Entrant.
 - d. Data collected by the IDR is property of IMSA.
 - e. IDR must be surrendered upon request by IMSA.

ARTICLE 9. REFUELING SYSTEM

9.1. Fuel Transfer

- 9.1.1. Fuel must be transferred from the autonomous supply tank to the Car using the equipment and methods defined in this Article.
 - a. Approved equipment as defined herein must be:
 - i. Unmodified.
 - ii. Installed and operational.
 - b. Approved method:
 - i. Gravity.
- 9.1.2. Fuel transferred to the autonomous supply tank must be delivered by means of a hose fitted with a self-sealing connector (e.g. dry break, cam-lock) connected to the autonomous supply tank.

9.2. Pit Tank

- 9.2.1. Construction of the Autonomous Supply Tank must:
 - a. Comply with FIA Appendix J Article 257A Drawing n° 252-7 with the exception of the top plate shape and dimensions.
 - b. Not have sensors other than as required by IMSA.
- 9.2.2. Pit tanks are assigned a serial number by IMSA Technical Officials.
 - a. IMSA Technical Officials will apply a non-removable official technical inspection serial number label to pit tanks
 - b. The maximum permitted refueling tank height is 2.2 meters as measured from the top surface of the vessel (not including vent, cover plate or fasteners) at a distance of 1.25 meters from the outermost face of the pit wall.

9.3. Peripheral Connections

- 9.3.1. Tanks must be equipped with the IMSA-specified peripheral connections between the tank outlet and the refueling hose.
 - a. Parts must be purchased from RPXpress (Phone: +1-828-428-0820 Email: Imcelwain@rpxpress.com) and used unmodified:

Part Number	Part	Description
ATL-TF 147	12-Bolt Gasket	2 Needed (Outlet and Vent Flanges)
BSR.FR.1981.1	Bottom Elbow 67.12°	Female Camlock x Male 2" (Red)
BSR-FR R003	Deadman Valve	Stainless Deadman Valve
BSR.P.5K56.SS	Restrictor Housing	Deadman Outlet, 2" Male to 1 ½" Camlock
BSR.P.5K.RPX.SS	Hose Coupler	Connects 1.5" I.D. hose to Restrictor Housing
BSR.FR.DD	Discriminator	Rollover safety valve
BSR.FR.FN39	Vent mounting flange	Top surface mounting flange

- b. Alternate discriminator valve(s) and associated mounting flange(s) may be permitted by IMSA Officials.
- c. Sensor must be oriented such that the face plate is directed toward the hot pit lane.
- d. FIA nut ring, as-supplied with original tank, must be used to secure the restrictor housing to the bottom of the supply tank.
- e. Refueling System Assembly Illustration:

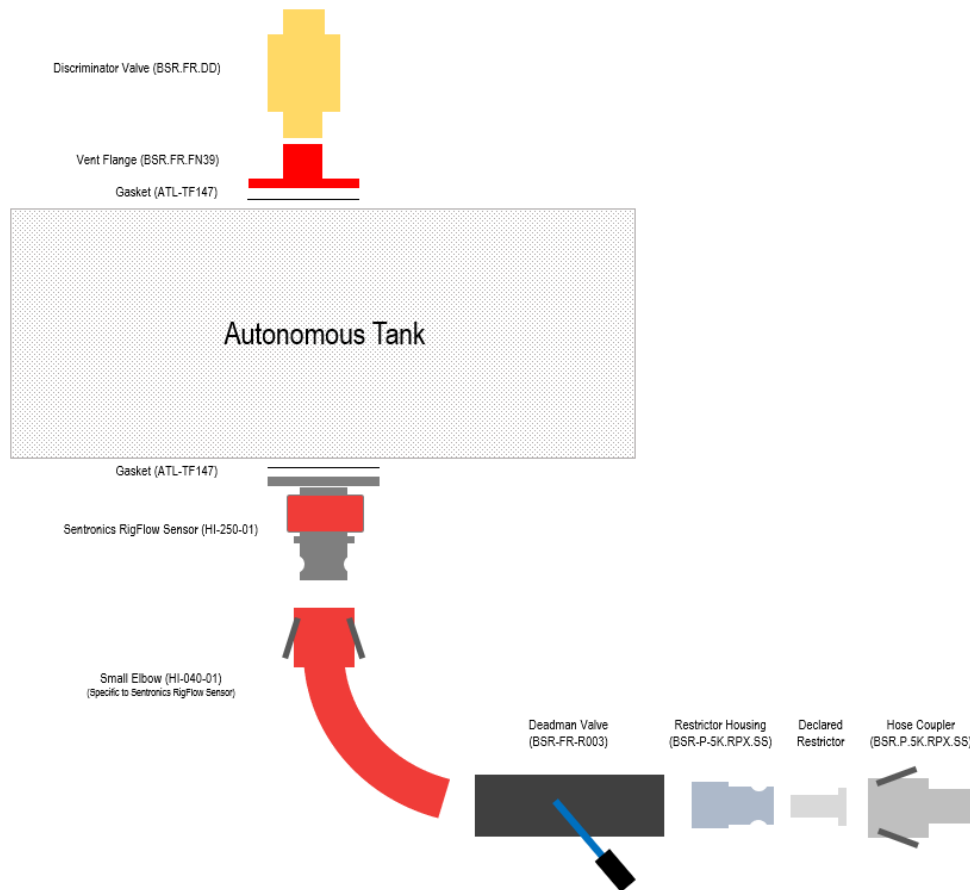

- 9.3.2. Details and purchasing of the of the Sentronics RigFlow Sensor can be found in Article 11.8
 - a. Sensor must be oriented such that the face plate is directed toward the hot pit lane.
- 9.3.3. Deadman valve and bottom 80 deg. elbow assembly must be securely braced to remain attached to the tank in the event of an incident.
 - a. Mechanisms preventing normal operation of the deadman valve are prohibited.
 - b. Any configuration of the IMSA-mandated design intended to decrease the minimum refueling time below the minimum time listed in the class specific BoP table is prohibited.
- 9.3.4. During refueling the air vent outlet must be connected using an appropriate coupling to the tank.
 - a. In dual point refueling, the dedicated vent hose maximum inside diameter must be less than 1.5 inches.
- 9.3.5. A sight glass is permitted to be installed to the outside of the supply tank and must be equipped with isolating valves mounted as close as possible to the tank.
- 9.3.6. Vent tube may be shaped to avoid interference with overhead obstruction(s), the minimum functional vent height of 1 m must be respected per FIA Appendix J Article 257A Drawing n° 252-7.
- 9.3.7. A foam-based spark arrester must be installed in the vent head and remain visible from the pit lane surface.

9.4. Refueling/Vent Hoses

- 9.4.1. Refueling/vent hoses must have one end equipped with a self-sealing connector to fit the autonomous supply tank outlet.

- 9.4.2. Refueling/vent hoses are permitted to be protected for the sole purpose of resisting abrasion damage.
 - a. Cover must be easily removable by means of full-length Velcro or zipper.
- 9.4.3. Hose maximum inside diameter:
 - a. Dual-port systems must be less than 1.5 inches for all hoses.
 - b. Single-port (coaxial) systems must be less than 1.5 inches for Refueling Hose and less than 75.0mm for Vent Hose.

9.5. Autonomous Tank Support Stand

- 9.5.1. The tank must be attached to one of the following:
 - a. Through a tower, to a trolley meeting the following requirements:
 - i. Have a surface area greater than two (2) square meters.
 - ii. Utilize four (4) self-braking casters.
 - iii. Be ballasted with weight exceeding that of the tank when filled with fuel.
 - b. Scissor style (X-brace) stand
- 9.5.2. Trolley is permitted to have load sensors for the sole purpose of weighing fuel in the Autonomous Tank.
- 9.5.3. Tank Support Stand must have a minimum of two (2) support feet directly on paved surface without the use of shims.
 - a. One shim is permitted to be added to each of two (2) support feet.
- 9.5.4. Tank Support Stand feet must be a minimum of 200 mm wider than the diameter of the Autonomous Tank.
- 9.5.5. Tank Support Stand setup and leveling assembly(s) must be to the satisfaction of IMSA Officials.

9.6. Boom

- 9.6.1. Entrants are permitted to attach a member (boom) to the trolley.
 - a. Boom must be independent of the tank and the tower.
 - i. Boom member must be permitted a degree of freedom in relation to the trolley (rotation following a vertical axis).
 - b. Boom are permitted to support:
 - i. Hose for a Car utilizing an approved offset vent or fuel filler.
 - ii. Lighting for the illumination of the pit stop.
 - iii. Download cable.
- 9.6.2. Boom must be identified with the Car number fixed to its outboard end, that must be:
 - a. Visible from either direction
 - b. A minimum of seven (7) inches high with a 1.25-inch stroke
- 9.6.3. Boom must respect the following dimensions:
 - a. Must not exceed four (4) meters in length
 - b. Must permit free passage of a height of two (2) meters over its entire length including hoses and/or accessories.

9.7. Refueling Restrictor

- 9.7.1. During refueling, all fuel entering the Car must pass through the refueling restrictor.
- 9.7.2. Refueling Restrictor must meet the following criteria:
 - a. Material must be an aluminum alloy.
 - b. Must comply with the IMSA Fuel Restrictor Part Drawing at the end of these Technical Regulations.
 - c. Restrictor size varies from 22.0 mm to 35.0 mm by discrete increments 0.25 mm
 - d. Bore tolerance (+0.00 mm / -0.05 mm)
- 9.7.3. Refueling restrictors may be purchased from RPXpress (Phone: +1-828-428-0820 Email: lmcelwain@rpxpress.com).

9.7.4. IMSA utilizes the following scrutineering inspection methods to check minimum refueling times:

- a. Calibrated autonomous tank sensor system.
- b. Calibrated vehicle fuel flow sensors.

9.8. Autonomous Tank Sensor System

9.8.1. Autonomous fuel supply tanks must be equipped with a Sentronics RigFlow autonomous tank fuel flow meter and wiring loom.

- a. Flow sensor part number (HI-250-01).
- b. Wiring harness part number ([CMS2021-1487](#)).
- c. The fuel flow sensor kit and wiring loom must be purchased from an authorized Sentronics dealer
 - i. Sensors packages are serialized, and assigned to a Car and Pit Tank.
- d. Sensors packages must remain exclusive to the assigned Car and Pit Tank throughout the Event in which the sensor is declared.

9.8.2. Entrant must ensure the flow sensor system is functional.

- a. Two hours before 1st Practice Entrant must connect the loom to a specific pit-lane network box designated by IMSA.
- b. Loom must remain connected until the conclusion of the Event
- c. Entrant must remove the loom at the conclusion of the Event.
- d. Flow Sensor must be installed in the location and orientation as indicated in Article 9.3.

9.8.3. Wiring loom connects the sensor package to a dedicated port on the IMSA pit-lane network box.

- a. Wiring loom must be IMSA certified and unmodified
- b. Wiring loom installation must remain visible and traceable
- c. Wiring loom part number ([CMS2021-1487](#)) must be connected directly to the flow sensor and directly to the pit-lane network per the drawing below.

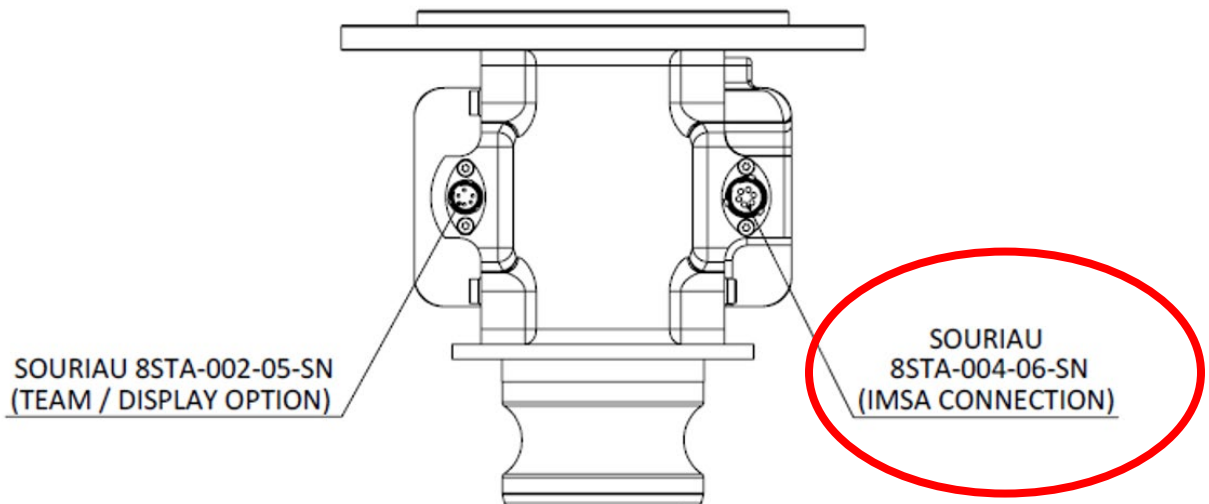

9.8.4. Entrant Data Port Access

- a. Entrant is permitted to access data provided by the RigFlow meter by utilizing approved part(s) from approved vendors as listed below:

Part	Vendor Link
Greaves Rig Flow APMS V3 System (including approved harness)	Greaves
RigFlow Harness (approved harness only)	Creative Motorsports Solutions

- b. Approved harness is permitted to be directly connected to the appropriate port of the RigFlow meter per the drawing below:

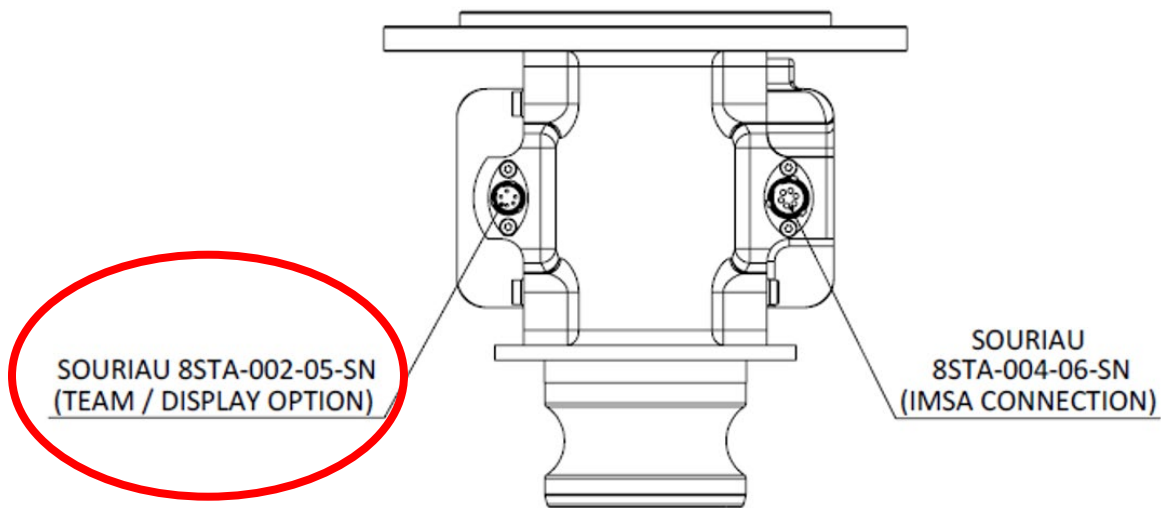

9.9. Scrutineering Fuel Collection

9.9.1. Fuel Collection Vessel must:

- a. Be non-opaque.
- b. Be free of any carriage or trolley system.
- c. Have a flat bottom.
- d. Rest without assistance on the IMSA scale for weight measurement before and after defueling the Car.

9.9.2. Fuel Pump Out Hoses

- a. Entrant must utilize 2 separate hoses for defueling activities:
 - i. Fuel drain
 - ii. Vent return
- b. Both hoses must connect the Car to the collection vessel.
- c. Fuel drain hose must utilize a dry-break connection to the Car and fixed (sealed) connection to the fuel collection vessel.
- d. Fuel vent return hose is permitted to utilize a temporary or dry-break connection to the Car and must use a fixed (sealed) connection to the fuel collection vessel.
- e. Fuel drain hose must have a clear section of no less than 250 mm near the collection vessel.

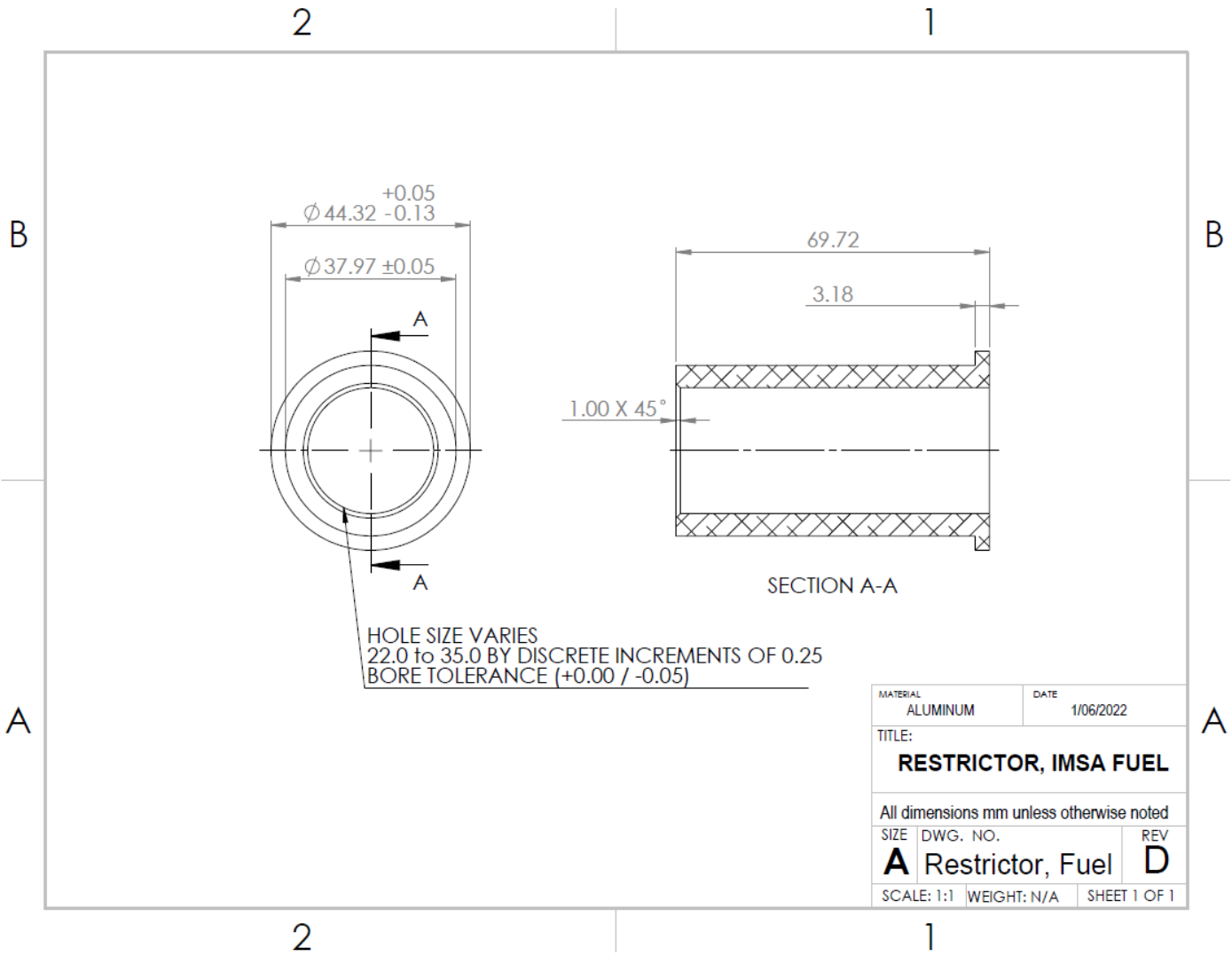

MATERIAL	ALUMINUM	DATE	1/06/2022
TITLE:			
RESTRICTOR, IMSA FUEL			
All dimensions mm unless otherwise noted			
SIZE	DWG. NO.	REV	
A	Restrictor, Fuel	D	
SCALE: 1:1	WEIGHT: N/A	SHEET 1 OF 1	