



HURACAN SUPER TROFEO TECHNICAL REGULATIONS 2024

CARS ADMITTED

1. Lamborghini Huracan Super Trofeo EVO2 or updated vehicle with official "EVO 2 Kit".

GENERAL PRINCIPLES

2. Anything not expressly authorized by these regulations or by the Technical Documentation is prohibited. The official Lamborghini Technical Documentation including Spare Parts Catalogue, Wiring Diagrams, Workshop Manual and Technical Bulletins, has to be considered as reference for what is not specified in the Technical Regulations and on the Technical Form.

The only operations, which may be carried out, are those necessary for routine maintenance or for the replacement of worn parts or those damaged through accident. It is expected that each entrant will dispose of all the equipment in order to perform these operations. The limits to the modifications and to the assemblies allowed are specified in these regulations. Unless provided by these authorizations, any part altered through wear or accident may only be replaced by a part of identical origin to the damaged piece. Additions to parts or materials are forbidden unless expressly authorized by these regulations or by the Form or by the Technical Bulletins, and by the official Technical Documentation.

Competition Cars must always follow the specifications of the components to be used and their correct assembly provided by the following references:

- I. Technical Form and Technical Passport;
- II. Technical Manual;
- III. Spare Parts Catalogue;
- IV. Comparison with series characteristics, latest construction designs and categorically up-to-date as per Technical Bulletins.
- V. Identification by anti-counterfeiting stickers or RFID

The Competitor is responsible for the conformity of the Car and the parts assembled therein, and is therefore obliged to ensure that they are in order before each race.

SPARE PARTS

3. The Competitors are authorized to use only original spare parts provided by Lamborghini. The use of non-official spare parts without the official Lamborghini sign, will result in penalties or disqualification of the competitors.
The Lamborghini Technical Scrutineers are able and allowed to check at any time all the spare parts, and in no case the competitors can refuse from these checks.

MINIMUM WEIGHT

4. Minimum weight:
It is the competitor's responsibility to ensure that at all times during a competition the mandatory minimum weight of the car with empty fuel tank, is reached.
At no time during a competition is the car weight permitted to be less than the mandatory minimum weight when the car is either presented for technical scrutineering, on the track or in Parc Ferme.
The minimum weight must also be observed when the levels of operating liquids are under minimum level.
The official scale is located in the Series technical scrutineering tent or in an alternative designated place.



SQUADRA CORSE

The Lamborghini Huracan Super Trofeo EVO2 cars, including their safety devices and all the lubricants (excluding the fuel), must weight no less than 1250 Kg (excluding the driver).

The minimum weight of the car equipped with muffler exhaust is 1265 kg.

Checking of weights may be carried out:

- a) After the official qualifying session
- b) After the race

The minimum weight of a vehicle consists of:

A. The weight of the car with empty fuel tank; The weight of the inboard camera, the radio system, the driver comfort systems or the weight of the respective substitute ballast.

B. The installed additional weights

It's important to remind that the car must end all the qualifying sessions and the races with at least 3 liters of fuel which is not included into the minimum weight mentioned above.

5. Ballast:

The installation of ballast is permitted. Only original Lamborghini ballast components must be used. These must be installed in the provided fixing points at the position of the passenger's seat.

The ballast weights are identified by spare part numbers:

- 4TA861722 PASSENGER BALLAST FIXING PLATE (12 kg)
- 42A861721AA BALLAST UNIT 2.5kg
- 42A861721AC BALLAST UNIT 3.4Kg
- 42A861721AB BALLAST UNIT 5.2Kg
- 4TA861721 BALLAST UNIT 2KG

Addition or removal of ballast during the race is prohibited.

No weight may be removed from the OE structure of the car and be placed in the ballast box.

If the base plate does not contain the necessary holes for the mounting positions they can be added after consultation with the Technical Scrutineers.

6. Weight changes during qualifying and races:

During any qualifying session and race, the weight of the car is only permitted to be altered by:

- Changing from slick tires to wet tires or vice versa;
- Consumption of consumable materials and fluids.

On the way from the circuit to the Parc Fermé and in the Parc Fermé itself, and on the way to the post-race technical scrutineering under no circumstances is weight permitted to be added or removed to the car.

7. Verification of the minimum weights by the participants on the official scale:

Competitors have the opportunity to check the weight of their cars and drivers during the event on the official scale.

Only the measurements recorded by the Technical Scrutineers shall be deemed accurate for the purposes of compliance with the regulations.

8. Leaving the weighing area :

Without the consent of the Technical Scrutineers, the car is not permitted to be removed.

MINIMUM HEIGHT

9. Minimum Height

No sprung part of the car (chassis, bodywork, mechanical parts, etc.) is permitted lower than the underfloor. (Rear diffuser lateral fins excluded 4TA804851/4TA804852).

At any time, it must be possible to check the static minimum height of the car which shall be not less 75mm, measured at the positions shown below.

In no case shall the vehicle touch the ground when all tires are deflated.



SQUADRA CORSE

Front ride height through the line below:



Rear ride height through the line below (Between rear diffuser external fin LH 4TA804851 and RH 4TA804852):



Heights must be checked with the slick tires adjusted at 1.8 bar (26 PSI).
In case the car closes the session with rain tires, the check of the height will be carry out with slick tires.

This measurement is carried out on the official Lamborghini flat patch.

Checking of height may be carried out:

- a) After the official qualifying session
- b) After the races

Lamborghini will inform the competitor in case of any other modification needed to the heights.



ENGINE

10. General description
 - Aluminum V10 ENGINE rear-mounted LBSC Sealed
 - 5,209 cm³ ; stroke 92.9 mm; bore 84.5 mm
 - Max. rpm: 8,600 rpm
 - Single-mass flywheel
 - Four valves per cylinder
 - Variable cam phasing (Intake & Exhaust)
 - Direct fuel injection
 - Required fuel quality: minimum 98 octane, unleaded
 - Dry-sump lubrication
 - Electronic engine management (MOTEC M190 ECU)
 - Race exhaust system with race catalytic converter or muffler
 - Electronic throttle pedal
 - Entrants may utilize non glycol based fluids. A maximum of 2.0-liter Corrosion Protection Coolant.

The engine must be strictly standard.

For this reason all the engines are sealed directly by Lamborghini on both heads (camshaft driving covers & camshaft covers) and on the bottom side (Oil sump), by anti-counterfeiting sealings or RFID in that way no work can be carried out.

Seals must remain in place. It is forbidden to carry out any work on the engine.

CAUTION : The competitor / team are responsible of the engine seals

Engines can be called in and inspected at the instructions of the Technical Scrutineering team.

Nobody either Entrant, Competitor, Team or Dealer are allowed to carry out any kind of maintenance work on the engine.

Only Lamborghini is allowed to carry out maintenance work on the engine.

In case of failure the engines have to be sent directly to Lamborghini still sealed.

The Competitors are not allowed to compete in the event if the documentation and seals do not conform to the rules.

Lamborghini reserves the right to check the conformity of the seals on the engine at any time.

The retouching of any part of the engine is prohibited; material may not be removed or added unless permitted by these Regulations, Technical Form or Bulletins.

To avoid problems and non-authorized changes or modification to the engine, Lamborghini will collect and collate the engine serial number with the chassis number of each vehicle.

For any maintenance or replacement operation, involving the sealing removal, the competitor will have to compile the proper claim form. (please refer to the specific Bulletin).

WARRANTY: engine used in competition are not covered by any warranty.

Engine must run with the specific air restrictor (2x41mm diameter 4TA129640) that has been recorded by ACI SPORT.

All the air feeding the engine must go through the air restrictors.

The following air intake section must be respected:

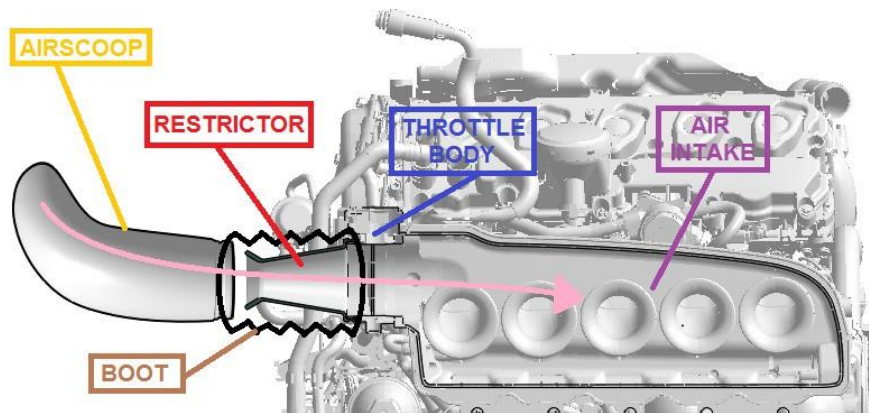

During the official events (race) weekend Lamborghini reserves the right to check the air intake system by "stall test".

ELECTRICAL SYSTEM

11. The socket for connecting diagnosis equipment must always be functioning and accessible at any time for all the ECUs.

Engine electronic control units:

During the weekend of the races Lamborghini, in agreement with the Technical Scrutineers, reserves the right to replace or check at any time the ECU (electronic control unit) dedicated to the engine/gearbox management system or check the conformity of the SW of the ECU.

ECU incl. the complete wiring harness must be used without modifications. The Series Organizer or the Technical Scrutineers reserve(s) the right to check or change the MOTEC ECU or record the engine characteristic data at any time during the event. The Series Organizer reserves the right to reprogram the MOTEC ECU at any time of an event. It is thus ensured that the status of the program and data is identical for all participating cars.

External data logging systems are permitted only if connected to the standard "FIA IC" CAN connector available in the car (i.e. V-box or similar) with own GPS.

The engine management ECU access is forbidden to the teams.

The acquisition table in the data logger must be the original one indicated by Lamborghini.

Only the official customizable functions (i.e. Shift lights, logging time, sensor zeroing) can be modified by the team

It is possible to adopt linear potentiometers on the suspension components, ride height sensors, damper load cells and TPMS only as supplied by the official Lamborghini Spare Parts catalogue.

Installation of a system that allow communications between driver and team crew (i.e. Radio or Mobile Phone) is compulsory.

Headlights, Rear lights and rain lights must be working properly during the entire Event.

Supplementary colored lights for recognizing the cars in the pit lane are allowed only for the night race events and they have to be installed inside the front windshield area.



11.1 Transponder TR2 and X2 Driver ID Unit

Each car must be equipped with the approved timing transponder sold by Official Lamborghini Super Trofeo Spare Parts (4TA919052A + 4TA919052B).

A. Kit contains the following components:

1. Transponder TR2
2. X2 Driver ID Unit
3. Power connection cables
4. Transponder Mounting Bracket

11.2 In Car Camera/Data:

On-board cameras which have been approved by the Series Organizer (Motec V2 Camera) or other brands are permitted to be used.

Camera and mounting must use metal hardware and be mounted in a way to withstand impacts.

Mountings must be approved by Lamborghini Official Technical Delegate.

Teams must only connect to the "REAR CAN" connector for video function and "FIA IC" connector for data recording.

11.3 On-board marshalling systems

In case of Marshalling system installation it must be connected on "FIA IC" plug on passenger side and operating all the time.

Others electrical/electronic systems (PIT TIMERS/ GPS SYSTEM /ONBOARD CAMERA or DATA LOGGER such as VBOX OR SIMILAR) may be used but must be connected only at the power supply. Position and safety fixing of the devices must be checked and approved by the official technical scrutineers and the Lamborghini Squadra Corse technicians.

GEARBOX / TRANSMISSION

12. The gearbox must be the one prescribed by Lamborghini and therefore must be strictly original.

General description:

XTRAC six-speed sequential dog-type gearbox

Sealed by AUTOMOBILI LAMBORGHINI "SQUADRA CORSE"

Gear ratios:

Bevel gear 21/23

Final drive 15/50

1st gear 13/37

2nd gear 15/33

3rd gear 15/27

4th gear 19/28

5th gear 21/26

6th gear 19/20

Mechanical limited slip differential

Electrical gear shift activation (paddle shift)

Differential must be original and also the internal part mounting must be standard.

Ramps angles must be 30° power and 45° brake as indicated in the official technical sheet.

The non respect of the mounting direction of the ramps is a non-conformity.

The number of friction plate and the assembly order shall correspond to the specification in the Technical Manual and must not be changed. The fitted friction plates must comply in terms of part number, allocation and specification (see parts catalogue).

Differential preload torque must be maximum 60 Nm as indicated in the official technical form (pag. 40) measured minimum after 30 minutes the end of the race or qualifying session.

All vehicles must have a reverse gear which can be engaged at any time during the event when



the engine is running and the driver is seated in the vehicle.

In case of repair after a failure or for a standard maintenance if you choose to send the gearbox to Squadra Corse technicians (please refer to the specific Bulletin).

The teams can also do the gearbox/differential repair or maintenance job individually using the original Lamborghini components as listed in the Spare Parts catalogue.

Lamborghini reserves the right to check the conformity of the gearbox and differential at any time.

The retouching of any part of the gearbox/differential is prohibited; material may not be removed or added unless permitted by these Regulations, Technical Form or Bulletins.

To avoid problems and non-authorized changes or modification to the gearbox, Lamborghini will collect and collate the gearbox serial number with the chassis number of each vehicle.

WARRANTY: gearbox used in competition are not covered by any warranty

WHEELS / TYRES

13. Only the supplied and available on track tires, slicks or rain, in the following sizes are allowed:

Front slick: 300/660-18 L54 or C54H
Rear slick: 300/680-18 L54 or C54H

Front rain: 300/660-18 W52/ W52H
Rear rain: 300/680-18 W52/ W52H

The official technical scrutineers and the tire supplier technicians are allowed to control at any time that tire pressures are in compliance with the official TYRE SUPPLIER requirements.

Any chemical, mechanical or thermal treatment of the tires is prohibited. Cleaning of the rims is permitted. The mechanical removal of rubber abrasion and stones is permitted. The use of heated covers, materials or other means that change the temperature of the tires is prohibited for the entire duration of an event. From the time of the pre-start until the end of the session for the event approved tires are not allowed to be covered. This applies for slick as well as rain tires.

It is not permissible to rotate the tyres on the rims.

The tyre manufacturer prescribe a mounting procedure for its tyres, then any departure from the manufacturer's prescription is prohibited.

Tyre logs

Tyre Allocation to teams will be managed by Hankook Motorsports USA and provided to IMSA and Lamborghini upon request. All tires will be recorded and checked during official sessions throughout the racing event.

Only the standard aluminum rims supplied by Lamborghini in the following dimensions are allowed:

Front: 11" x 18 ET 28,8mm
Rear: 12" x 18 ET 32mm

It is mandatory to have at least 3 wheel sets for each car for easy mounting tires during the events.

It is allowed to paint the wheels with no dimensional change.

It is prohibited to paint or treat any functional surfaces (rim bed, contact area of wheel nut, mounting surface of the wheel). The friction strips on the inside of the rim must stay functional and must not be treated in any way.

For safety reasons, the valves cap are mandatory.



Lamborghini SQUADRA CORSE and HANKOOK staff is authorized to recall rims and to request the replacement of the valves if considered not suitable and adequate to run.

Under no circumstances the Camber shall exceed the maximum values of:

Front: 0° up to -3,0°
Rear: 0° up to -2,5°

Camber adjusting is permitted within the above limits by adding and removing the official Lamborghini shims (0,3 mm – 0,5 mm – 1 mm) positioned only between chassis and upper suspension arm (on both axles).

No type of spacers are allowed between the frame and the lower suspension arms which would increase the track of the car.

Lamborghini reserves the right to modify these values according to the circuit or TYRE SUPPLIER. This measurement is carried out on the official Lamborghini flat patch.

BRAKE SYSTEM

14. Only the following parts are permitted:

- Front steel brake discs:

- TM EVO8 brake discs, Diameter = 390 mm, 35 mm Thick,
Part number: FL: 4TA615029B
FR: 4TA615030B

- Rear steel brake discs:

- TM brake discs, Diameter = 355 mm x 32mm Thick,
Part number: FL: 4TA698601C
FR: 4TA698302C

- Lamborghini Bosch Motorsport ABS M4 or ABS M5,

- Mono block TM 6 pots front caliper:

- Part number: FL: 4TA615105A
FR: 4TA615106A

- Front caliper spacer (4TA615232)

- Mono block TM 4 pots rear caliper:

- Part number: FL: 4TA615405A
FR: 4TA615406A

- Brake bells (4TA698211A + 4TA698219B) and drive pins (4TA601116 or 4TA698545)

- Front Brake Pads TM (4TA615415A)

- Rear Brake Pads TM (4TA615416A)

- Brake master cylinders by AP Racing (for old spec) and Tilton (for new spec) allowed by user manual and technical sheet,

Brake parts without official Lamborghini codes clearly visible are NOT ACCEPTED at any time.

Only original brake cooling intakes/pipes are allowed and only in the positions specified in the user manual and the technical form.

In the brake pedal system only one of the two different (long/short) brake drop link supplied by Lamborghini must be used (4TA721743 or 4TA798109).

The official technical scrutineers and the Lamborghini Squadra Corse technicians are allowed to control the conformity of the braking system at any time.

WHEEL SUSPENSION

15.

- Forged control arms & top mounts: Stiffness optimized
- Wheel hubs with centre-lock wheel nut
- Shock absorbers with motorsport specific valve characteristic,
- Double-blade-type adjustable anti-roll bars

15.1 General description front axle

- Double wishbone front suspension, adjustable ride height, camber and toe
- Electric power steering with manual function to easy car maneuvering

15.2 General description rear axle

- Double wishbone rear suspension, adjustable ride height, camber and toe
- Motorsport driveshafts optimized for reliability and durability

15.3 Anti-roll bars

Blade Adjustable Front Anti-Roll Bar (4 positions):

- Position 1 is the hardest position. The bar is vertical.

Position 4 is the softest position. The bar is 90 degrees from the vertical. Adjustable rear Anti-Roll Bar (2 positions) + 1 added with the extension (4TA511051):

- Position 1 (extension) is the supersoft.
- Position 2 is the soft.
- Position 3 is the hard.

Anti-roll Bars stiffness can be adjusted only using the official available configurations.

It is also possible to disconnect the anti-roll bars (front and/or rear).

The anti-roll bars are only permitted to be unhooked provided that one coupling rod of the respective rollbar is completely removed.

SHOCK ABSORBERS

16. Only the Super Trofeo original Ohlins TTX-36 (2 way) shock absorbers as described in the Official Technical Form must be used.

The dampers must comply with the Super Trofeo configuration released by Lamborghini concerning the hydraulics and bump stop.

Shock absorbers springs:

Only the factory approved springs are permitted to be used.

It is not possible to remove, add, cut or modify the bump stop that must respect the original shape (8mm thickness):

Front Bump Stop



Rear Bump Stop



Part numbers:

Dampers:

- Front: 4TA412019
- Rear: 4TA512019

Main springs:

- (190 N/mm): 4TA498998C
- (220 N/mm): 4TA498998B
- (250 N/mm): 4TA498998A
- (270 N/mm): 4TA412105
- (290 N/mm): 4TA512159
- (310 N/mm): 4TA498998
- (330 N/mm): 4TA598001

Helper spring:

- Front: 4TA498210B
- Rear: 4TA498210B

The official technical scrutineers and the Lamborghini Squadra Corse technicians are allowed to verify the shock absorbers and / or need to be replaced with other guaranteed by the manufacturer any time during the event.

PIPES/WIRING/HEATING SHIELD AND PROTECTIONS

17. The arrangement of all the components must remain as per the original layout and/or as per official Technical Bulletin from Lamborghini.

Ohlins Dampers Service / Sealing

- a. Dampers must be utilized with valving and internals as per the applicable Constructor's IMSA Technical Credential.
- b. Dampers must be used with intact seals.
- c. Dampers must be unmodified from the approved rebuilding and sealing vendor. The approved rebuilding and sealing vendor is:

Chassis Constructor	Damper	Address
Lamborghini	Ohlins	Ohlins North America Attn: Super Trofeo Service 703C Grove Street Hendersonville, NC 28792

- d. Entrant is responsible for all costs associated with the sealing program including seals, inspections, labor, shipping, and handling.

Entrant is responsible for shipping to the approved rebuilding vendor with adequate time for the vendor to perform the required service.



- e. Dampers must be identified with car number when in use and when being sealed.

Event	Event Date	Deadline to submit damper for service/sealing
Sebring	Mar 13-15	Feb 10
Laguna Seca	May 10-12	April 10
Watkins Glen	Jun 20-23	May 25
Circuit of the Americas	Aug 31 – Sep 1	Jun 30
Indianapolis Motor Speedway	Sep 20-22	Aug 20
Ohlins Work Order Form.PDF		
Submit service and sealing request to: Michael.Hodges@driv.com		
Fill out the Work Order Form above and send dampers with contact information and work order form to:		
Öhlins USA Attn: Super Trofeo Service 703C South Grove Street Hendersonville, NC 28792		

CAR BODY / INTERIOR

Overall car dimensions and overhangs

18. The total length of the car is 4,587 mm +/- 15mm

The track width of the front axle measured at the centre of wheel hub plugs is 1685 mm (+/- 20mm). The track width of the rear axle measured at the centre of wheel hub plugs is 1660 mm (+/- 20mm).

The front overhang is 1,106 mm (+/-15.0mm), measured from the middle of the wheel of the front axle to the leading edge of the car (first point in the direction of the longitudinal axis, including front lip).

The rear overhang is 849mm (+/-15.0mm), measured from the middle of the wheel of the rear axle to the rear edge of the car (last point in the direction of the longitudinal axis, rear wing excluded).

The wheelbase of the car is 2,622.0 mm +/-15.0 mm, measured at the centres of the wheel hubs.

19. Rear wing: The position of the rear wing must respect the following instructions:
 Angle of attack of the wing: it must be included in the range between +6° to +12°.

The car must have the original Lamborghini Huracan ST EVO2 wing supports. For the correct adjustment of the angle attack refer to the numbers and signs reported on car handbook.

Wing offset: with the car on a flat reference plane, the rear edge of the holder of the wing must be included between 1690 to 1697mm far from the bend of the roof for any adjustment of the angle of



attack within the range admitted.

The wing height and the wing offset are checked in the conditions in which the car ends the session.

The wing section profile must not be modified.

The two side wing end plates cannot be modified in profile and section, and they have to be always installed on the wing respecting the correct adjustment explained inside the car Handbook.

It is admitted to change the front aero using only the following original configuration:

Low downforce configuration:

as the car is delivered from Lamborghini Squadra Corse

High downforce configuration:

4TA898028A SKIDBLOCK FRONT SPLITTER RH

4TA898029A SKIDBLOCK FRONT SPLITTER LH

20. Cockpit

- a) Pedals: the brake and accelerator pedal surfaces may be customized but changes should not pose a threat to safety in any way.
All the pedal surfaces modifications must be approved by the Lamborghini technical delegates and scrutineers.
- b) Left side footrest removal is NOT ALLOWED.
- c) At least one video camera fixed inside the cockpit and pointed on the track in front of the car is mandatory. Position and safety fixing of the devices will be checked by Official Scrutineering.
- d) Lamborghini does not allow the installation and the use of a passenger seat in the Lamborghini Super Trofeo official events.

The use of the second seat is only permitted during private testing.

It won't be possible to participate at the event with the second seat on board.

The Competitors are not allowed to modify the brackets and/or the fixing points of the seat, which at all times must be in the original condition and/or in the available positions.

It is not permitted to use rails, brackets and any kind of non-original material to change the seat position.

- e) Only one spacer can be used directly between the steering wheel and the quick release system. Only spacers and screws provided by Lamborghini can be used (400419589 or 4TA898038).



- f) No part of car body may be improved, modified or material added. All parts must correspond in size, appearance and material to the originals. The original position of car body parts may not be altered, no adhesive tape affixed on bonnets, bumpers or doors, etc., modified to improve the car's aerodynamics.

On the Super Trofeo cars is allowed to Install the left and right side head restraint nets which comply with SFI 37.1 or FIA 8863-2013 but they must be checked and approved by the official technical scrutineers and the Lamborghini Squadra Corse technicians.

- g) The use of EVO2 body kit will be mandatory and fully assembled in the car following the user manual supplied by Lamborghini.
- h) Windscreen: To protect the windscreen and as a safety measure, 'tear-off' and Anti-fog screens are permitted to be attached to the windscreen. The layers applied must stay within the perimeter of the windshield and they cannot cover or close the outer edges between the windshield and the body. Fitting will be checked during technical scrutineering and must be removed where applicable on request of the Technical Scrutineers.
- i) The car has a roof hatch (to facilitate Driver extraction) which is connected to the roof via livelocks and which must be accessible at all times (no foiling or painting of live locks is permitted).

FUEL

21. All the cars must use the fuel supplied by Lamborghini during the event. No other type of fuel or additive are allowed.

The Technical Scrutineers shall be entitled to take fuel from a participant's car at any time during the event. The Competitor must ensure that at any time from the commencement of pre-start for any session or race until the car is released from Parc Fermé at the end of the respective session or race (subject to removal of fuel for the weighing procedure), a minimum of 3.0 liters of fuel can be taken from the corresponding removal point (defuelling coupling of the fuel cut-off valve). These samples must be identical to the reference fuel taken from the fuel supplier designated

The defuelling process will be done on the measuring platform of the Technical Scrutineering area. If necessary, the Technical Scrutineers may specify a different location. During the defuelling the vehicle must be stood on the platform (or the ground if a different location has been specified) on all four tyres and must not be moved.

The addition of any additives or any chemical changes to the fuel are prohibited. Cooling of the fuel is prohibited in any form.

Fuelling and refuelling of the cars during free practice, qualifying and the race is forbidden.

LUBRICANTS

22. All Competitors must only use the following lubricants for the related parts, namely:

Engine Oil:	CASTROL EDGE or SPORT 10W60
Gearbox Oil:	CASTROL SYNTRAX LONGLIFE 75W90 or MOTUL 300V LS SYNECO AMPLEX 75w90
Brake System Oil:	CASTROL SRF or BREMBO HTC64T
Hydraulic Power Steering Oil:	LIQUI MOLY ATF III
Cooling system:	WATER+ 5% WATER WETTER



SQUADRA CORSE

The addition of any additives or any chemical changes to the lubricants are prohibited.

In events with climatic conditions at high temperatures is recommended to use Water plus Water Wetter for better cooling.

During the Series events, lubricant samples can be taken for testing. All the cars, in order to be allowed to start the race, need to have all the lubricants reaching the full (high) level, and/or the level recommended by Lamborghini. The Technical Scrutineers will be in charge of this checking process, and at no time shall the Competitor try to avoid them.

SAFETY DEVICES

23. The car fully complies with the APPENDIX J (Article 277) of the International Sporting Code concerning the safety devices:

Brake system safety	(253-4)
Circuit breaker	(253-13)
Fuel tank FT3-1999, pipes, pumps and filter	(259-6.3 253-3.1 253-3.2 253-3.3 253-3.4 257A-6.3 259-6.4)
Carburant	(252-9)
Oil catch tank	(259-7.4)
Electric cables	(259-8.5)
Safety belts	(259-14.2.1)
Reverse gear	(275-9.3)
Suspension arm	(275-10.3.1 275-10.2)
Wheel material	(275-12.2)
Extinguisher	(253-7)
Rear view mirror	(253-9)
Rear light	(259-8.4.2)
Headrest	(259-14.4)
Towing eye	(259-14.6)
Firewall	(259-16.6)
Windscreen	(259-3.6)
Windscreen wiper	(259-3.6)
Roll cage	(253-8)
Seat	(253-16)
Roll cage padding	(253-8.3.5)
Ground clearance	(252-2.1)

All the aforementioned safety devices must be original.

Protective Padding :

Cars must be equipped with non-flammable protective padding with a valid label demonstrating compliance with one of the following standards:

Installation requirements:

- A. Padding must be located to protect the driver (body and/or helmet) against direct contact with the safety cage in a collision.
- B. Protective padding must be securely affixed to prevent rolling or displacement.

Cutting the Roll cage paddings IS NOT ALLOWED for any reason.



SQUADRA CORSE



Driver Seat:

Customizing the seat position is allowed only using the original holes in the brackets and in the seat. Modification of the brackets or creating a new holes are not permitted for any reason.

Fire Extinguisher System:

Cars must utilize the Homologated OMP Fire System as installed in the car and described in Manual documentation.

System must be securely mounted with zip ties with activation switch to the central dash and positioned so that the status light is visible from the passenger window.

The on-board fire extinguisher system must be switched into position "Armed" from the moment a car leaves its team area to travel to the pre-start area for each session and must not be switched off until the car is returned to the team area or Parc Fermé after the session.

A. The following must be visible without the use of photography, tools, or seat removal:

1. Pressure gauge (if present)
2. Date of manufacture
3. Next required service date

B. Nozzles must not point directly at the driver's face.

System must include an exterior activation mechanism proximal to the exterior master electrical switch at (or near) the base of the left side A-Pillar.

Exterior activation mechanism must be located such that emergency responders may activate with a single action:

1. Using a gloved finger, or tools such as a hook.
2. Unencumbered by bodywork, windscreen wipers, or any equipment that may require multiple actions.

Inspection:

A. Official Technical Delegate may require removal of the fire bottle for Technical Inspection.

B. Entrant is responsible to demonstrate proper system function of the interior and exterior fire extinguisher activation mechanisms, using the "test" mode if present.

Changing the number and the position of the nozzles and fire- extinguisher is not permitted.

The team is responsible for the correct maintenance and validity of the safety devices.

Master Electrical Switches:

Cars must be equipped with internal and external master electrical switches as homologated and installed as OE.

Systems must remain functional during any on-track activity or at the request of the Technical Scrutineers.

A. must be spark-proof, and when activated must:

1. De-energize all electrical circuits.
2. Stop the engine.

The internal master switches must be installed within the cockpit and located so the driver may activate the switch when seated in a normal position with safety belts fastened and steering wheel in place.

The external master switch must be installed proximal to the fire suppression control at (or near) the base of the left side A-Pillar.

A. External master switch must be located such that the emergency responders may activate with a singular action:

1. Using a gloved finger, or tools such as a hook.
2. Unencumbered by bodywork, windscreen wipers, or any equipment that may require multiple actions.

B. A method for preventing activation of the exterior master switch:

1. May be enabled when the car is in Technical Inspection, in the Paddock, or during pre-Race activities.
2. Must be removed prior to participation in on-track activity.

Interior and exterior master switches must be clearly identified by a symbol of a red spark surrounded by a white-edged, blue triangle with a base greater than 30 mm.

Front/ Rear tow:

The towing hooks must be correctly visible.

(see photo):



Front/ Rear Logo:

Front and Rear Lamborghini LOGO are mandatory (see pictures):



FT3-1999 FUEL SYSTEM

24. The only fuel system permitted to be installed to the Lamborghini Huracan ST EVO2 cars is from MY 2018 to MY2022 (fuel filter and regulator integrated on the fuel bladder).

Must equip the complete system including:

- FT3-1999 rubber fuel tank with internal foam (the total capacity with the foam is 118 L);
- 4 lift pumps and main fuel pump installed + a nourice (6l capacity);
- The internal fuel system layout Including fuel hoses and specific connections;



SQUADRA CORSE

- The external fuel system made of special fuel hoses with metallic protection and Ergal connections;
- The electrical wiring loom (fuel resistant);
- 1 fuel tank flange with non-return flap valve FIA homologated;
- 1 fuel tank flange with gravity activated roll-over valve;
- 1 ventilation/breather valve 200mbar homologated by FIA;
- 1 cut-off 'quick disconnect' connector;
- 2 safety filler necks;
- 2 refueling and ventilation plastic bottles;
- Carbon Fiber Protective Fuel Tank Case;
- 2 fuel sample/ and fuel tank drain connector;
- 1 automatic cut off valve

- a) All FIA certifications released to the team must be kept and will be object of inspection during the Lamborghini Super Trofeo official events. The FIA fuel tank homologation must be always visible in order to allow the necessary validity inspections;

IMPORTANT

Please note that the FT3- 1999 has a validity of 5 years from the date of manufacture indicated on the fuel tank. At the end of 5 years will be required:

- Revise the tank (by the manufacturer) with the extension of validity for 2 years;

Or

- Replace the tank.

- b) It is not permitted to perform any kind of modification to the FT3 fuel system;
- c) Lamborghini does not allow the use of non-certified materials and not conforming to the FT3 fuel cell;
- d) It is strictly forbidden to carry out any modification to the components of the original refueling system;
- e) All the teams must comply with the installation procedures supplied by Lamborghini;
Here below find the two options of fuel system scheme:

SPEC.1

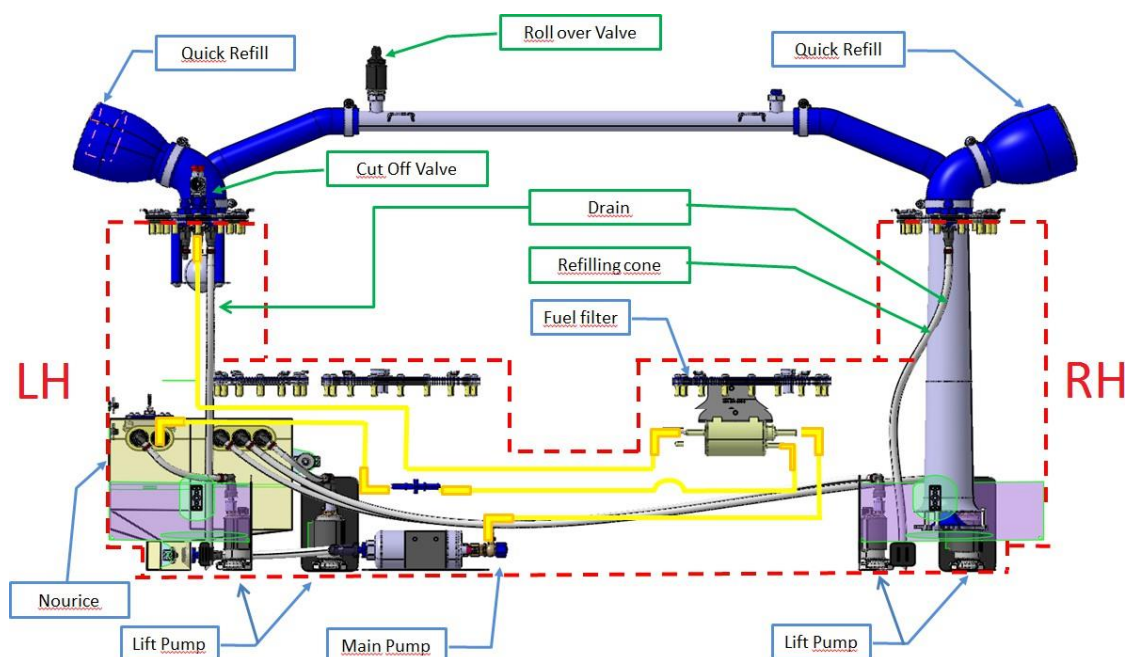



SQUADRA CORSE

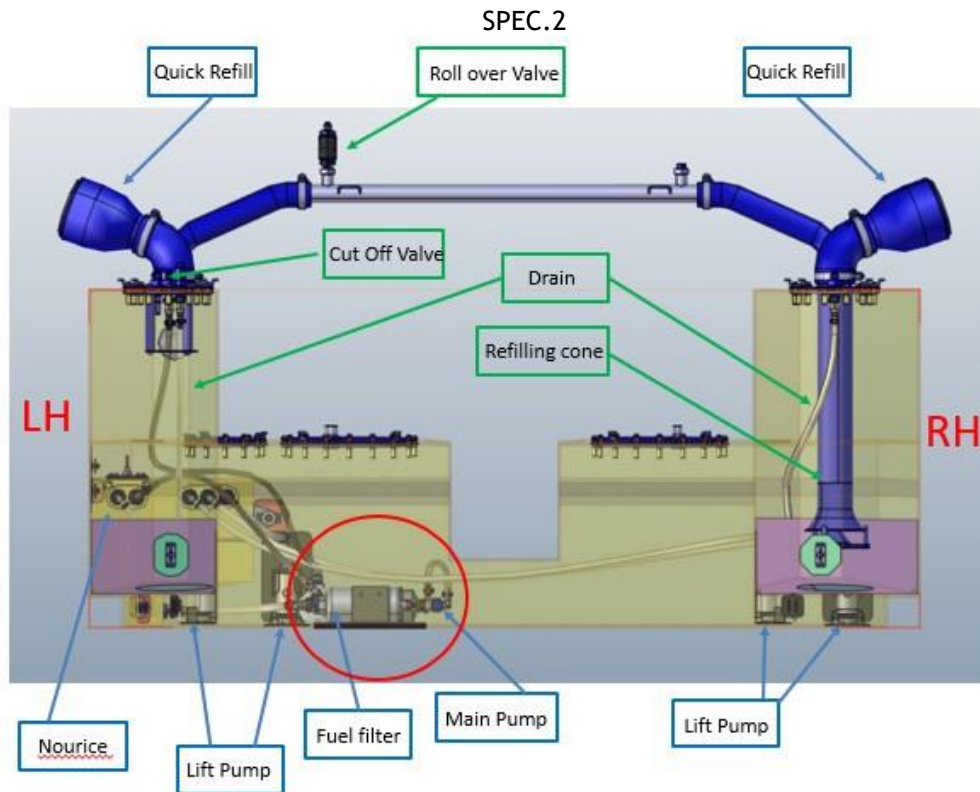

Main pump & fuel filter scheme (SPEC.2):

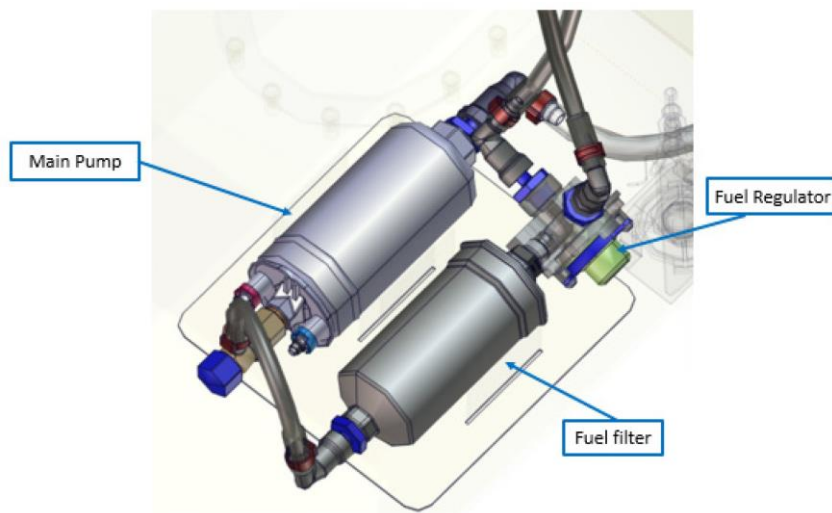

FINAL DIRECTIONS

25. Lamborghini reserves the right to change any clause and regulations herein at any time to ensure the successful outcome of the Lamborghini Super Trofeo.