



# IMSA GTP Scrutineering System

Manual

---

# Table of Contents

## Contents

<b>Manual</b> .....	<b>1</b>
<b>Table of Contents</b> .....	<b>2</b>
<b>1 Scope</b> .....	<b>4</b>
<b>2 Contact</b> .....	<b>4</b>
2.1 Sales.....	4
2.1.1 Track Sales.....	4
<b>3 Components</b> .....	<b>5</b>
3.1 Electronic Hardware .....	5
3.1.1 Logger - MS6 SCR .....	6
3.1.2 Display - XAP NTX.....	6
3.1.3 Telemetry – LTE65 .....	7
3.1.4 Accident Data Recorder .....	9
3.1.5 High Speed Camera.....	9
3.1.6 IMU/GNSS – VMPS.....	10
3.1.7 USB Stick/Diagnostic Port .....	12
3.1.8 X2 Transponders .....	13
3.1.9 Leaderlight Panels.....	13
3.1.10 Track Condition Radio .....	13
3.2 Sensors .....	14
3.2.1 1 Bar Pressure .....	15
3.2.2 3.5 Bar Boost Pressure .....	15
3.2.3 10 Bar Fuel Pressure/Temperature.....	15
3.2.4 Temp Sensor .....	15
3.2.5 LSU 4.9 Lambda Sensor.....	16
3.2.6 Engine Speed Sensor.....	16
3.2.7 Wheel Speed Sensors.....	17
3.2.8 Driveshaft Torque Sensors.....	17
3.2.9 Input Shaft Torque Sensor (Optional).....	17
3.2.10 Oil Catch Tank Level Sensor .....	17
3.2.11 Refueling Coupling Switch.....	17
3.2.12 Anti-Roll Bar Actuator Position Sensor .....	17
3.2.13 Air Jack Pressure Sensor.....	18
3.2.14 Fuel Tank Pressure .....	18
3.2.15 Fuel Tank Temperature .....	18
3.2.16 Fuel Flow Meter .....	18
3.2.17 IVT Sensor.....	18

3.2.18	Throttle Sensor .....	19
3.2.19	Tire Pressure Monitoring System (TPMS) .....	20
3.3	Sensor Declaration Form .....	20
3.4	Public CAN Bus Message Declaration.....	20
3.5	Component Seals .....	20
<b>4</b>	<b>System Architecture .....</b>	<b>21</b>
4.1	Team CAN .....	21
4.1.1	Team Connector – Scrutineering Harness .....	21
4.1.2	Hybrid Connector – Scrutineering Harness.....	22
4.1.3	CAN Bus Delta .....	23
4.1.4	CAN Bus Echo .....	23
4.1.5	CAN Bus Foxtrot .....	24
4.1.6	CAN Bus Golf .....	24
4.1.7	PPU Test mode Function Description .....	25
4.1.8	Driver ID .....	27
4.2	Power Supply .....	27
4.3	Harness.....	27
<b>5</b>	<b>CAN Specification.....</b>	<b>28</b>
<b>6</b>	<b>Display Pages.....</b>	<b>29</b>
6.1	Standard.....	29
<b>7</b>	<b>Loom Layout .....</b>	<b>30</b>
<b>8</b>	<b>Appendix.....</b>	<b>33</b>
<b>9</b>	<b>Vibration Profile 1 .....</b>	<b>45</b>
<b>10</b>	<b>Order Form.....</b>	<b>46</b>
<b>11</b>	<b>Revisions .....</b>	<b>52</b>

# 1 Scope

This document contains application notes on the installation and operation of the IMSA Scrutineering System.

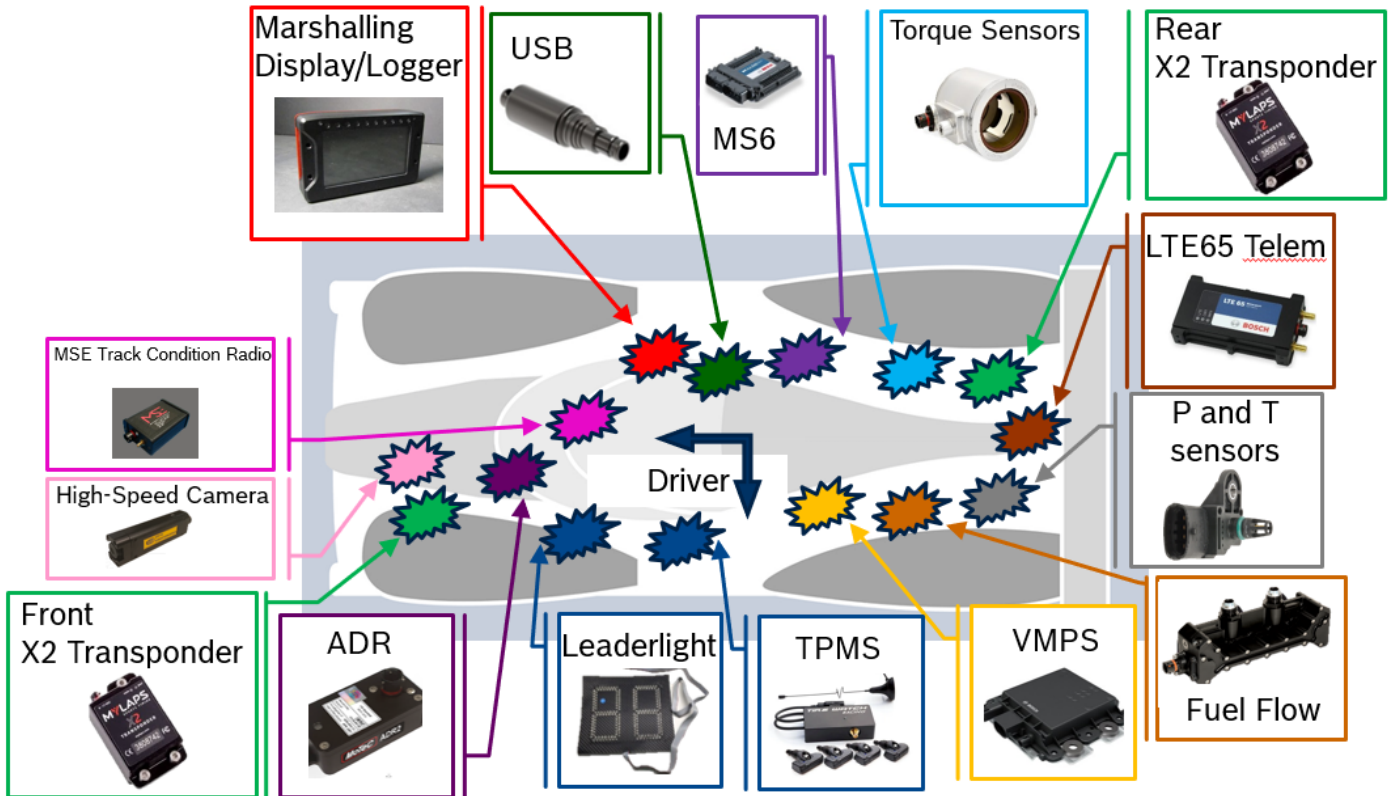

## 2 Contact

For technical information please contact:

[SUPPORT.IMSA@US.BOSCH.COM](mailto:SUPPORT.IMSA@US.BOSCH.COM)

### 2.1 Sales

Contact Bosch Motorsport for purchasing information via the contacts above.

For non-Bosch third-party parts order information, refer to IMSA documentation

#### 2.1.1 Track Sales

Customers requiring spare parts purchased and delivered at the racetrack are subject to a 10% service fee.

## 3 Components

### 3.1 Electronic Hardware

Component List:

Part Number	Name	Description
F02U.V03.353-01	Data Logger	Bosch MS6-SCR with USB
F02U.V0U.267-02	1 Bar Pressure	Air Pressure Sensor
F02U.V0U.204-01	1 Bar Pressure	Air Pressure Sensor (Automotive connector)
F02U.V0U.205-01	3.5 Bar Pressure	Boost Pressure Sensor
F02U.V02.356-01	Temperature Sensor	Air Temperature Sensor
F02U.V01.342-01	USB Stick	Scrutineering Data USB
0258.988.001	LSU 4.9	Lambda Sensor
F02U.V0U.194-01	Fuel Pressure and Temperature	Fuel Pressure and Temperature Sensor
F02U.V00.990-03	Air jack Pressure	Air Jack Pressure Sensor
F02U.V0U.445-01	VMPS	IMU with GPS Sensor
F02U.00U.081-01	VMPS Antenna	VMPS Antenna
F02U.V02.910-02	LTE65	Telemetry Modem
F02U.00U.087-01	LTE65 Antenna	LTE65 Antenna
	Leaderlight Panel*	Position Display
	X2 Transponder*	Timing Transponder
	Engine Speed**	RPM Sensor
	Fuel Flow*	Fuel Flow Sensor
	MSE System*	Track Condition Radio
	Pedal Position Sensor**	Driver Pedal Position Sensor
	Primary Torque Sensors**	Drive Shaft Torque Sensors
	Backup Torque Sensor**	Input Shaft Torque Sensor
	IVT**	LMH Hybrid Current Measurement Sensor
	HSC*	High-speed Camera
	XAP NTX*	Marshalling Display
	Fuel Tank Pressure**	Pressure Sensor inside the fuel tank
	Fuel Tank Temperature**	Temperature Sensor inside the fuel tank
	Wheel Speed**	Wheel Speed Sensor
	Oil Catch Tank**	Catch Tank Overflow Sensor
	Refueling Coupling**	Refueling Coupling Switch
	Anti-roll Bar Actuator**	Anti-roll Bar Actuator Position

\* Denotes component available from other IMSA suppliers. Please refer to IMSA documentation for ordering information

\*\* Denotes homologated component supplied by GTP Manufacturer

### 3.1.1 Logger - MS6 SCR

**Functional Description:** Logger for GTP Class Scrutineering System

**Homologation Mounting Note:**

- Device should be mounted in an easily accessible area that allows access to all main connectors. This device must be mounted away from heat sources. Note maximum temperature range below.
- This device should be mounted to sustain vibrations within the Vibration Profile 1 defined in the appendix.

**Part Number:** F02U.V03.353-01

**Temperature Range:** -20 to 80 °C

**Recommended Inspection:** 2 years or 220 hours

### 3.1.2 Display - XAP NTX

**Functional Description:** Marshalling Display for IMSA GTP Class Scrutineering System

**Homologation Mounting Note:**

- This device should be mounted so that the display can be easily seen by the driver while on course, and away from any heat sources.

**Brightness Control:** Brightness **must** be commanded via CAN by a dimming value of 0-255 (0 is full bright and 255 is off) for both LED and Screen brightness. The SCR then interpolates the 0-255 value to a 0-7 value sent to the NTX Display on CAN Foxtrot. Message details found in the DBC.

### 3.1.3 Telemetry – LTE65

**Functional Description:** Telemetry Radio for IMSA GTP Class Scrutineering System



External Antenna

**Homologation Mounting Note:**

- Device should be mounted in a dry area away from direct heat sources, and with the status LEDs plainly visible.
- Use of the specified antennas are required.
  - External antennas must be mounted as homologated.
- SMA cables are provided in the kit. Competitors can supply their own cables that have an impedance of 50Ω and meet or exceed the standards of RG316. The cable must be SMA male on both ends.
- This device should be mounted to sustain vibrations within the Vibration Profile 1 defined in the appendix.

**Part Number:** F02U.V02.910-02

**External Antenna Parts:**

**Antenna Part Number:** F02U.00U.087-01

**SMA Bulkhead:** F02U.00U.088-01

**Cable (if not provided by competitor):** F02U.00U.089-01 (66" length) OR F02U.00U.089-02 (120" length)

**Temperature Range:** -30 to 65 °C

**Team Private Telemetry Stream:** Each individual team will be allowed a stream that is sent to the telemetry radio via RS232 at 115.2K Baud. The stream can be from any data logger type and is not decoded by the scrutineering system - allowing for free control of the telemetry stream by competitors.

### External Antennas Installation

- Ground plane is required.
  - Can be made with copper tape – is included in the kit if needed.
  - Use heli-tape or similar to isolate the ground plane from the body panel.
  - Size: 4" x 5" (3" x 4" is minimum size)
  - Ground planes must not be shared between devices.

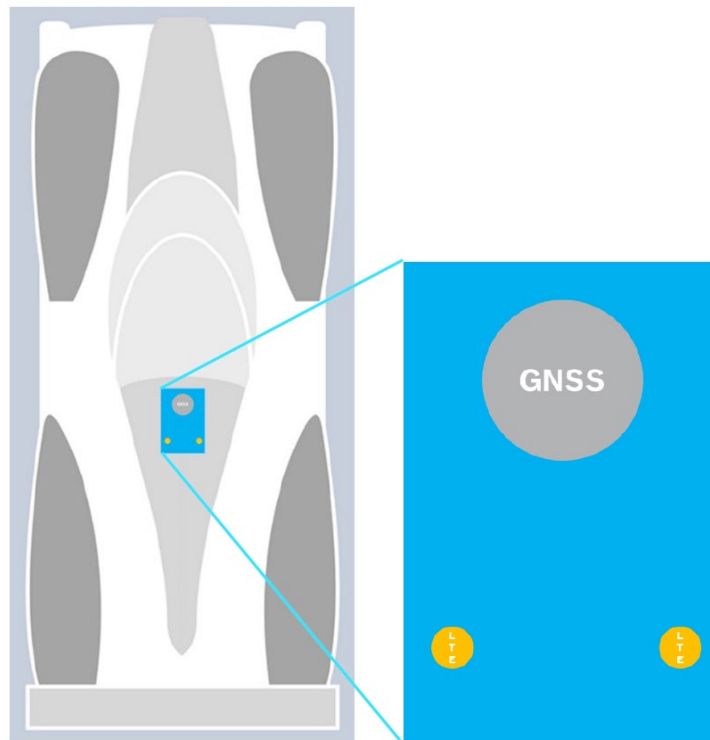
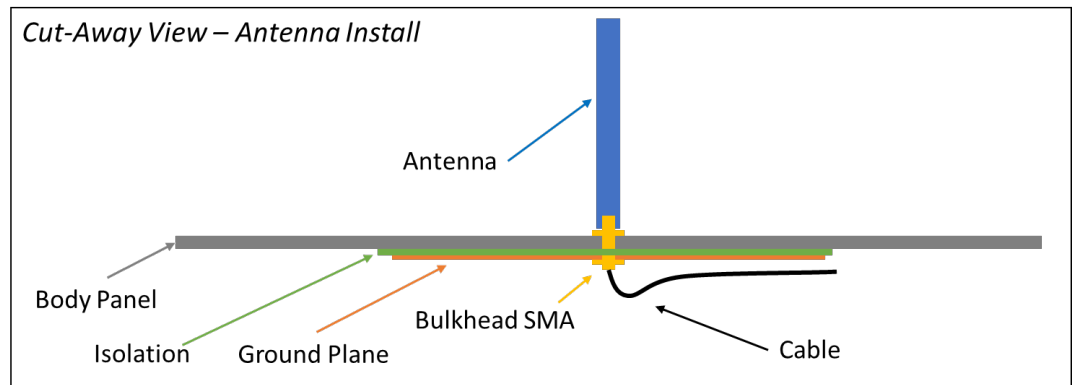

### 3.1.4 Accident Data Recorder

**Functional Description:** Accident Data Recorder for IMSA GTP Class Scrutineering System

**Homologation Mounting Note:**

- Device should be mounted in an easily accessible area that allows access to all main connectors. This device must be mounted away from heat sources.
- See LMDh and LMH Technical Regulations regarding installation requirements.

### 3.1.5 High Speed Camera

**Functional Description:** High Speed Camera for GTP Class Scrutineering System

**Homologation Mounting Note:**

- See LMDh and LMH Technical Regulations regarding installation requirements.

## 3.1.6 IMU/GNSS – VMPS

**Functional Description:** 6 axis inertial measurement unit with GNSS.

**Homologation Mounting Note:**

- Device should be mounted in an easily accessible area that allows access to all main connectors. This device must be mounted away from heat sources.
- Device must be installed with supplied mounting hardware.
  - Using provided grommets as shown below.
  - Vibration isolating mounts are preferred but not required.
  - The metal housing should not be allowed to contact any part of the chassis during normal operating conditions.
  - Using 3x M6 bolts or studs, competitors to provide.
- Device to be mounted:
  - With connector interfaces facing towards the rear of the car
  - Aligned within 1 degree of vehicle centerline.
  - Within 0.5 degrees of horizontal
  - Nearest to vehicle center of gravity as possible
- Use of the specified antenna is required.
  - Antenna must be mounted as homologated.
  - An SMA cable is provided in the kit.
    - Competitors can supply their own cables that have an impedance of 50Ω and meet or exceed the standards of LMR-100A.
    - The length of the cable is not to exceed 3 meters.
    - All reasonable efforts should be made to run the antenna cable away from strong sources of electrical noise, including but not limited to:
      - TV cameras and cables
      - Ignition cables
      - Radio transmitters and cables
      - High voltage sources

**Part Number:** F02U.V0U.445-01

**Antenna Part Number:** F02U.00U.081-01

**Temperature Range:** -40 to 65 °C

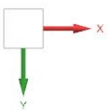
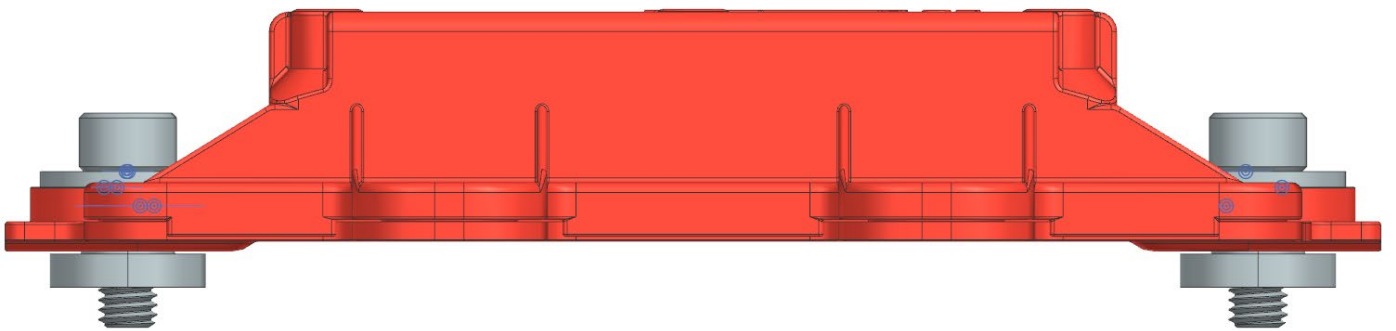
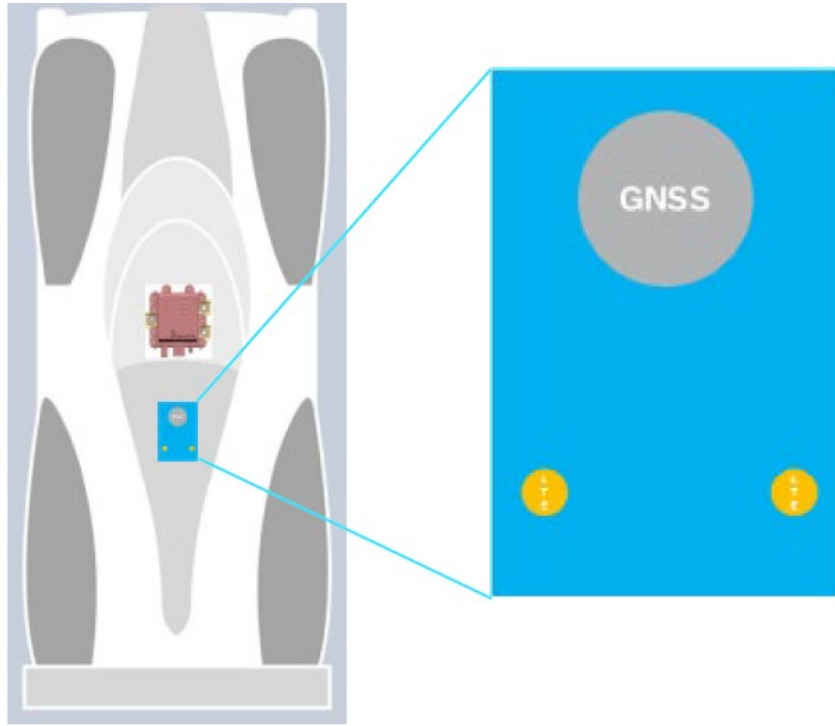

## 3.1.7 USB Stick/Diagnostic Port

**Functional Description:** IMSA Scrutineering USB Stick and Diagnostic Port

**Homologation Mounting Note:**

- Device and diagnostic connectors must be mounted in an area easily accessible via the passenger side door opening.
- IMSA Scrutineering, Safety, and USB ports must be **clearly labeled as SCRUT, SAFETY, and IMSA USB** respectively, as shown in the example below. These labels must be in the line of sight of the open door, not hidden behind or under other components.
- These ports must be mounted securely, so that the USB stick and diagnostic connector can be inserted and removed with one hand.
- USB Wiring must be shielded. See wiring schematic for more details.
- Mounting example:



**Temperature Range:** -40 to 85 °C

**Removal Note:** To remove the USB stick from the connector, the collar at the connector end of the USB stick must be pulled away from the connector. Do not pull on the main body to remove.



**USB Stick Possession:** IMSA will distribute and collect USB Sticks at every race; teams will not receive sticks with scrutineering components, nor are they required to purchase these separately.

### 3.1.8 X2 Transponders

**Functional Description:** CAN based transponder for IMSA GTP Class Scrutineering System

**Homologation Mounting Note:**

- Each car will carry two X2 Transponders.
- The Main Transponder should be mounted at the front of the car, and the Backup Transponder should be mounted in the rear of the car. The designation of the transponders will be based on the CAN layout detailed in section below.
- Refer to technical regulations for mounting location.

**Temperature Range:** 0 to 60 °C

### 3.1.9 Leaderlight Panels

**Functional Description:** Leaderlight panels

**Homologation Mounting Note:**

- This device(s) must be fitted securely.
- Refer to technical regulations for mounting location.

The pinout of the leaderlight power connector/s is shown in the table. No changes are allowed to this arrangement. This connector is for providing power to the leaderlights from the team harness.

**Team Harness Connector:** AS(0/1)10-98SN

**Scrutineering Harness Connector:**

Connector	AS610-98PN
Pin #	Signal
1	LeaderLight-12V
2	LeaderLight-12V
3	LeaderLight-12V
4	LeaderLight-GND
5	LeaderLight-GND
6	LeaderLight-GND

### 3.1.10 Track Condition Radio

**Functional Description:** Track condition radio system for FCY notification

**Homologation Mounting Note:**

- This device(s) must be fitted securely.
- Refer to technical regulations for mounting location.

## 3.2 Sensors

This section declares sensors that must be directly connected to the IMSA scrutineering system. IMSA will define required engine sensors and locations for each engine application. These signals will be fed back to the teams via CAN.

For all sensors refer to the Homologation for installation and mounting location with numbering referring to the fed engine bank.

As a reference to the technical regulations, all GTP cars must run:

- Cockpit Temperature
- Wheel Speed Sensors (one per wheel)
- Tire Pressures (one per wheel)
- Driveshaft Torque Sensors
- Input Shaft Torque Sensor (Optional)
- Anti-roll Bar Actuator Position Sensor
- Air Jack Pressure Sensor
- Refueling Coupling Sensor
- IVT Sensor (LMH Hybrid Only)
- Engine Sensors
  - Driver's Throttle Pedal Sensor
  - Manifold Pressure(s) (NA only)
  - Manifold Temperature(s)
  - Boost Pressure(s) (Turbo only)
  - Fuel Pressure/Temperature
  - Lambda(s)
  - Fuel Flow Meter
  - Engine Speed Sensor
  - Oil Catch Tank Level Sensor
  - Fuel Tank Pressure
  - Fuel Tank Temperature

Sensors must be installed in an IMSA approved location as identified in the Homologation with numbering referring to the fed engine bank.

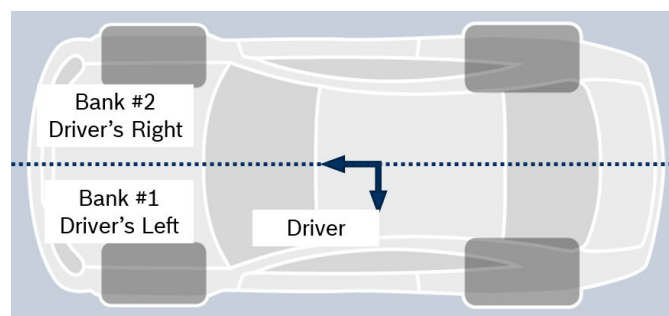

### 3.2.1 1 Bar Pressure

**Functional Description:** Air pressure sensor

**Use Case:**

- **Manifold Pressure (NA engines):** The sensor must be fitted in each intake manifold downstream the throttle valve—for example, in the intake runners or intake ports—in an IMSA approved location.

**Part Number:** F02U.V0U.267-02 (A/S terminated) or F02U.V0U.204-01 (Automotive Connector)

**Pressure Range:** 0.1 – 1.15 bar

**Temperature Range:** -40 to 125°C

### 3.2.2 3.5 Bar Boost Pressure

**Functional Description:** Boost pressure sensor

**Use Case:**

- **Boost Pressure (Turbo engines):** The sensor must be fitted to measure pressure in each intake manifold downstream the throttle valve in an IMSA approved location.

**Part Number:** F02U.V0U.205-01

**Pressure Range:** 0.5 – 3.5 bar

### 3.2.3 10 Bar Fuel Pressure/Temperature

**Functional Description:** Fuel Pressure/Temperature sensor

**Use Case:**

- **Fuel Pressure/Temperature:** The sensor must be fitted to the fuel line at the level of the feed line fuel flow meter(s) (max 20cm from FFM inlet(s))
  - Pressure is the only measured signal.

**Part Number:** F02U.V0U.194-01

**Pressure Range:** 0 – 10 bar

### 3.2.4 Temp Sensor

**Functional Description:** Temperature sensor

**Use Case:**

- **Manifold Temperature:** On each independent intake manifold in an IMSA approved location close to the Boost/Manifold pressure sensor
- **Intake Temperature:** A single sensor must be installed in an IMSA approved location.
- **Cockpit Temperature:** In the cockpit, mounted per Technical Regulations

**Part Number:** F02U.V02.356-01

**Temperature Range:** -55 to 300 °C

**Thread:** M6 x 1

**Installation Torque:** 8 Nm

## 3.2.5 LSU 4.9 Lambda Sensor

**Functional Description:** Exhaust gas lambda sensor

**Use Case:**

- See Appendix for required sensor mounting information.
- One sensor per cylinder bank is required.
- IMSA Sensor should be mounted as close to Team Sensor as possible

**Part Number:** 0258.988.001

**Thread:** M18 x 1.5

**Installation Torque:** 40 to 60 Nm

## 3.2.6 Engine Speed Sensor

**Functional Description:** Inductive or Hall effect speed sensor

**Use Case:**

- Each manufacturer may select a sensor and trigger wheel pattern to be approved by IMSA.
- See below for application recommendation. Trigger wheel must include 30-60 teeth and must include 1-4 missing teeth in 1 spot around the wheel.
- If choosing an inductive sensor, the depth of the missing tooth gap must be half the depth of the normal gaps.
- If choosing an inductive sensor, polarity for pin 2 is positive, and pin 3 is negative.
- Wiring from sensor to MS6 SCR must be twisted and shielded.

**Recommendation:**

- Bosch P/N: Mini HA-P: **F02U.V00.564-02**  
Mini HA-P (Sealed): **F02U.V00.500-01**
- 60 tooth symmetrical wheel, 2 missing teeth

**Trigger Wheel Recommendation (for HA-P above):**

- Diameter: 162.34mm
- Gap Width: 4.7mm
- Tooth Width: 3.8mm
- Missing Tooth Gap Width: 20.79mm
- Height of tooth: 3.4mm
- Thickness: 12.5mm
- Sensor Air Gap: 0.2 to 1.5mm

### 3.2.7 Wheel Speed Sensors

**Functional Description:** Hall Effect Speed Sensor

**Use Case:**

- Each manufacturer may select a sensor and trigger wheel pattern to be approved by IMSA.

### 3.2.8 Driveshaft Torque Sensors

**Functional Description:** CAN based driveshaft torque sensor for IMSA GTP Class Scrutineering System

- CAN buses must be laid out in a linear fashion, with 120Ω termination resistors are required at both ends of each bus.
- The interfaces for the Scrutineering Harness to Team (contains Torque Master) must follow the specified pinout.
- Analog inputs required to be wired according to the wiring diagram below for all new looms.
- Sensor required to be wired to the scrutineering logger (reference the wiring diagram blocks C17 for left side and C18 for right side)
- On driveshaft of each driven wheel
- Team must be able to send CAN message to trigger offset calibration for each sensor

### 3.2.9 Input Shaft Torque Sensor (Optional)

**Functional Description:** CAN based Input Shaft torque sensor for IMSA GTP Class Scrutineering System

- On input shaft of transmission
- Sensor is optional, but must be included on public CAN Bus for it to be potentially used as a backup in the case of driveshaft torque sensor failure
- Team must be able to send CAN message to trigger offset calibration

### 3.2.10 Oil Catch Tank Level Sensor

**Functional Description:**

**Use Case:**

- See technical regulations for placement

### 3.2.11 Refueling Coupling Switch

**Functional Description:**

**Use Case:**

- See technical regulations for placement

### 3.2.12 Anti-Roll Bar Actuator Position Sensor

**Functional Description:**

**Use Case:**

- See technical regulations for placement

### 3.2.13 Air Jack Pressure Sensor

**Functional Description:** Air Jack Pressure Sensor

**Use Case:** Sensor must be mounted to show a pressure reading when the air jacks are deployed

**Part Number:** F02U.V00.990-03 (A/S Terminated) - or - 0261.545.040 (Prod. Conn)

**Pressure Range:** 0 – 260 bar

### 3.2.14 Fuel Tank Pressure

**Functional Description:**

**Use Case:**

- See technical regulations for placement
- Sensor for FIA scrutineering system is to be used.

### 3.2.15 Fuel Tank Temperature

**Functional Description:**

**Use Case:**

- See technical regulations for placement  
Sensor for FIA scrutineering system is to be used.

### 3.2.16 Fuel Flow Meter

**Functional Description:** CAN based fuel flow meter for IMSA GTP Class Scrutineering System

- On each feed and any return line if applicable.
- Use CAN-ID 0x190 (R=22kohm) for Feed1, 0x194 (R=5.6kohm) for Feed2, 0x198 (R=1.8kohm) for Return line

**Mounting Note:** Refer to technical regulations for mounting location.

**Temperature Range:** 0 to 85 °C

### 3.2.17 IVT Sensor

**Functional Description:**

**Use Case:**

- See technical regulations for placement

## 3.2.18 Throttle Sensor

### Functional Description:

#### Use Case:

- See technical regulations for placement
- The throttle position sensor must have a working range of at least 2.5V

#### Throttle Pedal Calibration Instructions:

- Step 1: Team Side Pedal Calibration:  
Begin by calibrating the team side pedal. This step is crucial as the calibration process relies on the team pedal for a plausibility check. If the team side pedal has been moved since its last calibration, the SCR pedal calibration will be rejected.
- Step 2: Low Side Pedal Calibration:  
Once the team side pedal is calibrated, proceed with the low side (0%) pedal calibration.
  - Ensure the driver is off the throttle pedal.
  - Send a value of **1** on the signal **Team\_SCR\_APS\_Cal\_Min** via **msg 229 Echo**.
  - Monitor the signal **IMSA\_SCR\_APS\_Cal\_Status** on **msg 264 Echo**.
  - If the calibration is successful, this signal will display a value of **1**, indicating that the calibration for the release pedal is complete.
- Step 3: High Side Pedal Calibration:  
After successfully completing the low side calibration, verify that the signal **IMSA\_rThrottlePedal** on **msg 25F Echo** reads **0%** when driver is off throttle. Then, proceed with the high side (100% / Wide Open Throttle) calibration.
  - Instruct the driver to press the throttle pedal to full throttle.
  - Send a value of **1** on the signal **Team\_SCR\_APS\_Cal\_Max** via **msg 229 Echo**.
  - Again, monitor the signal **IMSA\_SCR\_APS\_Cal\_Status** on **msg 264 Echo**.
  - If the calibration is accepted, this signal will display a value of **2**, indicating that the calibration for the fully pressed pedal is complete. You can confirm this by ensuring that signal **IMSA\_rThrottlePedal** on **msg 25F Echo** reads **100%** when driver is at full throttle.
- Step 4: Calibration Check:  
To confirm the accuracy of the calibration, compare the signal **IMSA\_rThrottlePedal** on **msg 25F Echo** with the team side pedal calibration. Ensure that both readings are identical to validate the calibration process.

**Note:** Always ensure that all steps are followed in sequence for accurate and correct calibration.

## 3.2.19 Tire Pressure Monitoring System (TPMS)

**Functional description:** CAN based tire pressure and temperature sensor system (One sensor per wheel)

- Only TPMS systems Homologated on FIA TECHNICAL LIST N° 106 are permitted.
- The TPMS system must be connected to scrutineering CAN bus Echo
  - The scrutineering expansion connector may be used to access CAN bus Echo
  - New loom constructions may choose to wire the TPMS CAN connections directly to CAN bus Echo
  - The use of a CAN gateway device is permitted with IMSA approval. Manufacturers are open to source their own gateway.
    - The TPMS messages must be transmitted to and received on CAN Echo as they are received by the gateway device (one-to-one).
    - Transmit speed of 0x500 and 0x281 are to be sent at a cycle at 100 milliseconds.
    - Manufacturers must provide the gateway manufacturer documentation and configuration software to IMSA to allow for scrutineering.

## 3.3 Sensor Declaration Form

Prior to each event, a **Sensor Declaration Form** must be submitted via the IWSC regulations.

## 3.4 Public CAN Bus Message Declaration

Manufacturers must submit a **Public CAN Message Declaration Form** that includes all the messages that the manufacturer is sending on scrutineering CAN bus Delta and Echo, minus the required messages defined in IMSA CAN Public 1 and 2 DBC's.

- If there are team-specific messages being sent on the public CAN busses, Manufacturers must submit a form for each team specific deviation from the Manufacturer declaration.
- If the messages change between events the Public CAN Message Declaration Form must be resubmitted.

## 3.5 Component Seals

All Scrutineering system primary components (MS6, LTE65, VMPS) must have no evidence of tampering with the device.

## 4 System Architecture

### 4.1 Team CAN

#### 4.1.1 Team Connector – Scrutineering Harness

The pinout of the Team Connector is shown in the table. No changes are allowed to this arrangement. Termination of the CAN busses must be done in the car's loom as depicted in 4.1.3, 4.1.4, 4.1.5 and 4.1.6.

**Team Harness Connector:** AS(0/1)14-35SN

**Scrutineering Harness Connector:**

Connector	AS614-35PN
Pin #	Signal
1	CAN_Delta-SHD-IN
2	CAN_Delta-Hi-IN
3	CAN_Delta-Lo-IN
4	CAN_Delta-SHD-OUT
5	CAN_Delta-Hi-OUT
6	CAN_Delta-Lo-OUT
7	CAN_Echo-SHD-IN
8	CAN_Echo-Hi-IN
9	CAN_Echo-Lo-In
10	CAN_Echo-SHD-OUT
11	CAN_Echo-Hi-OUT
12	CAN_Echo-Lo-OUT
13	Telem RS232 – TX (if team is using the series LTE65)
14	RS232-GND
15	MED LED +12V
16	MED LED GND
17	FIA CAN4
18	FIA CAN4
19	FIA CAN4
20	FIA CAN4
21	
22	
23	
24	
25	
26	KL.30
27	KL.30
28	KL.30
29	KL.30
30	KL.30
31	KL.30
32	KL-31
33	KL-31
34	KL.31
35	KL.31
36	KL.31
37	KL.31

## 4.1.2 Hybrid Connector – Scrutineering Harness

The pinout of the Hybrid Connector is shown in the table. No changes are allowed to this arrangement. Termination of the CAN busses must be done in the car's loom as depicted in 4.1.3, 4.1.4, 4.1.5 and 4.1.6.

**Team Harness Connector:** AS(0/1)12-35SN

**Scrutineering Harness Connector:**

Connector	AS612-35PN
Pin #	Signal
1	CAN_Delta-SHD-IN
2	CAN_Delta-Hi-IN
3	CAN_Delta-Lo-IN
4	CAN_Delta-SHD-OUT
5	CAN_Delta-Hi-OUT
6	CAN_Delta-Lo-OUT
7	CAN_Echo-SHD-IN
8	CAN_Echo-Hi-IN
9	CAN_Echo-Lo-In
10	CAN_Echo-SHD-OUT
11	CAN_Echo-Hi-OUT
12	CAN_Echo-Lo-OUT
13	CAN_Foxtrot-SHD
14	CAN_Foxtrot-Hi
15	CAN_Foxtrot-Lo
16	CAN_Golf-SHD-IN
17	CAN_Golf-Hi-IN
18	CAN_Golf-Lo-IN
19	CAN_Golf-SHD-OUT
20	CAN_Golf-Hi-OUT
21	CAN_Golf-Lo-OUT
22	

### 4.1.3 CAN Bus Delta

CAN Bus Delta is the same layout as FIA CAN 1 Public.

- The order of components and compartment interfaces is open to constructors.
- CAN buses must be laid out in a linear fashion, with 120Ω termination resistors are required at both ends of each bus.
- The interfaces for the Scrutineering Harness to Team (contains Torque Master) and Scrutineering Harness to Hybrid Harness (LMDh only) must follow the specified pinout.
- Additional components are required for LMH Hybrid as defined in the technical regulations
- Only LMDh vehicles will have the HCU.
- Bus load must be kept at or below 70%. IMSA may install a CAN logging device to test bus load as required.

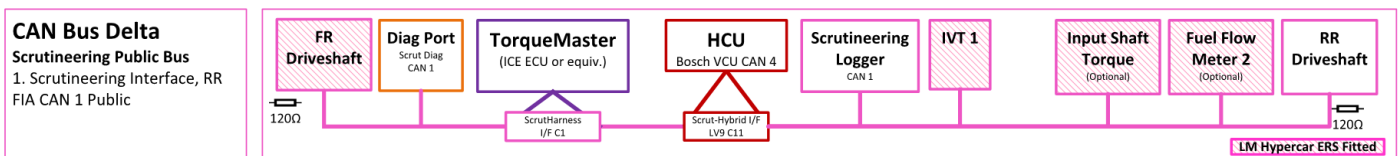

### 4.1.4 CAN Bus Echo

CAN Bus Echo is the same layout as FIA CAN 2 Public.

- The order of components and compartment interfaces is open to constructors.
- 120Ω termination resistors are required at both ends of the CAN bus.
- CAN buses must be laid out in a linear fashion, with 120Ω termination resistors are required at both ends of each bus.
- The interfaces for the Scrutineering Harness to Team (contains Torque Master) and Scrutineering Harness to Hybrid Harness (LMDh only) must follow the specified pinout.
- Additional components are required for LM Hypercar with ERS fitted.
- Only LMDh vehicles will have the HCU.
- Bus load must be kept at or below 70%. IMSA may install a CAN logging device to test bus load as required.

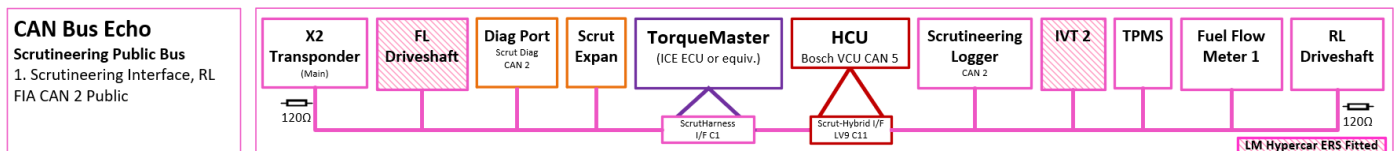

## 4.1.5 CAN Bus Foxtrot

CAN Bus Foxtrot is a private CAN bus for the scrutineering system.

- The order of components and compartment interfaces is open to constructors, with the exception of the HCU.
  - Only LMDh vehicles will have the HCU.
  - The interface from the Scrutineering Harness to Hybrid Harness must follow the specified pinout.
  - The HCU must be located at the end of the CAN bus.
- 120Ω termination resistors are required at both ends of the CAN bus.
  - In vehicles with an HCU, the termination resistor is included in the Hybrid Harness.
- CAN buses must be laid out in a linear fashion, with 120Ω termination resistors are required at both ends of each bus.

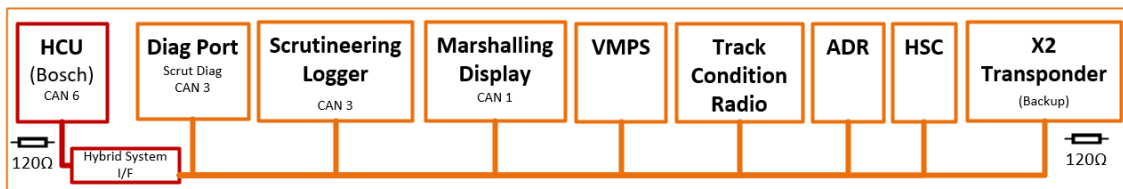

## 4.1.6 CAN Bus Golf

CAN Bus Golf is a private CAN bus for the scrutineering system.

- The order of components and compartment interfaces is open to constructors, with the exception of the HCU.
  - Only LMDh vehicles will have the HCU.
  - The interface from the Scrutineering Harness to Hybrid Harness must follow the specified pinout.
- 120Ω termination resistors are required at both ends of the CAN bus.
  - In vehicles with an HCU, the termination resistor is included in the Hybrid Harness.
- CAN buses must be laid out in a linear fashion, with 120Ω termination resistors are required at both ends of each bus. HCU can be located at end or in middle of bus.

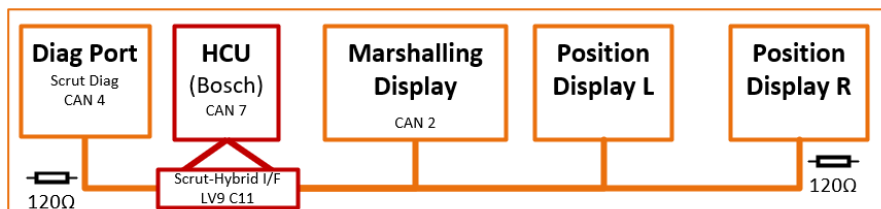

## 4.1.7 PPU Test mode Function Description

This section outlines how to use the "Test Mode" feature, which allows teams to run custom Power limits and Energy Tank limits during private, non-sanctioned testing.

- **Key Features of Test Mode**

- **Custom Limits:** Set your own PPU power limits and energy tank capacity.
- **Automatic Control:** Test Mode is automatically disabled during all official IMSA sessions and re-enabled a set time after the session concludes.
- **Standardized Conditions:** While in Test Mode, the atmospheric correction factor is automatically set to 1.0.

- **How to Use Test Mode**

Follow these steps to activate and configure Test Mode. Team-sent signals are transmitted on CAN Delta message 0x270 and Can Echo 0x229.

- **Step 1: Activate Test Mode**

To activate Test Mode, send a non-zero value for the energy tank limit.

- **Set Energy Tank Capacity:**

- **Bus:** Delta
- **Message ID:** 0x270
- **Signal:** Team\_TESTONLYPPUEnergyStint
  - The value sent via Team\_TESTONLYPPUEnergyStint directly sets the PPU Energy Tank capacity.
- **Units:** Megajoules (MJ)
- **Precision:** Single decimal
- **Max Value:** 6553.5 MJ

- **Value:** Send any value greater than 0 MJ. For example, sending 300.0 will activate Test Mode and set the energy tank capacity to 300.0 MJ.

- **Note:** If this signal is 0 or not sent, Test Mode will be inactive.

- **Step 2: Confirm Test Mode is Active**

Visually check the car's leader lights. When Test Mode is active, the car number will flash, alternating between its official class color and **purple**.

- **Step 3: Configure PPU and Energy Limits**

Once Test Mode is active, you can define your testing parameters.

- **Adjust PPU Power Limit:**

- **Bus:** Delta
- **Message ID:** 0x270
- **Signal:** Team\_TESTONLYPPULimitOffset
- **Units:** Kilowatts (kW)
- **Format:** Signed integer (positive values increase power, negative values decrease it).
- **Range:** -127 kW to +127 kW

- **Notes:** Send an offset value to modify the car's last calibrated Balance of Performance (BOP) power curve. The PPU integrator functions normally but uses this adjusted limit.

- **Step 4: Simulating On-Track and Pit Lane States**

To test regulatory functions like refueling, you must manually switch the car between "pit lane" and "on track" states.

- Sending Track Loops:
  - **Bus:** Echo
  - **Message ID:** 0x229
  - **Signal:** Team\_X2LongID\_TestMode
  - Track loop ID
  - **Units:** N/A
  - **Precision:** Unsigned integer
  - **Max Value:** 255
- **To Refuel (Enter Pit Lane Mode):**
  - Send a value of 40 on the Team\_X2\_LongID\_TestMode signal. This simulates entering the pit lane and allows the PPU Energy Tank to be refueled.
- **To Run (Enter On-Track Mode):**
  - Send a track loop ID (any value from 1 to 39) on the Team\_X2\_LongID\_TestMode signal. This simulates crossing a timing loop on track and activates standard track-running functions.

- **Additional Information:**

- You can send additional adjustment values for the PPU Limit and Energy Tank using CAN Delta message 0x269.
- If values are sent on this message, they will be added to the primary values being sent on message 0x270. This allows for fine-tuning or dynamic adjustments on top of your base settings.
  - $\text{PPU Limit Final Value} = (\text{Value from msg 0x270}) + (\text{Value from msg 0x269})$
  - $\text{Energy Stint Final Value} = (\text{Value from msg 0x270}) + (\text{Value from msg 0x269})$

- **Technical Reference:**

*For complete signal specifications (unsigned/signed format, precision, etc.), refer to the latest CAN communication spec (.DBC file) available on the IMSA Competitor portal.*

### 4.1.8 Driver ID

The Driver ID will be an input to a dedicated connector on the harness. The Driver ID signal will be controlled by a different resistance value for each driver. The resistor will go between the two pins for Driver ID with nothing else in the circuit. The Driver ID and resistor value pairings are in the table below:

ID	Resistor Value (Ohm)
1	0
2	820
3	2.2K
4	4.7K
5	12K

## 4.2 Power Supply

All power supplied should be at least 11.0V and below 15.0V. Power must always remain supplied when the car is in pit-lane or on-track. Interruptions of specified scrutineering power may result in IMSA applied penalties.

## 4.3 Harness

The scrutineering system harness can be integrated into the main vehicle harness following guidelines provided by Bosch and in compliance with IMSA regulations. Harnesses for teams must be manufactured by the GTP manufacturer and per the homologation. Manufacturers must register drawings and pinouts per the IMSA homologation documentation. IMSA reserves the right to request testing of any portion of the scrutineering harness at any time; no annual re-certification is required.

## 5 CAN Specification

There are two IMSA CAN interfaces that may be used for communication, on these buses the team is required to send all messages specified in the provided DBC.

GTP Manufacturers will be responsible for informing IMSA and Bosch which buses will be used for ECU and team communications as per Section 3.4 of this manual. These messages may be on the same bus.

CAN Buses:

The CAN buses will be used to transfer vital information between the team and the Scrutineering System. The buses are required to be 1 Mbit and conform to CAN 2.0B specifications.

The DBC file for the transmitted and received channels will be available at <https://www.imsa.com/competitors/>.

## 6 Display Pages

### 6.1 Standard

While on track the display will show:

- Current Driver ID
- Current Laptime
- Last Laptime
  - Note: The laptimes shown are calculated internally and are not the timing and scoring laptimes.

# 7 Loom Layout

# IMSA Scrutineering

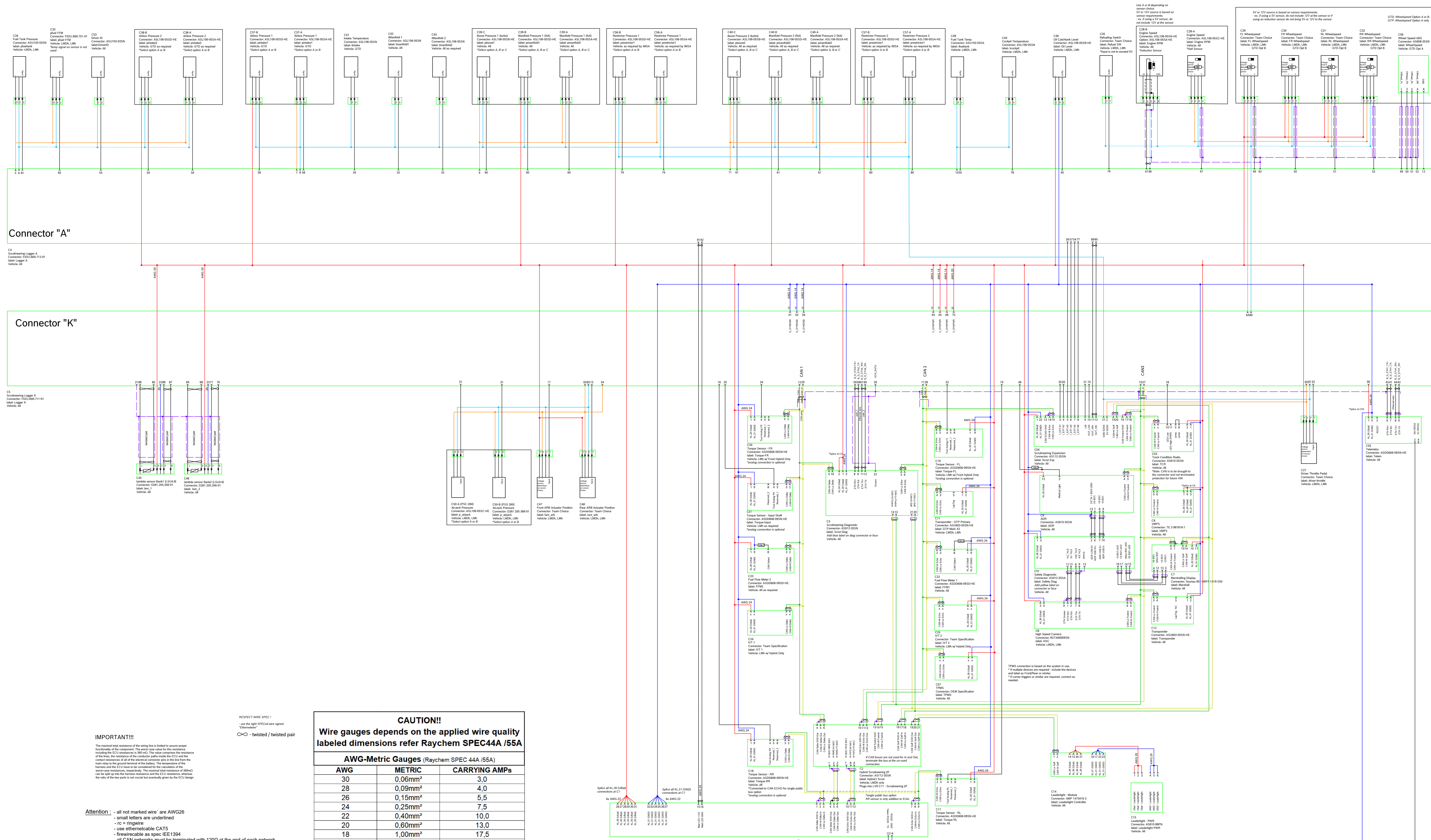

**CAUTION!!**  
Wire gauges depends on the applied wire quality  
labeled dimensions refer Raychem SPEC44A /55A

AWG	METRIC	CARRYING AMPS
30	0,06mm <sup>2</sup>	3,0
28	0,09mm <sup>2</sup>	4,0
26	0,15mm <sup>2</sup>	5,5
24	0,25mm <sup>2</sup>	7,5
22	0,40mm <sup>2</sup>	10,0
20	0,60mm <sup>2</sup>	13,0
18	1,00mm <sup>2</sup>	17,5
16	1,20mm <sup>2</sup>	20,0
14	2,00mm <sup>2</sup>	28,0
12	3,00mm <sup>2</sup>	37,0
10	4,50mm <sup>2</sup>	53,0
8	9,00mm <sup>2</sup>	78,0

**IMPORTANT!!**  
The minimal wire resistance of the wiring has to be taken into account...  
Attention: - all not marked wire are AWG28  
- small letters are underlined  
- IC / ring type  
- use ethernetable CAT5  
- fireproofable as spec. IEE1394  
- all CAN networks must be terminated with 120Ω at the end of each network  
- the CAN networks may extend to another harness, respect that the ends of the network have the termination resistor and that there are only 2 termination resistors for the entire network - resulting in a 60Ω network  
- order of devices within the CAN networks can be determined by the customer  
- please respect strictly the pairs while using datelines like USB or Ethernet  
- ethernet wires must be wired separately  
- wire diameter must be adapted depending on usage

Rev.	Description	Date	Author	Checked	Original language
01	Issue for production	20231018	Ku.BFH		BEGMSD-NA
02	Change of wire gauge	20231018	Ku.BFH		BEGMSD-NA
03	Change of wire gauge	20231018	Ku.BFH		BEGMSD-NA
04	Change of wire gauge	20231018	Ku.BFH		BEGMSD-NA
05	Change of wire gauge	20231018	Ku.BFH		BEGMSD-NA
06	Change of wire gauge	20231018	Ku.BFH		BEGMSD-NA
07	Change of wire gauge	20231018	Ku.BFH		BEGMSD-NA
08	Change of wire gauge	20231018	Ku.BFH		BEGMSD-NA
09	Change of wire gauge	20231018	Ku.BFH		BEGMSD-NA
10	Change of wire gauge	20231018	Ku.BFH		BEGMSD-NA
11	Change of wire gauge	20231018	Ku.BFH		BEGMSD-NA
12	Change of wire gauge	20231018	Ku.BFH		BEGMSD-NA
13	Change of wire gauge	20231018	Ku.BFH		BEGMSD-NA
14	Change of wire gauge	20231018	Ku.BFH		BEGMSD-NA
15	Change of wire gauge	20231018	Ku.BFH		BEGMSD-NA
16	Change of wire gauge	20231018	Ku.BFH		BEGMSD-NA
17	Change of wire gauge	20231018	Ku.BFH		BEGMSD-NA
18	Change of wire gauge	20231018	Ku.BFH		BEGMSD-NA
19	Change of wire gauge	20231018	Ku.BFH		BEGMSD-NA
20	Change of wire gauge	20231018	Ku.BFH		BEGMSD-NA
21	Change of wire gauge	20231018	Ku.BFH		BEGMSD-NA
22	Change of wire gauge	20231018	Ku.BFH		BEGMSD-NA
23	Change of wire gauge	20231018	Ku.BFH		BEGMSD-NA
24	Change of wire gauge	20231018	Ku.BFH		BEGMSD-NA

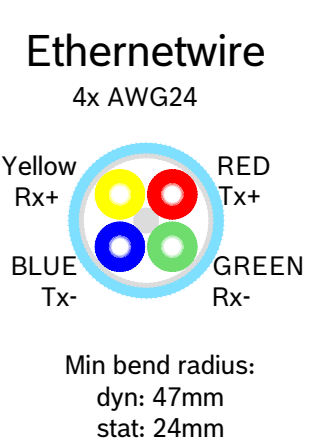

Bestell-Nummer order number	Entwurfszeichnung schematic	IMSA Scrutineering Loom	Benennung part name

Alle Rechte bei Robert Bosch GmbH, auch fuer den Fall von Schutzrechtsanmeldungen. Jede Verfertigungsbefugnis, wie Kopier- und Weitergaberecht, bei uns.

This drawing is the exclusive property of Robert Bosch GmbH. Without their consent it may not be reproduced or given to third parties.

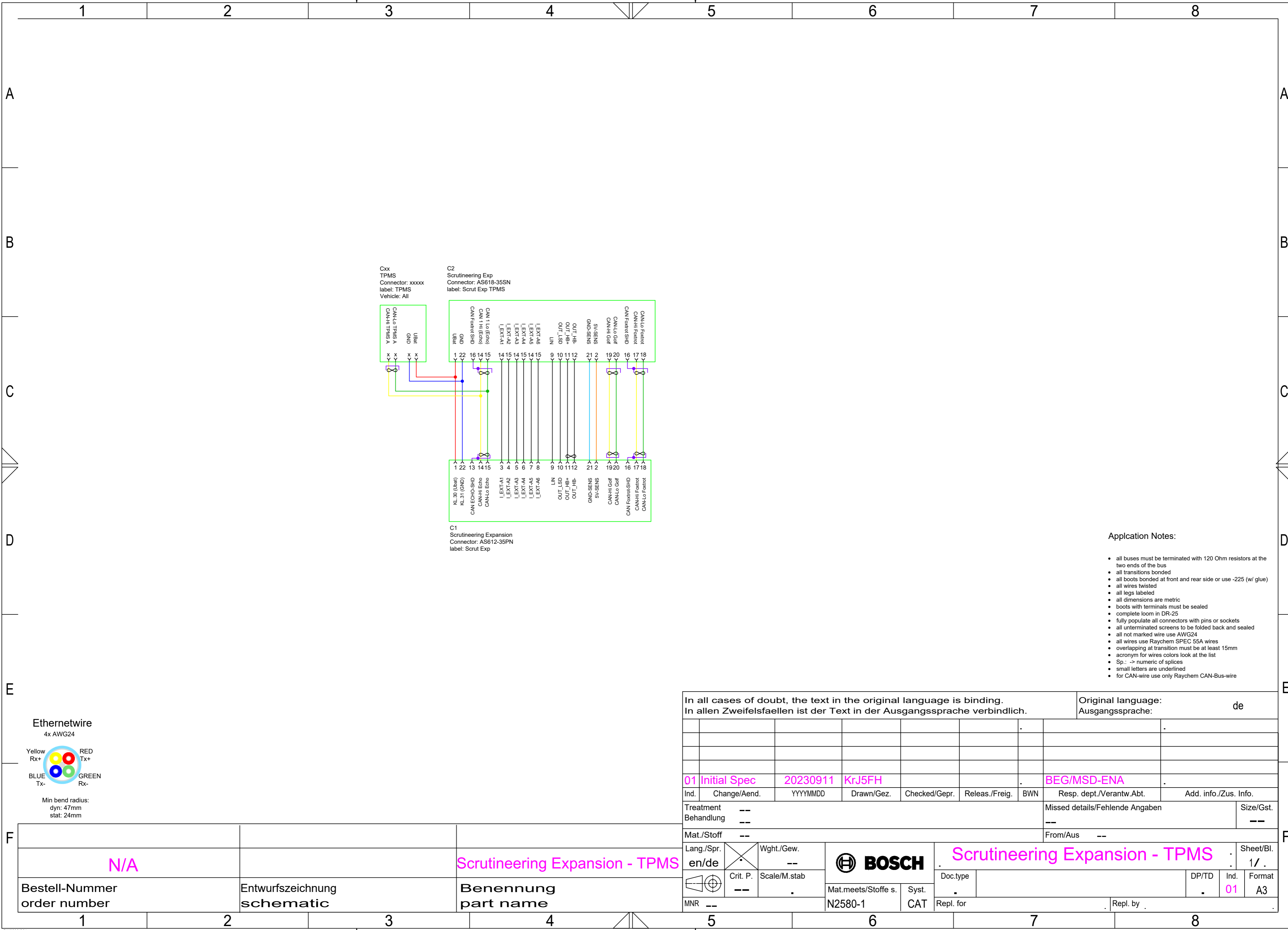

- Application Notes:**
- all buses must be terminated with 120 Ohm resistors at the two ends of the bus
  - all transitions bonded
  - all boots bonded at front and rear side or use -225 (w/ glue)
  - all wires twisted
  - all legs labeled
  - all dimensions are metric
  - boots with terminals must be sealed
  - complete loom in DR-25
  - fully populate all connectors with pins or sockets
  - all unterminated screens to be folded back and sealed
  - all not marked wire use AWG24
  - all wires use Raychem SPEC 55A wires
  - overlapping at transition must be at least 15mm
  - acronym for wires colors look at the list
  - Sp.: -> numeric of splices
  - small letters are underlined
  - for CAN-wire use only Raychem CAN-Bus-wire



In all cases of doubt, the text in the original language is binding. In allen Zweifelsfaellen ist der Text in der Ausgangssprache verbindlich.						Original language: de					
01 Initial Spec						20230911		KrJ5FH		BEG/MSD-ENA	
Ind.	Change/Aend.	YYYYMMDD	Drawn/Gez.	Checked/Gepr.	Releas./Freig.	BWN	Resp. dept./Verantw.Abt.	Add. info./Zus. Info.			
Treatment	Behandlung						Missed details/Fehlende Angaben			Size/Gst.	
Mat./Stoff	Lang./Spr.						From/Aus			---	
en/de		Wght./Gew.		Scale/M.stab		Doc.type		DP/TD		Ind. Format	
Crit. P.		Mat.meets/Stoffe s.		Syst.		Repl. for		01		A3	
MNR		N2580-1		CAT		Repl. by					

N/A		Scrutineering Expansion - TPMS	
Bestell-Nummer order number		Entwurfszeichnung schematic	
1		2	
3		4	
Benennung part name			

---

# 8 Appendix

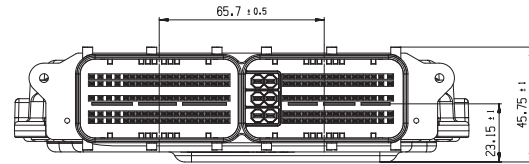

**MOUNTING IN VEHICLE:**  
Einbau im Fahrzeug:

THE CONTROL UNIT HAS TO BE FASTENED AT POSITIONS ①, ②, ③ AND ④.  
Das Steuergerät muss an den Stellen ①, ②, ③ und ④ befestigt sein.  
MAXIMUM SURFACE PRESSURE ALLOWED ON THE SCREW-ON SURFACES OF THE CONTROL UNIT: 140 N/mm<sup>2</sup>  
Maximal zulässige Flächenpressung an Anschraubflächen des Steuergerätes: 140 N/mm<sup>2</sup>

MAXIMUM TOLERANCE OF THE CUSTOMERS SCREW-ON SURFACES BETWEEN THE POSITIONS ①, ②, ③ AND ④:  $\square 0.5 \square$   
Zulässige Toleranz der kundenseitigen Anschraubflächen zwischen den Stellen ①, ②, ③ und ④:  $\square 0.5 \square$

IT HAS TO BE ASSURED THAT BOUNCING OF CONTROL UNIT OR POTENTIAL ADDITIONAL FASTENING ELEMENTS OF THE CONTROL UNIT CANNOT OCCUR DUE TO THE MOUNTING IN THE VEHICLE.  
Die Befestigung des Steuergerätes im Fahrzeug muss so ausgeführt werden, dass ein Prellen des Steuergerätes gegen andere Fahrzeugteile und eventuell zusätzliche Befestigungselemente des Steuergerätes ausgeschlossen ist.

IN CASE OF DEVIATIONS FROM THIS DRAWING, PERMITTED MECHANICAL INTERFACES TO VEHICLE AND RESULTANT LOAD ON COVER AND BOTTOM HAVE TO BE DISCUSSED WITH BOSCH ENGINEERING GMBH.  
Die zulässigen Schnittstellen zum Fahrzeug sowie die resultierenden Kräfte auf Deckel und Boden sind im Falle von Abweichungen von dieser Zeichnung mit Bosch Engineering GmbH abzustimmen.

MAXIMUM INTERNAL TEMPERATURE ACCORDING TO PROJECT-SPECIFIC USER MANUAL.  
Maximale Innentemperatur gemäss projektspezifischem Benutzerhandbuch.

PROTECTION AGAINST HUMIDITY ACCORDING TO PROJECT-SPECIFIC USER MANUAL.  
Schutz gegen Eindringen von Feuchtigkeit gemäss projektspezifischem Benutzerhandbuch.

IT HAS TO BE ASSURED THAT WATER CANNOT INFILTRATE INTO THE CONTROL UNIT THROUGH WIRING HARNESS IN MOUNTING POSITION.  
Es muss im Einbau sichergestellt sein, dass ueber den Leitungsstrang kein Wasser in das Steuergerät gelangen kann.

STANDING OR PERMANENTLY RUNNING WATER IS NOT PERMISSIBLE IN THE AREA OF CIRCUMFERENTIAL SEALING GROOVES, AS WELL AS IN THE AREA OF THE PRESSURE COMPENSATION ELEMENT. PERMITTED IMPACT OF WATER ACCORDING TO PROJECT-SPECIFIC USER MANUAL.  
Im Bereich der umlaufenden Dichtungsruten, sowie im Bereich des Druckausgleichselements ist kein stehendes oder permanent laufendes Wasser zulässig. Zulässige Wasserbeaufschlagung gemäss projektspezifischem Benutzerhandbuch.

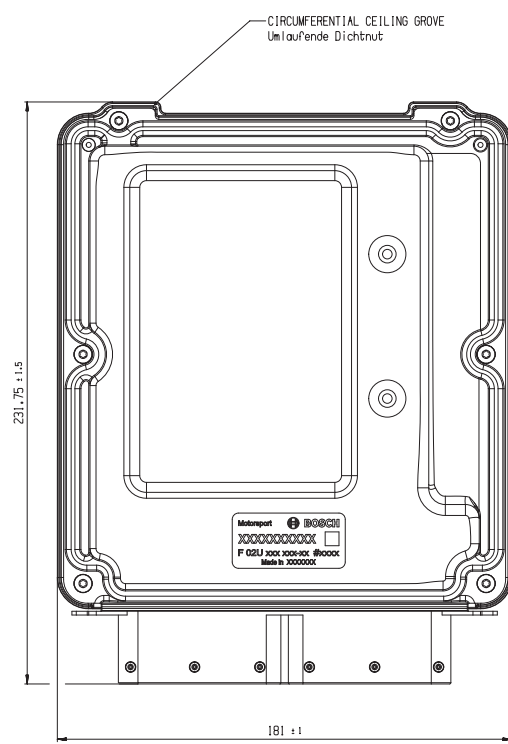
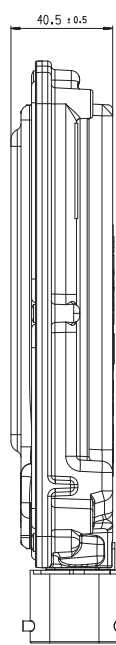
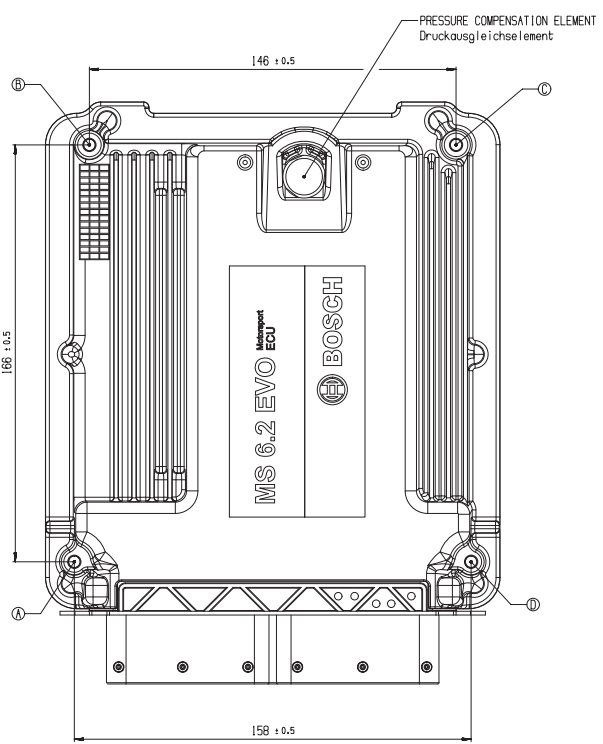
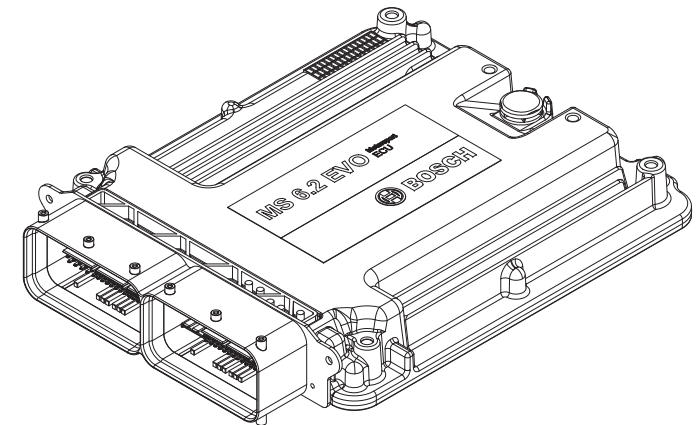

**GENERAL DESCRIPTIONS AND REFERENCES FOR THE DRAWING:**  
Allgemeine Angaben und Hinweise zur Zeichnung:

THE CONTROL UNIT CAN DEViate FROM THIS DRAWING IN NOT DIMENSIONED NON-FUNCTIONAL GEOMETRIES. Das Steuergerät kann in unbemasteten nicht funktionsrelevanten Geometrien von der Darstellung in dieser Zeichnung abweichen.

PERMITTED APPLICATION AREA: ACCORDING TO ENVIRONMENTAL CONDITIONS SPECIFIED IN PROJECT-SPECIFIC USER MANUAL. Zulässiger Einsatzbereich: Gemäss der im projektspezifischem Benutzerhandbuch definierten Umweltbedingungen.

**WIRING HARNESS PLUG:**  
Kabelbaumstecker:

THE WIRING HARNESS PLUG IS NOT INCLUDED IN DELIVERY. Der Kabelbaumstecker gehoert nicht zum Lieferumfang.

IT HAS TO BE ASSURED THAT DUE TO MECHANICAL FIXATION THE EXCITATION OF THE WIRING HARNESS IS IN THE SAME SEQUENCE AS THE CONTROL UNIT. Kabelbaue sind im Bereich der Anbaustelle des Steuergerätes mechanisch so abzufangen, dass eine phasengleiche Anregung zu dem Steuergerätes erfolgt.

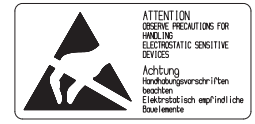

ORDER NUMBER: Motorport **BOSCH** MS 6.2 EVO  
CONSECUTIVE PART NUMBER: F 02U V03 115-01  
Part/Laufende Teilenummer: Motorport **BOSCH** MS 6.2 EVO  
Made in Germany

CUSTOMER NUMBER		CATALOGUE PRODUCT		General tolerances for dimensions unless otherwise specified		
Order number	Part number	Part name	Part description	mm	mm	mm
F 02U V03 115-01	F 02U V03 115-01	CONTROL UNIT	STEUERGERAET	± 0.1	± 0.1	± 0.1
01 F02U025217	20210303	REBILLO				
02			672	RES/MSD		
03						
04						
05						
06						
07						
08						
09						
10						
11						
12						
13						
14						
15						
16						

## VMPS Dimensions

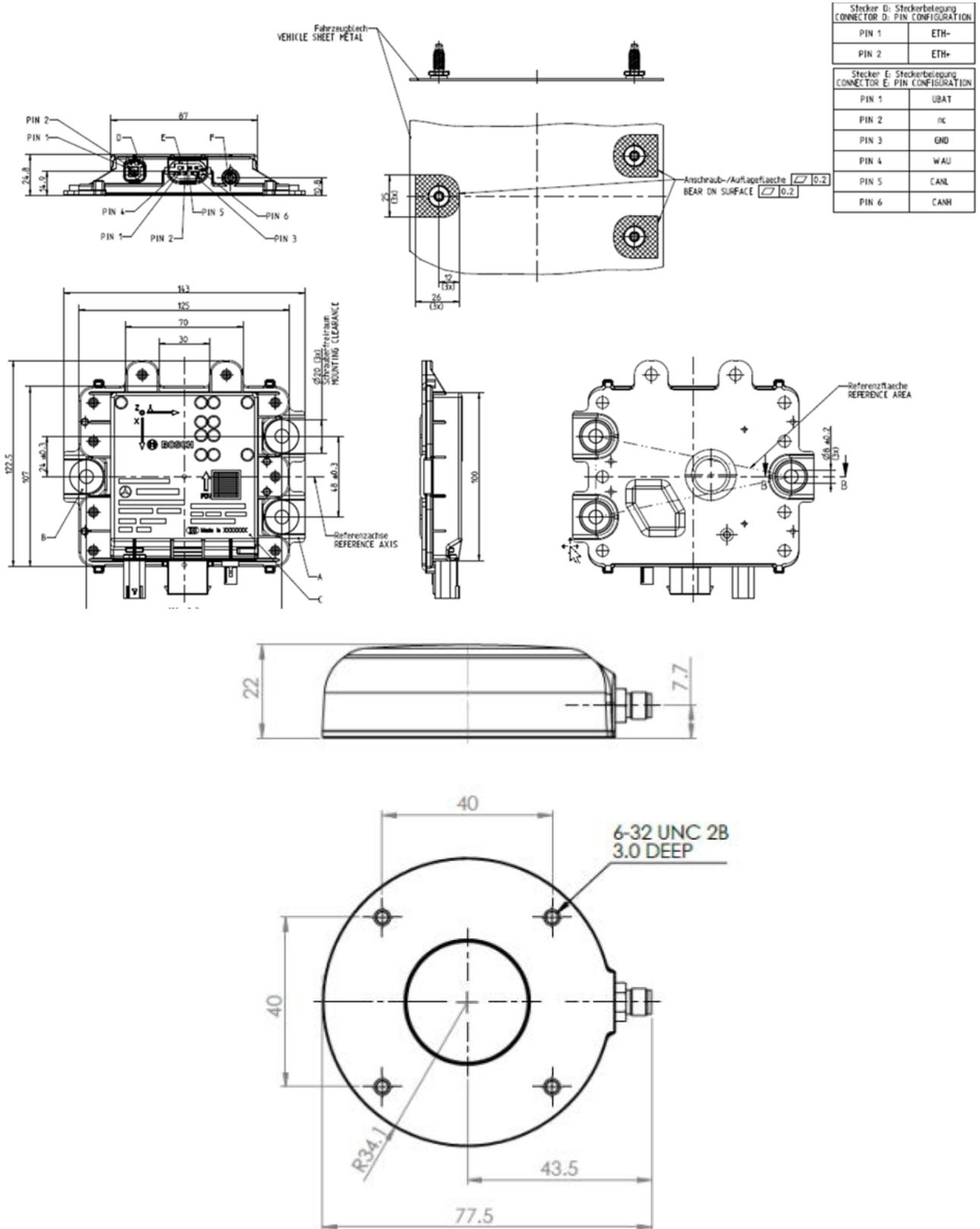

GENERAL DESCRIPTIONS AND REFERENCES FOR THE DRAWING:  
Allgemeine Angaben und Hinweise zur Zeichnung:

CONTROL UNIT (CU) CAN DEVIATE FROM THIS DRAWN CONSTRUCTION IN NOT DIMENSIONED NON-FUNCTIONAL GEOMETRIES.  
Elektronisches Steuergeraet (SG) kann in unbemasteten nicht funktionsrelevanten Geometrien von der Darstellung in dieser Zeichnung abweichen.

IT HAS TO BE ASSURED IN MOUNTING POSITION THAT WATER CANNOT INFILTRATE THROUGH WIRING HARNESS INTO THE CU.  
Es muss im Einbau sichergestellt sein, dass ueber den Leitungsstrang kein Wasser in das SG gelangen kann.

IT HAS TO BE ASSURED IN MOUNTING POSITION THAT THE PRESSURE COMPENSATION ELEMENT AND THE SEALING IN THE REVOLVING GROOVE DO NOT GET SUBMERGED IN WATER.  
Es muss im Einbau sichergestellt sein, dass das DAE und die Dichtung im umlaufenden Nutbereich nicht in Wasser getaucht werden.

CU FULFILLS REQUIREMENTS ACCORDING TO PROJECT SPECIFIC TCD.  
PERMITTED APPLICATION AREA: ACCORDING TO ENVIRONMENTAL CONDITIONS SPECIFIED IN PROJECT SPECIFIC TCD.  
PERMITTED MOUNTING LOCATION: CHASSIS AND ENGINE COMPARTMENT, SO THAT THE ENVIRONMENTAL CONDITIONS SPECIFIED IN PROJECT SPECIFIC TCD ARE COMPLIED WITH.  
SG erfuellt Anforderungen nach projektspezifischer TKU.  
Zulaessiger Einsatzbereich: Gemass der in projektspezifischer TKU definierten Umweltbedingungen.  
Zulaessiger Anbauort: Karosserie und Motorraum, so dass die in der projektspezifischen TKU beschriebenen Umweltbedingungen eingehalten werden.

MOUNTING CU IN VEHICLE:  
Einbau SG im Fahrzeug:

THE FASTENING OF THE CU IN THE VEHICLE HAS TO BE DESIGNED IN A WAY THAT BOUNCING OF CU AGAINST OTHER VEHICLE PARTS AND EVENTUALLY ADDITIONAL FASTENING ELEMENTS OF THE CU CANNOT OCCUR.  
Die Befestigung des SG im Fahrzeug muss so ausgefuehrt werden, dass ein Prellen des SG gegen andere Fahrzeugteile und eventuell zusaetzliche Befestigungselemente des SG ausgeschlossen ist.

WIRING HARNESS PLUG:  
Kabelbaumstecker:

THE WIRING HARNESS PLUG IS NOT INCLUDED IN DELIVERY.  
Der Kabelbaumstecker gehoert nicht zum Lieferumfang:

WIRING HARNESS NEEDS TO BE FIXED MECHANICALLY AT THE AREA OF CU IN A WAY THAT EXCITATION OF CU HAS THE SAME SEQUENCE.  
Kabelbaeume sind im Bereich der Anbaustelle des SG mechanisch so abzufangen, dass eine phasengleiche Anregung des SG erfolgt.

MAXIMUM INTERNAL TEMPERATURE ACCORDING TCD  
WATER PROTECTION ACCORDING TCD  
Maximale Innentemperatur gemass projektspezifischer TKU  
Eigenschaft gegen Eindringen von Feuchtigkeit gemass projektspezifischer TKU

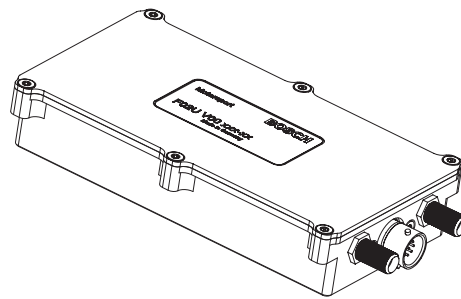
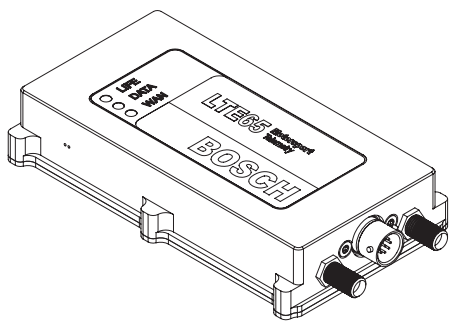
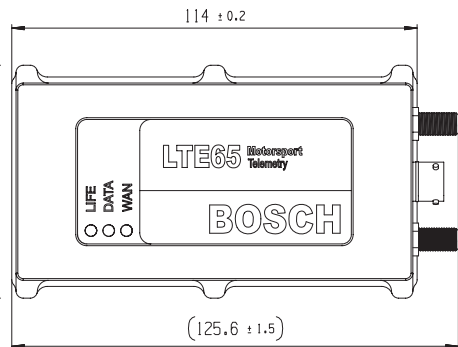
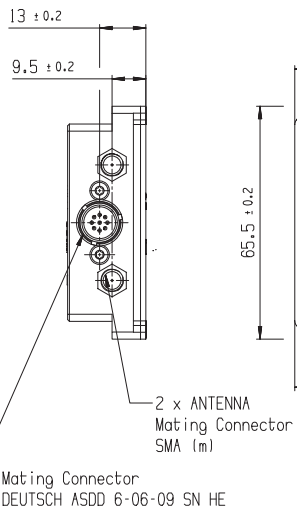
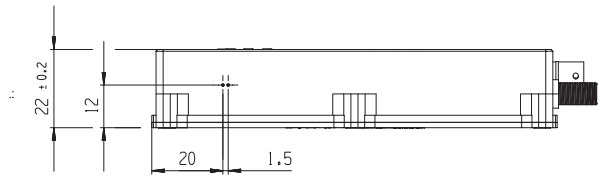

general tolerances for/Allgemeintoleranzen fuer			
lin. dim./L-masse	radII/Radien	angles/Winkel	
±[mm]	±[mm]	±[°]	
all linear dimensions in/ Alle Längenmassen in			
mm			
Size acc. to / Masse nach			
ISO 14405-1:2010-12			
envelope principle/ Huellprinzip			Ⓔ

ORDER NUMBER Bestellnummer		F 02U V03 042-01			
01	F02UC05156	20201104	rebllo	6720	BEG/MSD
Incl.	Change/Änd.	YYYYMMDD	Drawn/Bez.	Checked/Gepr.	Released/Freig.
Lang./Spr.	Syst.	Right./Recht.	en/de	UG	120 g
Scale/N.stab		1:1			
OFFER DRAWING ANGEBOTSZEICHN.		CONTROL UNIT STEUERGERAET		LTE65 EMEA LTE65 EMEA	
Repl. for		Doc. type		F 02U A03 042-01	
Repl. by		UP/ID		000 01	
		Ind.		Formst.	
				AZ	

© Bosch Engineering GmbH. All rights reserved. Also regarding the use of the drawings. Further information for industrial property rights.

© Bosch Engineering GmbH. All rights reserved. Also regarding the use of the drawings. Further information for industrial property rights.

FIGUANG34237 AGZ 000 01 STEUERGERAET LTE65 JP

© Bosch Engineering GmbH. All rights reserved, also regarding any dissemination, reproduction, editing, distribution, as well as in the event of applications for industrial property rights.

© Bosch Engineering GmbH. All rights reserved, also regarding any dissemination, reproduction, editing, distribution, as well as in the event of applications for industrial property rights.

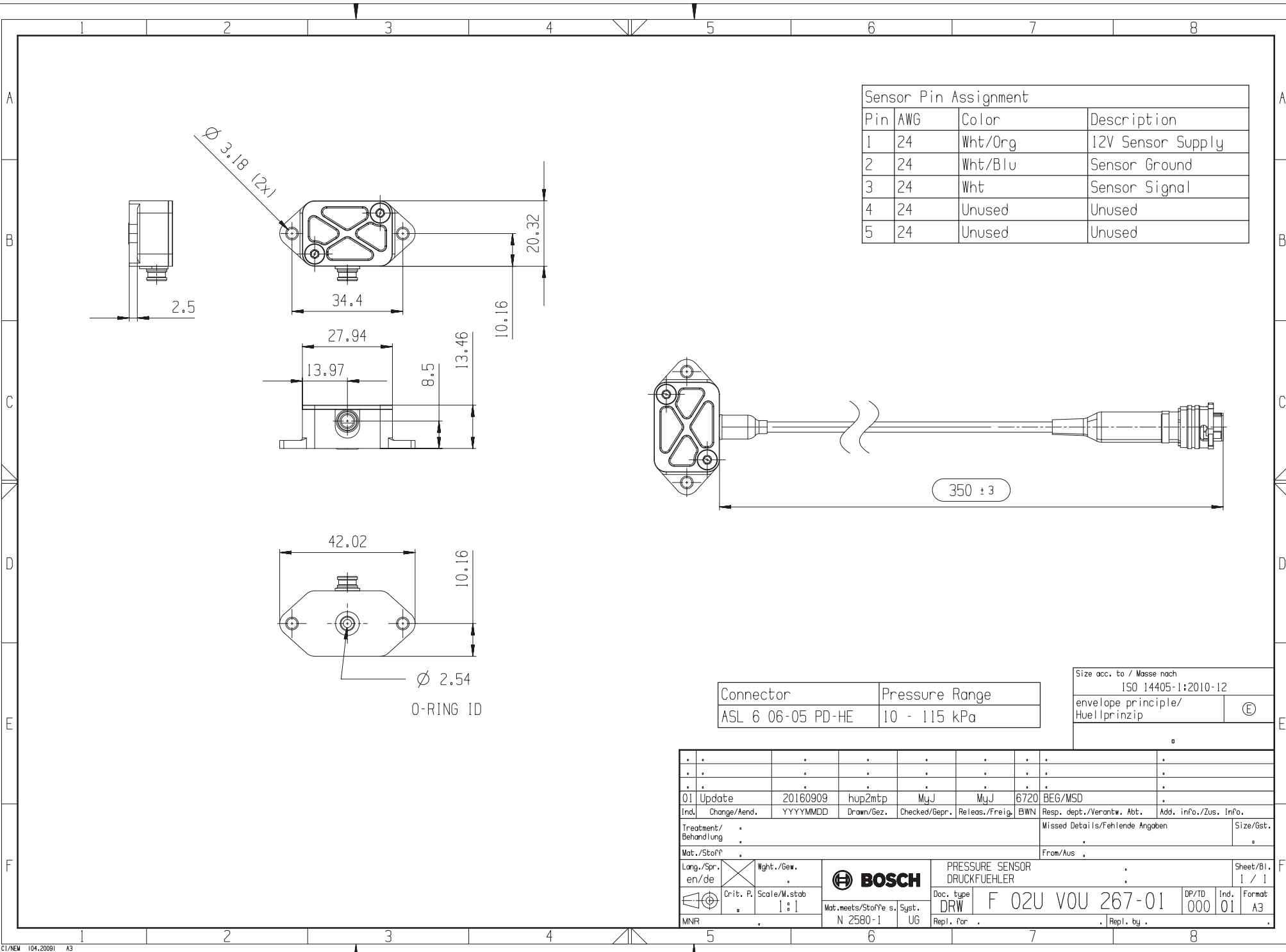

Sensor Pin Assignment			
Pin	AWG	Color	Description
1	24	Wht/Org	12V Sensor Supply
2	24	Wht/Blu	Sensor Ground
3	24	Wht	Sensor Signal
4	24	Unused	Unused
5	24	Unused	Unused

Connector	Pressure Range
ASL 6 06-05 PD-HE	10 - 115 kPa

Size acc. to / Masse nach	
ISO 14405-1:2010-12	
envelope principle/ Huellprinzip	(E)

01 Update	20160909	hup2mtp	MjJ	MjJ	6720	BEG/MSD		
Ind. Change/Änd.	YYYYMMDD	Drawn/Gez.	Checked/Gepr.	Released/Freig.	BWN	Resp. dept./Verantw. Abt.	Add. info./Zus. Info.	
Treatment/ Behandlung						Missed Details/Fehlende Angaben	Size/Gst.	
Mat./Stoff						From/Aus		
Lang./Spr. en/de	Wght./Gew.	<b>BOSCH</b>				PRESSURE SENSOR DRUCKFUEHLER		Sheet/Bl. 1 / 1
Crit. P.	Scale/M.stab					Doc. type DRW	F 02U VOU 267-01	DP/TO 000
MNR	Mat.meets/Stoffe s.	Syst. UG	Repl. for	Repl. by				

© Bosch Engineering GmbH. Alle Rechte vorbehalten, auch bzgl. jeder Vervielfältigung, Verbreitung, Reproduktion, Bearbeitung, Weitergabe sowie für den Fall von Schutzrechtsanmeldungen.

© Bosch Engineering GmbH. All rights reserved, also regarding any disposal, exploitation, reproduction, editing, distribution, as well as in the event of applications for industrial property rights.

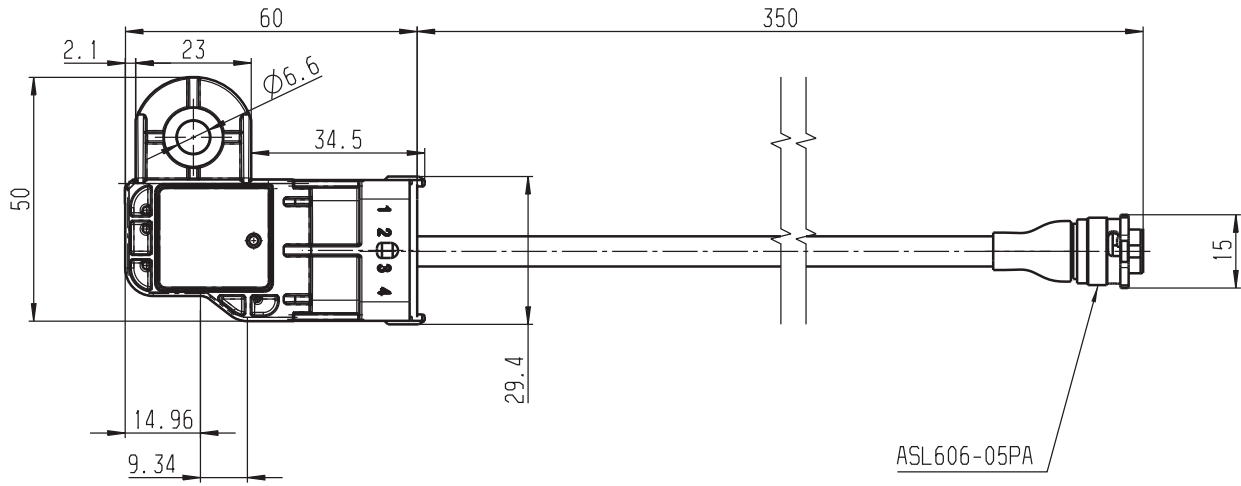

Pin Out	
1	Sens 5v
2	Sens GND
3	Signal
4	N-C
5	N-C

Matting Connector:  
ASL106-05SA

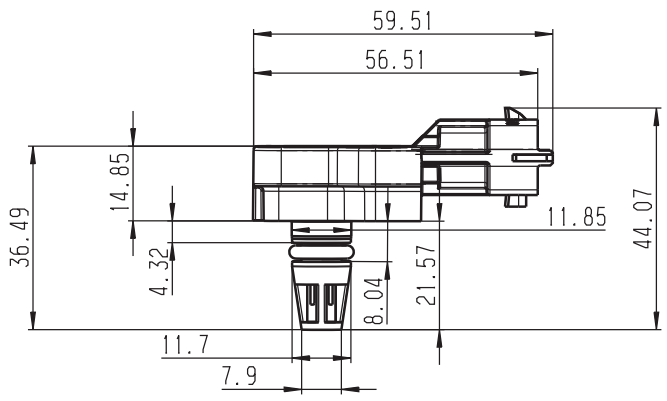

Sensor

**Mounting Instructions:**

- Recommended position: 0...±60° in all directions from vertical; orifice facing downwards
- Sensor should be mounted on a flat surface, with the base of the sensor sufficiently supported
- Mounting screw: M6x1
- Installation torque: 3.3 Nm

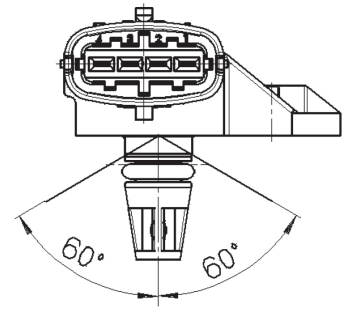
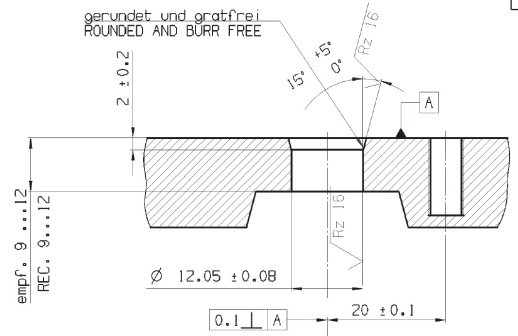

02	Mounting	20151203	Brk	BeJ	OhE	MSD	BEG/MSD-NA	
01	Initial	20151106	Brk	OhE	OhE	MSD	BEG/MSD-NA	
Ind.	Change/Änderung	YYYYMMDD	Drawn/Gez.	Checked/Gepr.	Released/freig.	BWN	Resp. dept./Verantw. Abt.	Add. info./Zus. Info.
Lang./Spr.	Syst.	Wght./Gew.				Pressure Sensor: 1 Bar - IMSA		Sheet/Bl.
en/de	CAT	--				1/1		
	Scale/M. stab	NTS	OFFER DRAWING ANGEBOTSZEICHN.			Doc. type	F02U.VOU.204-01	DP/TD
MNR	--					Repl. for		Repl. by

© Bosch Engineering GmbH. Alle Rechte vorbehalten, auch bzgl. jeder Vervielfältigung, Verbreitung, Reproduktion, Bearbeitung, Weitergabe sowie für den Fall von Schutzrechtsanmeldungen.

© Bosch Engineering GmbH. All rights reserved, also regarding any disposal, exploitation, reproduction, editing, distribution, as well as in the event of applications for industrial property rights.

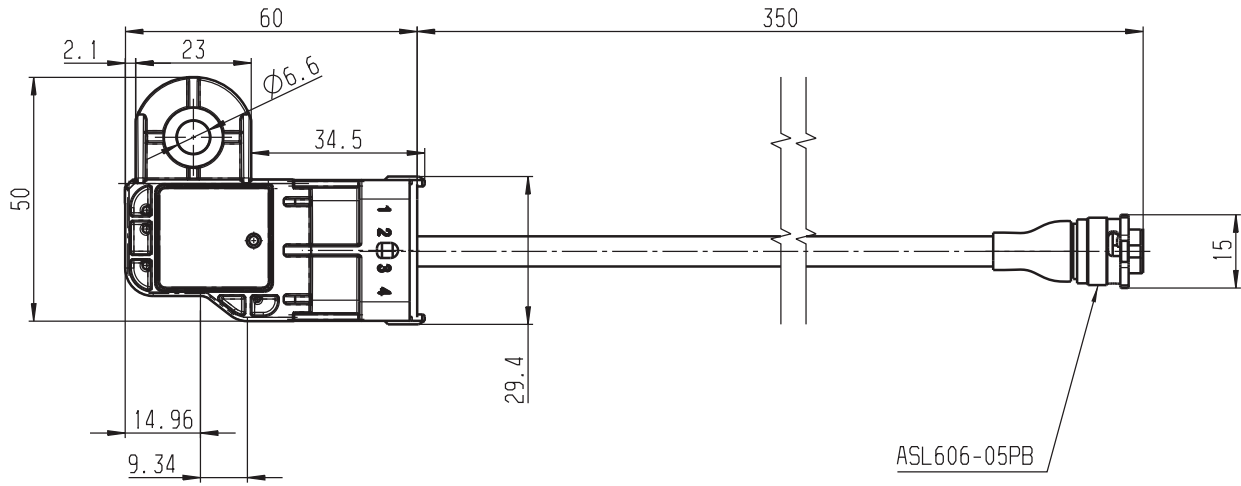

Pin Out	
1	Sens 5v
2	Sens GND
3	Signal
4	N-C
5	N-C

Mating Connector:  
ASL106-05SB

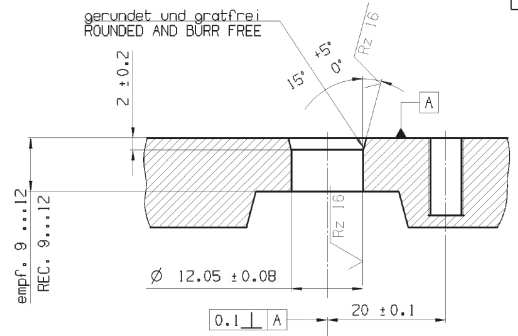
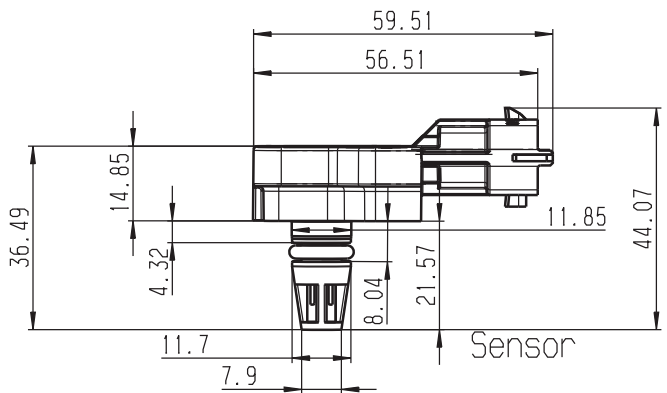

**Mounting Instructions:**

- Recommended position: 0...±60° in all directions from vertical; orifice facing downwards
- Sensor should be mounted on a flat surface, with the base of the sensor sufficiently supported
- Mounting screw: M6x1
- Installation torque: 3.3 Nm

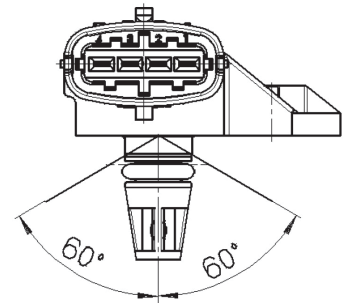

02	Mounting	20151203	Brk	BeJ	OhE	MSD	BEG/MSD-NA	
01	Initial	20151106	Brk	OhE	OhE	MSD	BEG/MSD-NA	
Ind.	Change/Änderung	YYYYMMDD	Drawn/Gez.	Checked/Gepr.	Released/freig.	BWN	Resp. dept./Verantw. Abt.	Add. info./Zus. Info.
Lang./Spr.	Syst.	Wght./Gew.				Pressure Sensor: Boost-IMSA		Sheet/Bl.
en/de	CAT	--				OFFER DRAWING ANGEBOOTSZEICHN.		F02U.V0U.205-01
Scale/M.stab	NTS		Repl. for		Repl. by		Format	
MNR	--						A3	

© Bosch Engineering GmbH. Alle Rechte vorbehalten, auch bzgl. jeder Vervielfältigung, Verbreitung, Reproduktion, Bearbeitung, Weitergabe sowie für den Fall von Schutzrechtsanmeldungen.

© Bosch Engineering GmbH. All rights reserved, also regarding any disposal, exploitation, reproduction, editing, distribution, as well as in the event of applications for industrial property rights.

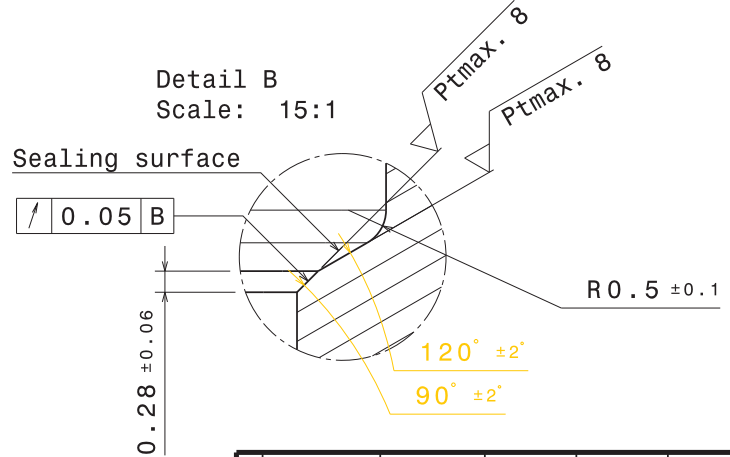
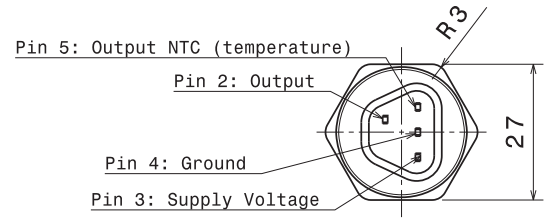
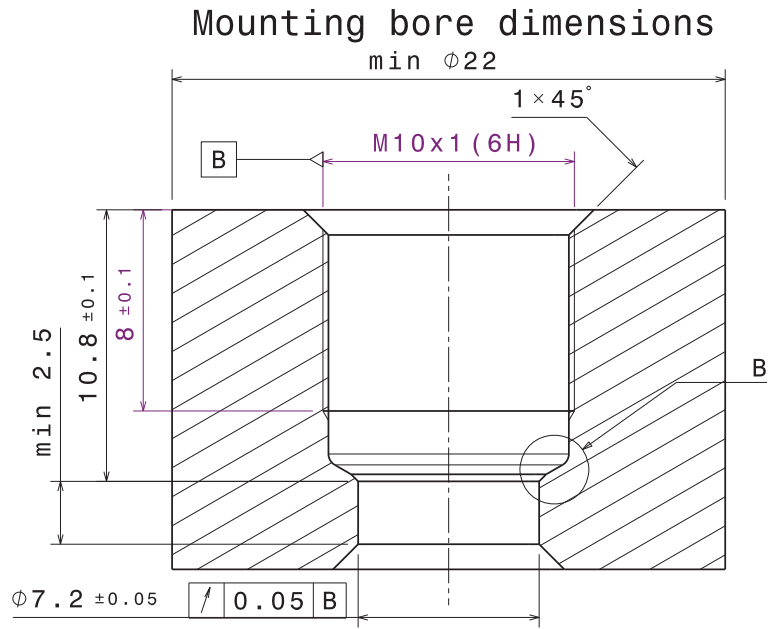
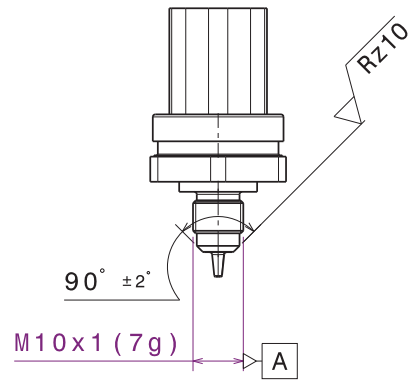
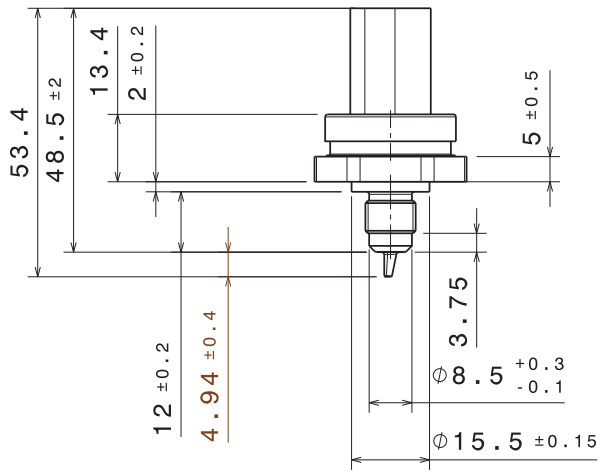

Mounting notes:  
 - Tightening torque: 37.5 NM (+/- 2.5 NM)  
 - Lubrication required for thread surfaces, avoid allowing lubricant in pressure port  
 - No contamination of surface sealing area allowed

General tolerances for/Allgemeintoleranzen fuer		
lin. dim./L.masse	radii/Radien	angles/Winkel
+/- 1 mm	+/- 1 mm	+/- 5 deg.
Size acc. to/Masse nach		
ISO 14405-1:2010-12		
envelope principle		(E)

Order Number	Temperature Range	Pressure Range
F02U.V0U.194-01	-40 - +140 deg. C	0-1000 kPa (rel.)

01 Initial	20160316	JnP	MSD2BEG/MSD2-NA			
Ind. Change/Änd.	YYYYMMDD	Drawn/Gez.	Checked/Gepr.	Releas./freig.	EWN Resp. dept./Verantw. Abt.	Ädd. info./Zus. Info.
Lang./Spr.	Syst.	Wght./Gew.	Pressure Sensor			Sheet/Bl.
en/de	CAT		Druckfuehler			1/1
Scale/M.stab	1:1		OFFER DRAWING			DP/TO
MNR			AGZ F02U.V0U.194-01			000 01
			Repl. for			Repl. by

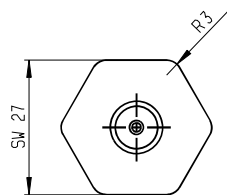

Front view  
Scale: 1:1

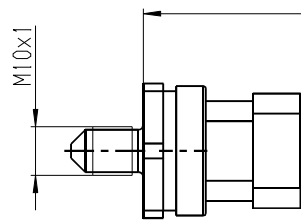

Connector View  
View A

Front view  
Scale: 1:1

ASL 6-06-05PC-HE

Installation torque in aluminium: 22Nm ±2Nm  
Installation torque in steel: 32.5Nm ±2.5Nm

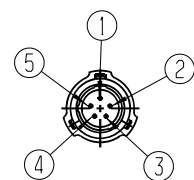
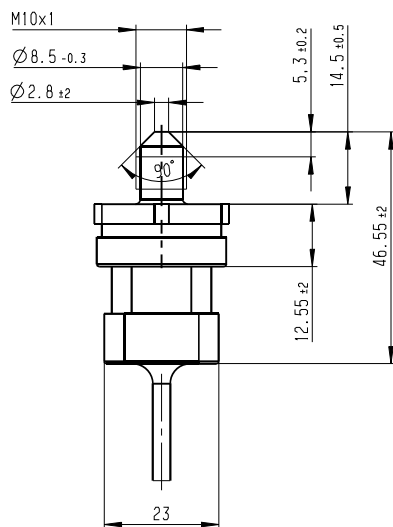

ASL 6-06-05PC-HE

- Pin 1: free
- Pin 2: GND
- Pin 3: SIG
- Pin 4: Power Supply 5V
- Pin 5: free

Vorschlag Montagebohrung  
RECOMMENDATION MOUNTING BORE

Vorschlag Montagebohrung in Stahl  
RECOMMENDATION MOUNTING BORE INTO STEEL

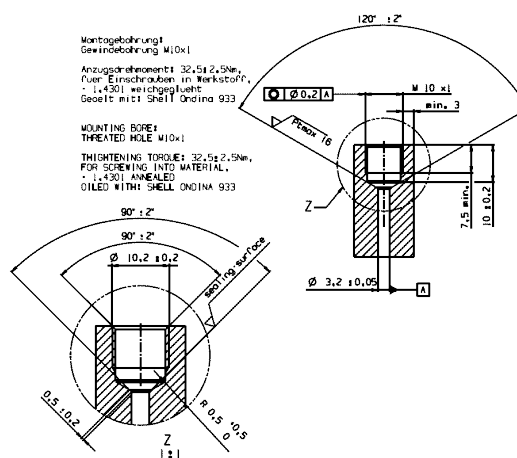

Vorschlag Montagebohrung in Aluminium  
RECOMMENDATION MOUNTING BORE INTO ALUMINIUM

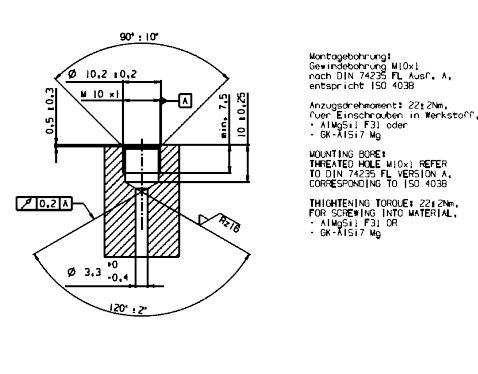

01 Erstellung	20110215	FzF	FzF			BEG/MSD4 WzP	
Ind. Change/Änderung	YYYYMMDD	Drawn/Gez.	Checked/Gepr.	Releas./Freig.	BWN	Resp. dept./Verantw. Abt.	Add. info./Zus. Info.
Leng./Spr. en/de	Syst. CAT	Wght./Gew. --					Sheet/Bl. 1/1
		Scale/M. stab 1:1					
			AGZ-A3 Pressure Sensor Fluid PSC-260				
OFFER DRAWING ANGEBOOTSZEICHN.			Doc. type F02U V00 990-02			DP/TD Ind. Format A3	
MNR --			Repl. for		Repl. by		

F 02U V00 990-02	500	ASL 6-06-05PC-HE	0 ... 260
Bestell-Nr. Order-no.	L-Länge [mm] Lenght [mm]	Stecker Connector	Messbereich [bar] Measur. Range [bar]

0 261 A04 407

Kabelbaumstecker: RB-Kompaktstecker 1.1a nach RB-Zeichnung  
A 928 000 453, 3-polig, Kodierung 1, BDK-Kontakte vergoldet,  
0,5-1,0mm<sup>2</sup>

Am Sensor: RB-Kompaktstecker 1.1 nach RB-Zeichnung  
1 928 A00 755 Variante B vom 11.05.2004 (in hochschuettelfester Ausführung)  
3-polig, Kodierung 1, Kontakte vergoldet  
Werkstoff: PBT GF30

WIRE HARNESS CONNECTOR: RB KOMPAKT CONECON 1.1A  
ACC. TO RB DRAWING A 928 000 453, 3 PINS, CODING 1.  
BDK TRMINALS GOLD-PLATED, 0,5-1,0 mm<sup>2</sup>

AT SENSOR: RB KOMPAKT CONNECTOR 1.1 ACC. TO RB DRAWING  
1 928 A00 755 VARIANT B FROM 11.05.2004 (IN HIGH VIBRATION RESISTANT DESIGN)  
3 PINS, CODING 1, TERMINALS GOLD-PLATED  
MATERIAL: PBT GF30

Pin 3: Versorgung (+)  
Pin 3: SUPPLY VOLTAGE (+)

Pin 2: Ausgang  
Pin 2: OUTPUT

Pin 1: Masse (-)  
Pin 1: GROUND (-)

Werkstoff: 1.4542 (DIN Norm)  
MATERIAL: 1.4542 (DIN Norm)

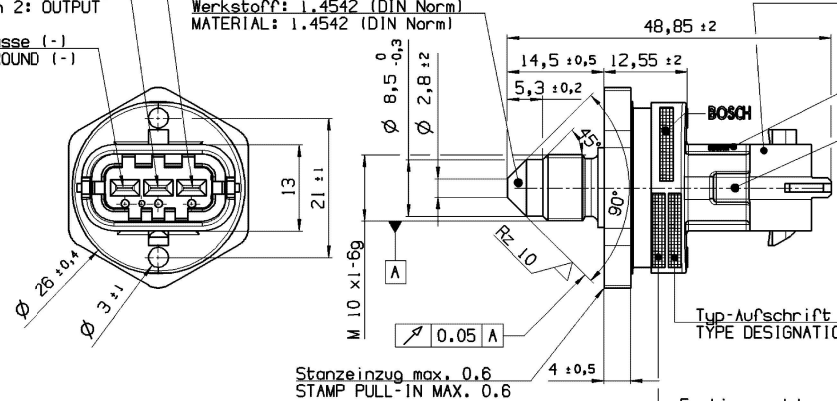

Herkuftsbezeichnung  
MARKING OF ORIGIN  
Auf der Rueckseite:  
ON THE BACK:



Werknummer  
NUMBER OF PLANT

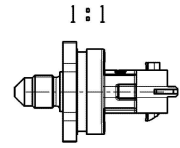
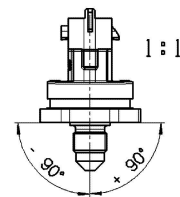
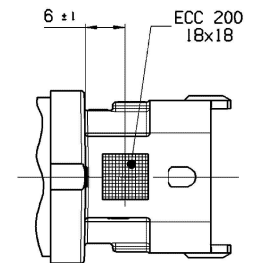
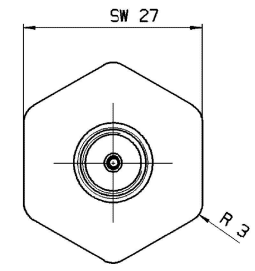

**Wichtige Hinweise:**

- RB-Gewaehrleistung fuer die Funktion des Stecksystems nur bei Verwendung der in dieser Angebotszeichnung vorgeschriebenen Gegenstecker-Systemteile.
- Erste Abstuetzstelle des Kabels max. 150mm nach der Steckverbindung (gestreckte Kabellaenge). Sie muss auf dem Sensortraeger liegen.
- Abwicklung des Kabels (Abweichung von der geraden Linie) zwischen Kabelabgang am Sensor und erster Abstuetzstelle: 20...90°
- Zulaessiger Biegeradius des Kabels bis zur ersten Abstuetzstelle: R ≥ 50mm
- Einbauvorschrift siehe zugehoerige Railangebotszeichnung bzw. Rail-TKU
- Max. zulassige Einschraubbelastung: 35Nm
- Montagehinweis siehe Y 261 F26 048

Zu beachten: Sensor ist durch aufgesteckten Gegenstecker vor Eindringen von Wasser zu schuetzen.

**IMPORTANT NOTES**

- RB WARRANTY WILL COVER THE FUNCTION OF THE CONNECTOR SYSTEM ONLY IN CASE OF COMBINATION WITH HARNESS CONNECTOR SYSTEM PARTS ACCORDING TO THIS OFFER DRAWING.
- FIRST CABLE MOUNTING POINT MAX. 150 MM AFTER THE PLUG (STRAIGHT CABLE LENGTH). IT MUST BE LOCATED ON THE SENSOR CARRIER.
- ANGLE OF BENDING THE CABLE (DEVIATION FROM STRAIGHT LINE) BETWEEN CABLE EXIT AT SENSOR AND FIRST MOUNTING POINT: 20...90°
- ADMISSIBLE BENDING RADIUS OF THE CABLE UP TO THE FIRST CABLE MOUNTING POINT: R ≥ 50MM.
- INSTALLATION INSTRUCTIONS SEE CORRESPONDING OFFER DRAWING RAIL RESPECTIVELY TKU RAIL
- MAX. AUTHORIZED STRESS TO SCREW IN: 35Nm
- ASSEMBLY INSTRUCTIONS SEE Y 61 F26 048

ATTENTION: USE HARNESS CONNECTOR FOR PROTECTION AGAINST WATER INGRESS.

Stuetzen nach unten gerichtet.

Empfohlene Lage: 0...90°  
in allen Richtungen zur Senkrechten.

ORIFICE DIRECTED DOWNWARDS.

RECOMMENDED POSITION: 0...90°  
FROM VERTICAL.

Nicht-tol.-Masse NON TOLERANCED DIMENSIONS ±1 mm, ±5 °		ISO E	Massstab SCALE	2:1	1:1	Gewicht WEIGHT	35,3 g
Dokumentart/ DOCUMENT TYPE		AGZ	Angebots- zeichnung		OFFER DRAWING		
Gr.-St. VOLUME		Datum/ DATE		Name/ NAME		Benennung/ TITLE	
1		14.12.2005		De		RAIL PRESSURE SENSOR	
Original: GS-SI/ENS		DS-HD-KV4.2. 26 MPa					
DIN A2		20.12.2007		Kr		Blatt SHEET 1	
0 261 545 040		De		0 261 A04 407		de/en	
N <sup>o</sup> / NO.		0 261 545 040		0 261 A04 407		1 Bl./9	
Aenderung CHANGE		ges. ISS.		gueltig VALID		gep. CHK.	
Ers./ REPLACES		Ers./ REPLACES					

© Alle Rechte bei Robert Bosch GmbH, auch fuer den Weiterverkauf. Nachdruck, Verbreitung oder sonstiger Gebrauch, wie Kopieren, ist ohne schriftliche Genehmigung von Robert Bosch GmbH. NOT BE REPRODUCED OR TRANSMITTED IN ANY FORM OR BY ANY MEANS, ELECTRONIC OR MECHANICAL, INCLUDING PHOTOCOPYING, RECORDING, OR BY ANY INFORMATION STORAGE AND RETRIEVAL SYSTEM.

OBSERVE INSTRUCTIONS FOR FILLING OUT N12A D11/L1 beachten!

© Bosch Engineering GmbH. Alle Rechte vorbehalten, auch bzgl. jeder Verfügung, Vervielfältigung, Reproduktion, Bearbeitung, Weitergabe sowie für den Fall von Schutzrechtsansprüchen.

© Bosch Engineering GmbH. All rights reserved, also regarding any disposal, exploitation, reproduction, editing, distribution, as well as in the event of applications for industrial property rights.

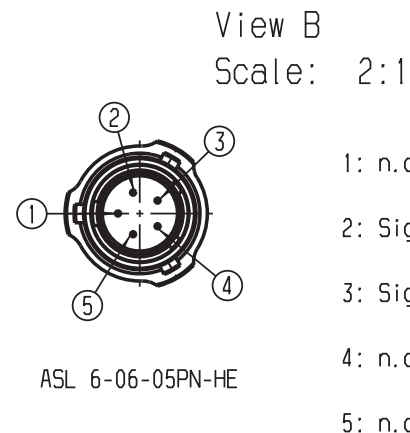
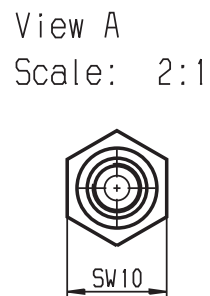
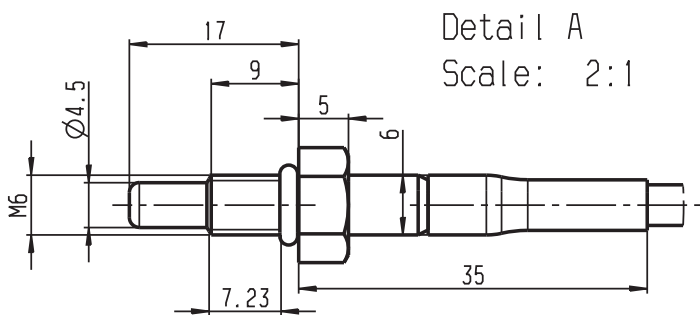

Installation  
Recommendation  
Scale: 3:1

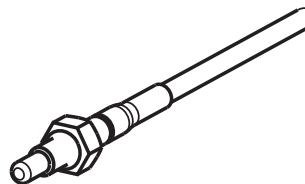
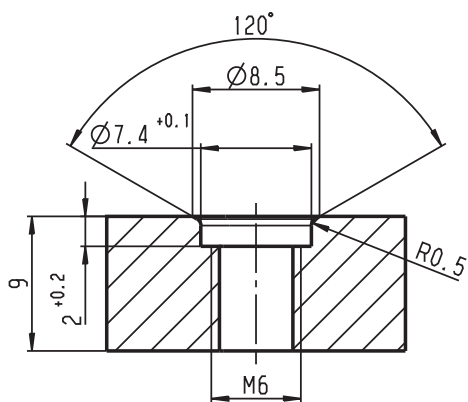
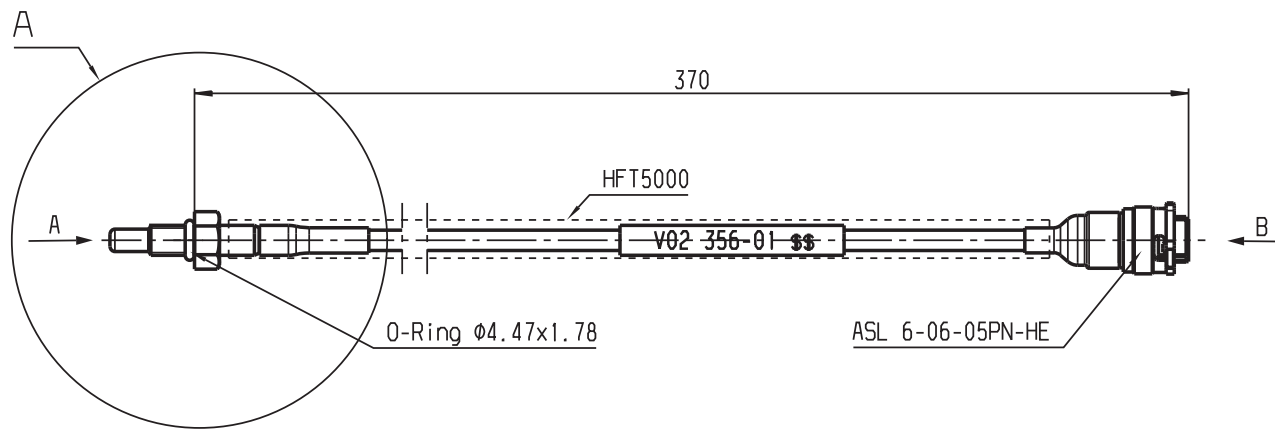

general tolerances for/Allgemeintoleranzen fuer		
lin. dim./L. Masse	radii/Radien	angles/Winkel
± 1	± 0.5	± 2°
size acc. to/Masse nach ISO 14405-1:2010-12		
envelope principle / Huellprinzip		(E)

F 02U V02 356-01 DH	-55...300
Order Number Bestellnummer	Temperature Range [°C] Temperaturbereich [°C]

01 Erstellung	20151126	SKR	672	BEG/MSD-P Behrens
Ind. Change/Änd.	YYYYMMDD	Drawn/Gez.	Checked/Gepr.	Releas./Freig.
Lang./Spr.	Syst.	Wght./Gew.	Temperature Sensor NTC-M6HS	
en/de	CAT	--	Temperatursensor NTC-M6HS	
Scale/M.stab		1:1	Doc. type	
MNR		--	AGZ	F 02U V02 356-01
OFFER DRAWING ANGEBOTSZEICHN.			DP/TD	Ind. Format
Repl. for				A3
Repl. by				

© Bosch Engineering GmbH. Alle Rechte vorbehalten, auch bzgl. jeder Vervielfältigung, Verbreitung, Reproduktion, Bearbeitung, Weitergabe sowie für den Fall von Schutzrechtsanmeldungen.

© Bosch Engineering GmbH. All rights reserved, also regarding any disposal, exploitation, reproduction, editing, distribution, as well as in the event of applications for industrial property rights.

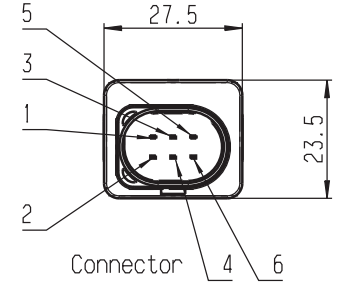
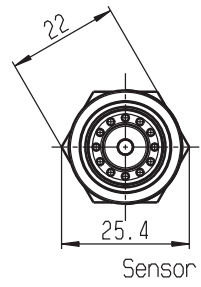
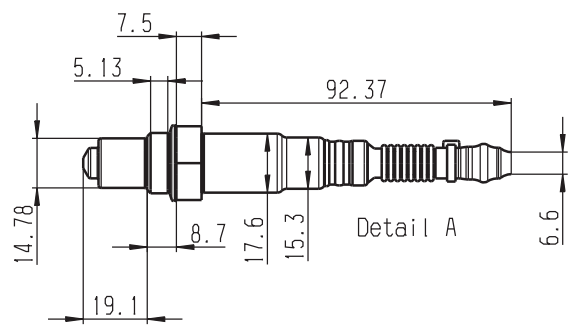

Pin Out	
1	IP
2	VM
3	RH
4	VS
5	IA
6	US
Mating Connector:	
D261 205 356-01	

Installation Torque:
40-60 Nm

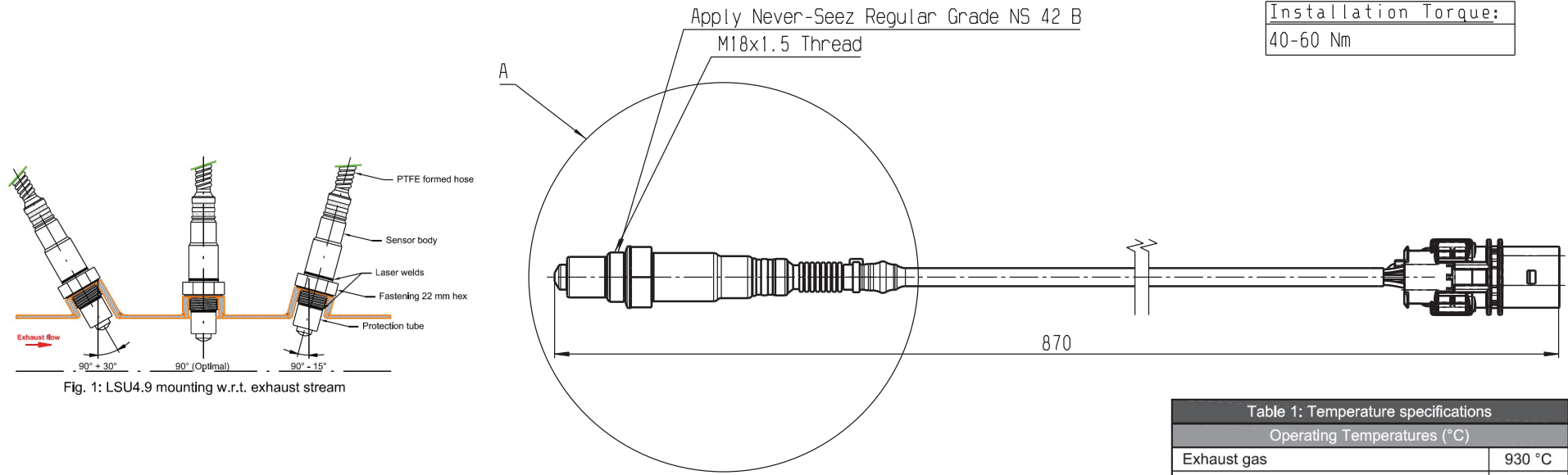

Fig. 1: LSU4.9 mounting w.r.t. exhaust stream

Table 1: Temperature specifications	
Operating Temperatures (°C)	
Exhaust gas	930 °C
Fastening 22 mm hex	600 °C
PTFE formed hose (sensor side)	250 °C
PTFE formed hose (upperhose crimp)	200 °C
Cable / protective sleeve	250 °C
Connector (OEM)	140 °C
Maximum Temperatures (°C)	
Exhaust Gas	1030 °C
Fastening 22 mm hex	680 °C

Table 2: Thread boss depth specifications		
Operating Temperatures (°C)	y (mm)	
Exhaust gas < 930	10.5	
Fastening 22 mm hex < 600	10.5	
Exhaust gas ≥ 930	13.0	
Fastening 22 mm hex ≥ 600	13.0	

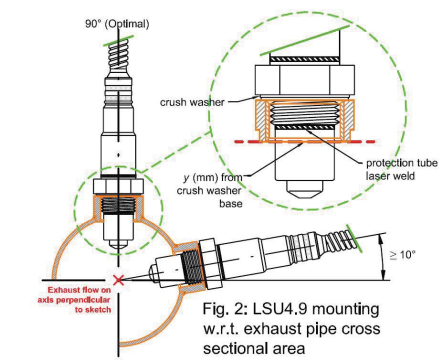

Fig. 2: LSU4.9 mounting w.r.t. exhaust pipe cross sectional area

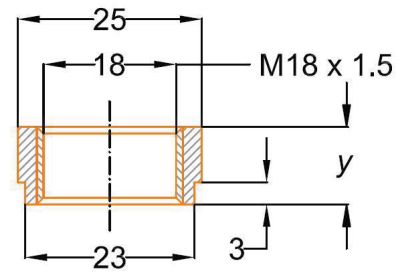

Fig. 3: LSU4.9 thread boss

02 Mounting	20151203	Brk	BeJ	OhE	MSD	BEG/MSD-NA	
01 Initial	20151106	Brk	OhE	OhE	MSD	BEG/MSD-NA	
Ind. Change/Änderung	YYYYMMDD	Drawn/Gez.	Checked/Gepr.	Releas./freig.	BWN	Resp. dept./Verantw. Abt.	Add. info./Zus. Info.
Lang./Spr.	Syst.	Vght./Gew.	LSU 4.9- IMSA				Sheet/Bl.
en/de	CAT	--					1/1
en	Scale/M.stab	NTS	OFFER DRAWING ANGEBOOTSZEICHN.				Format
MNR	--		Repl. for.				A3

## 9 Vibration Profile 1

## Vibration Profile 1

### Broadband noise: 8h/direction

Frequency (Hz)	Acceleration density (m/s <sup>2</sup> ) <sup>2</sup> /Hz
20	50.4
55	26.0
180	1.0
300	1.0
360	0.56
1,000	0.6
2,000	0.6
Effective value $a_{\text{eff}}$	55.4 m/s <sup>2</sup>

### Sine: 8h/direction

Frequency (Hz)	Acceleration peak (m/s <sup>2</sup> )
100	50
180	200
250	200
350	60
2,000	60



<b>Customer Information</b>		<b>PO Number:</b>	<b>Customer PO# if issued</b>
Team Name		Contact Name	
Car Make and Competition Class		Contact Email / Phone Number	
Shipping Preference (FedEx or UPS)		Shipping Address Line 1	
Shipping Account Number		Shipping Address Line 2	

Product Description	Part Number	Qty.	Use Case	Price	Tariff Charge	Total Price	Comments
<b>Spec Kit</b>							
GTP Kit (MS6-SCR with USB, VMPS+Antenna)	F02U.V0U.444-01			\$ 11,882.00	\$ 968.38	\$ 12,850.38	
IMSA GTP 2 Modem Telemetry Kit (2x LTE65, Antenna Package, Pit Stand Harness, 1 year of service)	F02U.V0U.446-01			\$ 21,213.00	\$ 508.97	\$ 21,721.97	
IMSA GTP 2 Modem Telemetry Kit (2x LTE65, Antenna Package, Pit Stand Harness, 1 year of service) - Endurance	F02U.V0U.447-01			\$ 13,786.00	\$ 508.97	\$ 14,294.97	
IMSA GTP 1 Modem Telemetry Kit (LTE65, Antenna Package, 1 year of service)	F02U.V0U.467-01			\$ 19,091.00	\$ 275.88	\$ 19,366.88	
IMSA GTP 1 Modem Telemetry Kit (LTE65, Antenna Package, 1 year of service) - Endurance Cup Only	F02U.V0U.468-01			\$ 11,665.00	\$ 275.88	\$ 11,940.88	
<b>Spec Sensors</b>							
Pressure Sensor - 0-1.15 Bar	F02U.V0U.267-02		Plenum, Inlet Port (NA)	\$ 483.00	\$ 39.36	\$ 522.36	
Pressure Sensor - 0-1.15 Bar (Automotive Connector)	F02U.V0U.204-01		Plenum, Inlet Port (NA)	\$ 313.00	\$ 25.51	\$ 338.51	
Pressure Sensor - 0-3.5 Bar	F02U.V0U.205-01		Boost (Turbo)	\$ 313.00	\$ 25.51	\$ 338.51	
Temperature Sensor - M6	F02U.V02.356-01		Engine, Cockpit	\$ 483.00	\$ 39.36	\$ 522.36	
Fuel Pressure and Temperature Sensor	F02U.V0U.194-01		Fuel at Flow Meter	\$ 302.00	\$ 24.61	\$ 326.61	
Air Jack Pressure Sensor (Automotive Connector)	0261.545.040		Air Jack	\$ 111.00	\$ 9.05	\$ 120.05	
Air Jack Pressure Sensor	F02U.V00.990.03		Air Jack	\$ 530.00	\$ 43.20	\$ 573.20	
Lambda Sensor	0258.988.001		Lambda	\$ 164.00	\$ -	\$ 164.00	
<b>Individual Spare Parts</b>							
MS6 SCR with USB	F02U.V03.353-01			\$ 9,225.00	\$ 751.84	\$ 9,976.84	
VMPS	F02U.V0U.445-01			\$ 2,647.00	\$ 215.73	\$ 2,862.73	
VMPS Antenna	F02U.00U.091-01			\$ 232.00	\$ 18.91	\$ 250.91	
VMPS Antenna Cable 66"	F02U.00U.092-01			\$ 103.00	\$ 8.39	\$ 111.39	
VMPS Antenna Cable 96"	F02U.00U.092-02			\$ 103.00	\$ 8.39	\$ 111.39	
VMPS Antenna Cable 120"	F02U.00U.092-03			\$ 103.00	\$ 8.39	\$ 111.39	
VMPS Antenna Cable 160"	F02U.00U.092-04			\$ 103.00	\$ 8.39	\$ 111.39	
LTE65 Modem - NA	F02U.V02.910-02			\$ 2,860.00	\$ 233.09	\$ 3,093.09	
LTE65 External Antenna (2 are required)	F02U.00U.087-01			\$ 19.00	\$ 1.55	\$ 20.55	
LTE65 SMA Bulkhead (2 are required for external antennas)	F02U.00U.088-01			\$ 36.00	\$ 2.93	\$ 38.93	
LTE65 SMA Cable, 90deg plug, 66" (1 of -01 or -02 is required for external antenna)	F02U.00U.089-01			\$ 93.00	\$ 7.58	\$ 100.58	
LTE65 SMA Cable, 90deg plug, 120" (1 of -01 or -02 is required for external antenna)	F02U.00U.089-02			\$ 103.00	\$ 8.39	\$ 111.39	
LTE65 SMA Bulkhead	F02U.00U.088-01			\$ 36.00	\$ 2.93	\$ 38.93	
LTE65 Pit Stand Harness	F02U.V02.804-02			\$ 525.00	\$ 42.79	\$ 567.79	
<b>Services</b>							
Annual Data Plan - IMSA GTP Kit	F02U.V0U.448-01			\$ 16,534.00	\$ -	\$ 16,534.00	
Annual Data Plan - GTP Endurance Cup Only Kit, 5 events	F02U.V0U.449-01			\$ 8,270.00	\$ -	\$ 8,270.00	
Annual Data Plan - Spare Modem	F02U.V0U.355-01			\$ 1,230.00	\$ -	\$ 1,230.00	
Annual Data Plan - IMSA GTP Single Modem	F02U.V0U.473-01			\$ 9,095.00	\$ -	\$ 9,095.00	
Annual Data Plan - IMSA GTP Educ. Cup Single Modem	F02U.V0U.474-01			\$ 4,547.00	\$ -	\$ 4,547.00	
Existing Modem Update to Latest Specification	TBD			\$ 950.00	\$ -	\$ 950.00	

**Notes**

To order parts please fill out this order form and create a Purchase Order matching your order and send both to Support.IMSA@us.bosch.com

All orders submitted are subject to the Bosch Motorsport terms and conditions.

All prices are in USD and are valid until 12/31/2025.

Unless customer has credit terms established with Bosch, all orders will require payment before parts will be shipped.

Customer is responsible for all shipping costs.

For sales/deliveries at the track, there is a 10% service charge

# Robert Bosch LLC – Bosch Engineering North America Motorsport Sales Terms & Conditions

Version: January 20, 2020

**1. GENERAL.** THE SALE OF COMPONENTS, PARTS, OR A SYSTEM INTENDED FOR SERIES PRODUCTION (“**SERIAL PRODUCTION PRODUCTS**” OR “**PRODUCTS**”), ALL SAMPLES, PROTOTYPES, NON-PRODUCTION PRODUCTS, AND COMPONENTS (INCLUDING SOFTWARE CONTAINED THEREIN) NOT APPROVED FOR SERIES PRODUCTION OR THAT ARE INTENDED FOR EVALUATION PURPOSES ONLY (“**PROTOTYPES**”), AND/OR DESIGN AND ENGINEERING OR SIMILAR SERVICES (“**SERVICES**”) PROVIDED BY ROBERT BOSCH LLC, THROUGH ITS BOSCH ENGINEERING NORTH AMERICA DIVISION (“**BOSCH**”) TO THE CUSTOMER (“**CUSTOMER**”) (EACH A “**PARTY**” AND COLLECTIVELY REFERRED TO AS “**PARTIES**”) IS EXPRESSLY LIMITED TO CUSTOMER’S ACCEPTANCE OF THE TERMS OF BOSCH’S OFFER (ALSO REFERRED TO AS THE “**QUOTATION**”) AND THESE BOSCH TERMS, EXCLUDING MODIFICATIONS TO THESE BOSCH TERMS SET FORTH IN THE APPLICABLE BOSCH QUOTATION. NO MODIFICATION OR WAIVER OF ANY OF THESE BOSCH TERMS AND NO ADDITIONAL OR DIFFERENT TERMS OR CONDITIONS WILL BE EFFECTIVE UNLESS EXPRESSLY SET FORTH IN BOSCH’S QUOTATION OR AGREED TO IN WRITING SIGNED BY BOSCH. NO ORAL AGREEMENT, COURSE OF PERFORMANCE, OR OTHER MEANS WILL BE DEEMED TO WAIVE THESE BOSCH TERMS OR ANY OF THE TERMS OF THE QUOTATION. CUSTOMER’S ACCEPTANCE OF THE PRODUCTS, PROTOTYPES, AND/OR SERVICES SOLD HEREUNDER WILL CONSTITUTE CUSTOMER’S ACCEPTANCE OF THE BOSCH QUOTATION AND BOSCH TERMS.

**2. SCOPE.** CUSTOMER acknowledges that Serial Production Products, whether or not modified, are not designed to meet the requirements and demands of motorsport racing.

CUSTOMER acknowledges that modified Serial Production Products and CUSTOMER specified Products cannot be tested to the same degree as Serial Production Products and that production of such modified Serial Production Products or CUSTOMER specified Products does not follow the testing and validation standards applicable to Serial Production Products. CUSTOMER acknowledges that the use of the Products in motorsport racing applications will lead to early wear, and that modified Serial Production Products or CUSTOMER specified products are produced with a focus on race performance and not on endurance. The terms of Sections 1 to 2 above apply irrespective of the CUSTOMER’s application of the Products.

**3. USE OF THE PRODUCTS.** The Products are provided solely for use by (i) racing professionals and CUSTOMER warrants and represents that it possesses the appropriate engineering and professional racing experience to use the Products for motorsport racing and (ii) research institutions trained by professionals. CUSTOMER acknowledges that the use of the Products may be dangerous and that the Products shall not be used in any consumer application. CUSTOMER shall use the Products: (i) only for motorsport racing purposes; (ii) only through engineers and mechanics who are trained and experienced in motorsport racing; (iii) only in vehicles, which are suitable for use in motorsport racing; (iv) only in such suitable vehicles that are operated by trained, professional motorsport race drivers; and (iv) research purposes by trained professionals. CUSTOMER shall not use, nor permit any other party to use, the Products in any vehicle operated on the public roads, or in connection with any consumer application. BOSCH shall not be liable for any use of the Products on the public roads. Should a Product be used on the public roads or in connection with any consumer application, all Product warranties are void.

**4. PRICES; TAXES; CURRENCY.** All prices are subject to the shipping terms defined in Section 6 below. Bosch reserves the right to adjust prices due to cost increases resulting from variations in labor rates, material costs, or other costs (including but not limited to variations

related to tariffs). To the extent the Products contain raw materials, raw material fluctuations will be reviewed on a quarterly basis. Actual material price increases of 5% or more will be paid in lump sum by CUSTOMER. The prices are exclusive of any applicable Federal, State, Provincial, or local sales, use, and other similar taxes or assessments. Such taxes and assessments will be included in Bosch’s invoice and paid by CUSTOMER. CUSTOMER shall be solely responsible for its tax administration and tax liability based upon governing Federal, State, and local laws that relate to these BOSCH Terms. All prices are subject to adjustment, at any time, by Bosch for changes in volume forecasts, economics, or exchange rates as applicable. To the extent CUSTOMER’s actual purchases fall short of the volume forecasts upon which the prices were based, any price adjustments by Bosch will be retroactive. Prices are per piece in U.S. Dollars or EUR. All North American CUSTOMER facilities will be invoiced in U.S. Dollars. Each payment by CUSTOMER is subject to the terms of Section 8 below and will be made without withholding any taxes, unless required by law. CUSTOMER shall inform Bosch of any withholding tax obligation on payments due to Bosch under an invoice as soon as CUSTOMER becomes aware of such withholding tax obligation. If Bosch believes that it is eligible for exemption from, or reduction of, any U.S. withholding tax (or other withholding or similar tax of one or more other jurisdictions), Bosch will deliver to CUSTOMER a completed, duly executed IRS Form W-9 or Form W-8 (or other appropriate form of such other jurisdiction(s) as required under the laws of such other jurisdiction) valid through the date of payment. In such event, CUSTOMER shall promptly deliver to Bosch a certificate evidencing the payment of any tax actually withheld.

**5. CANCELLATIONS AND CHANGES.** No cancellations of or changes ordered by CUSTOMER to the Products, Prototypes, and/or Services or any delivery or pickup terms related thereto will be effective without Bosch’s written consent and in the event of any such cancellation or change, Bosch will be entitled to all remedies available by law or equity, including without limitation cancellation costs, warehousing fees, and/or increased prices. At a minimum, CUSTOMER will be liable for the following items, or any applicable combination thereof: (a) Products, Prototypes delivered, and/or Services performed prior to cancellation or change that comply with the specifications and other requirements of the Quotation; (b) the reasonable cost of raw materials and components that were purchased by Bosch to meet the requirements of the Quotation and that cannot be returned for refund or credit or immediately used for or sold to any of Bosch’s other CUSTOMERS; (c) the reasonable costs to settle all claims by subcontractors for actual costs that are rendered unrecoverable due to cancellation or change; and (d) the reasonable costs of reassignment of Bosch’s employees specifically dedicated to the satisfaction of Bosch’s obligations under the Quotation, provided Bosch uses reasonable efforts to reassign each such employee.

**6. SHIPMENT AND DELIVERY.** All delivery dates are estimates only. Bosch’s only obligation with respect to delivery dates will be to use reasonable efforts to meet such delivery dates. Unless specified otherwise in the Quotation, the delivery terms will be FCA (as defined in Incoterms® 2010) at the designated Bosch facility. Title and risk of loss to the Products and Prototypes will transfer upon completion of delivery of the Products and Prototypes per the applicable delivery term specified above. Unless otherwise instructed, Bosch will ship via industry standard means for the applicable Products and Prototypes. Bosch will not be liable for any delays, breakage, loss, or damage after having made delivery in good order to the first transportation carrier. All claims for loss or damage in transit are to be made by CUSTOMER directly to the transportation carrier and the appropriate insurance carrier retained by CUSTOMER. CUSTOMER shall not make any deductions of any kind from the invoice amount. Unless otherwise specified in the Quotation, standard packing for domestic shipment is included in the quoted price. When special domestic or export packing is requested, CUSTOMER will be charged for any additional expenses. Shipments will be deemed accepted by CUSTOMER unless written

notice of rejection is received by Bosch within ten (10) days after receipt of the Products and Prototypes by CUSTOMER. For rejected shipments, CUSTOMER will bear the risk of loss or damage to the Products and/or Prototypes in transit. If Bosch reasonably determines that the rejection was improper, CUSTOMER will be responsible for all expenses incurred by Bosch arising from the improper rejection.

**7. FORCE MAJEURE.** In the event either Bosch or CUSTOMER is unable to fully perform its obligations hereunder (except for CUSTOMER's obligation to pay invoices for Products, Prototypes, and/or Services) due to events beyond its reasonable control, including without limitation, acts of God, action by any governmental authority (whether valid or invalid), fires, floods, windstorms, explosions, riots, natural disasters, wars, sabotage, labor problems (including lockouts, strikes, or slowdowns), inability to obtain power, material, labor, equipment or transportation, or court injunction or order (collectively referred to herein as a "Force Majeure Event"), that party shall be relieved of its obligations to the extent it is unable to perform such obligations. A Party experiencing a Force Majeure Event shall provide reasonable notice of such Force Majeure Event to the other Party. In the event of Bosch's inability to perform due to a Force Majeure Event, Bosch may allocate available goods and materials among its CUSTOMERs and CUSTOMER will be entitled to reduce its purchase obligations toward Bosch by the quantities purchased from other sources, but shall not have the right to terminate these BOSCH Terms.

**8. PAYMENT TERMS.** Unless specified otherwise in the Quotation, terms of payment are net thirty (30) days from the earlier of the date of shipment or the date of an invoice, with no discount allowed for early payment. Bosch reserves the right to reclaim any Products, Prototypes, and/or Services that have not been paid for in full and Bosch reserves the right to alter or suspend credit terms or require C.O.D. or advance payment whenever Bosch has reasonable doubt as to CUSTOMER's credit worthiness or the ability of CUSTOMER to pay in a timely manner. If CUSTOMER becomes delinquent in payment or refuses to accept C.O.D. shipments, Bosch will have the right to, in addition to all other available rights and remedies, cancel any or all CUSTOMER orders, withhold further deliveries, and declare all unpaid amounts for Products, Services, and/or Prototypes previously delivered immediately due and payable. Amounts past due will be subject to an interest charge of 1.5% per month or the maximum rate allowed by law, whichever is less. CUSTOMER shall pay all costs and expenses incurred by Bosch as a result of non-payment or delinquent payment by CUSTOMER, including without limitation collection costs, interest, and reasonable attorneys' fees.

## **9. WARRANTY**

9.1 Unless specified otherwise in BOSCH's quotation BOSCH warrants that, upon delivery, the Products will be free of defects in material and workmanship. BOSCH's warranty covers only defects that existed at the time of delivery. The foregoing warranty: (i) is personal to CUSTOMER and does not extend to any subsequent owner of the Products; and (ii) does not cover defects which occur due to the use in a motorsport environment.

9.2 CUSTOMER acknowledges that the Products are designed for race performance, with reduced durability and stability, and that the extreme wear inherent in a racing environment may result in Product malfunction which will not be covered by the limited warranty set forth above.

9.3 BOSCH does not warrant that modified Serial Production Products or CUSTOMER specified Products will display the features or operational performance requested or expected by CUSTOMER.

9.4 BOSCH will provide free of charge to CUSTOMER, replacement Products or, at BOSCH's option, credit in a fair amount not to exceed the purchase price for Products which prove to be defective under the limited warranty set forth above, provided, however, that CUSTOMER has returned to BOSCH 100% or a statistically relevant share, as mutually agreed upon, of any Products claimed to be defective. BOSCH shall have the right to request reasonable evidence of, and impose reasonable requirements for, submission of a warranty claim including, by way of example and not limitation, printouts of diagnostic test results performed at the CUSTOMER's dealer level or by CUSTOMER.

9.5 In the event of (a) improper installation or misuse of the Products, (b) use of Products outside of BOSCH approved applications, specified environments or installation conditions, (c) use of Products for racing or testing applications, (d) failure to maintain Products in accordance with applicable maintenance instructions, or (e) alteration or damage caused to the Product, or similar circumstances, no warranty shall apply and BOSCH shall not be liable for such Products or any damage caused by such products.

9.6 THIS WARRANTY IS IN LIEU OF ALL OTHER WARRANTIES EXPRESS OR IMPLIED INCLUDING OF MERCHANTABILITY OR FITNESS FOR A PARTICULAR PURPOSE. THE FOREGOING WARRANTY DOES NOT APPLY TO ANY ISSUES STEMMING FROM CUSTOMER'S USE OF THE PRODUCT IN ANY APPLICATION. THE REMEDIES SET FORTH IN THIS SECTION REPRESENT CUSTOMER'S SOLE AND EXCLUSIVE REMEDIES FOR ANY BOSCH BREACH OF WARRANTY.

## **10. PROTOTYPE WARRANTY AND USE.**

10.1 PROTOTYPES ARE PROVIDED "AS IS" AND ALL WARRANTIES, EXPRESSED OR IMPLIED, ARE DISCLAIMED AND EXCLUDED, INCLUDING WITHOUT LIMITATION WARRANTY OF MERCHANTABILITY, FITNESS FOR A PARTICULAR PURPOSE, OR FREEDOM FROM THIRD PARTY RIGHTS, WHETHER ARISING BY LAW, COURSE OF DEALING, COURSE OF PERFORMANCE, OR OTHERWISE. BOSCH DOES NOT WARRANT THAT THE PROTOTYPES WILL BE ERROR FREE OR SECURE. PROTOTYPES ARE NOT DESIGNED FOR AND SHOULD NOT BE USED IN ANY FAIL-SAFE APPLICATIONS.

10.2 CUSTOMER acknowledges that Prototypes are intended only for use in evaluation and testing in a suitable and safe evaluation and testing environment and by suitably trained and qualified persons. CUSTOMER shall ensure safe operating conditions for all evaluation and testing purposes at all times during the evaluation and testing. CUSTOMER warrants that no vehicles containing any Prototypes will be driven on public roads, unless and until CUSTOMER and Bosch agree in writing. CUSTOMER shall only use the Prototypes in accordance with written instructions from Bosch. Any use or application of Prototypes, which deviates from written instructions from Bosch, will be considered an impermissible use in breach of these BOSCH Terms. Any use, testing or evaluation of the Prototypes outside the scope of this Section 10.2 or as agreed in writing between the parties shall be at CUSTOMER's sole risk.

## **11. TERMINATION/CANCELLATION.**

11.1 Bosch may terminate the CUSTOMER's purchase order/acceptance of the Quotation: (a) upon written communication to CUSTOMER in the event CUSTOMER breaches any material term of the Quotation or these BOSCH Terms, provided CUSTOMER has not remedied the breach within 30 days of Bosch providing notice to CUSTOMER of such breach; or (b) if CUSTOMER becomes insolvent or makes an assignment for the benefit of creditors, or CUSTOMER institutes any voluntary proceeding under bankruptcy, reorganization, arrangement, readjustment of debt, or insolvency law of any jurisdiction or for the appointment of a receiver or trustee in respect to any of CUSTOMER's property, then termination shall be automatic and immediate; however, in the event any such proceeding is initiated by a third party against CUSTOMER, termination will be automatic if the such proceeding is not dismissed or cured by CUSTOMER within thirty (30) days after the filing thereof. Bosch shall not be liable to CUSTOMER for any claims arising out of or based on termination in accordance with this Section 11.1.

11.2 In the event that CUSTOMER cancels the program after business award but before the agreed upon end of program duration, CUSTOMER shall reimburse Bosch for reasonable cancellation charges for unrecoverable costs and investments, including without limitation capital equipment, finished Products, cost of all work in process, Bosch paid tooling or licenses (including software licenses and maintenance agreements), engineering costs, application costs, development services, samples, and material obsolescence. CUSTOMER shall pay such cancellation charges in accordance with Section 8.

## **12. INTELLECTUAL PROPERTY/SOFTWARE.**

12.1 INTELLECTUAL PROPERTY RIGHTS. As between Bosch and CUSTOMER, Bosch exclusively owns and shall retain exclusive

ownership of all right, title, and interest, including all worldwide patent, trademark, copyright, trade secret, and other intellectual property and proprietary rights (collectively, "**Intellectual Property Rights**") in and related to (a) the Products; (b) the Prototypes; (c) the Services; and (d) all other ideas, inventions (whether patentable or not), concepts, designs, methods, processes, software (including source code and object code), data, and works of authorship authored, developed, or conceived by Bosch in connection with the Products, Prototypes, or Services, along with all software, functions, and related documentation provided by Bosch or any division or affiliate thereof. Bosch reserves the right to brand, mark, or label the Products, Services, and Prototypes and accompanying packaging with Bosch trademarks. Products or Services delivered from Bosch to the independent aftermarket will bear the Bosch trademarks only.

**12.2 THIRD PARTY INTELLECTUAL PROPERTY RIGHTS INDEMNIFICATION.** Bosch shall indemnify, defend, and hold harmless CUSTOMER against all final judgments of infringement in the United States of the Intellectual Property Rights of any third party registered and published in the United States (specifically excluding claims of infringement of any affiliate of CUSTOMER) and resulting direct damages and expenses (including reasonable attorney's fees) arising out of use of any Product or Service as delivered by Bosch, provided Bosch shall have no liability and shall not indemnify, defend, or hold harmless CUSTOMER for or against any claim arising from (i) CUSTOMER's gross negligence or willful or intentional acts or omissions; or (ii) any modification or alteration of any Products or Services, unless prior written authorization for such modification or alteration is provided by Bosch in writing; or (iii) use of the Products or Services in combination with any other equipment, software, products or services not supplied by Bosch and the use of such combination was not authorized by Bosch; or (iv) CUSTOMER's designs, specifications, requirements, or instructions; or (v) the application or use of any Products or Services which fails to comply with the specification or other written instruction from Bosch; or (vi) the implementation of Standardized Technologies, to the extent the indemnification obligation stems from the Standardized Technologies or implementation related thereto (as used herein "Standardized Technologies" means technical specifications or functions (x) adopted by a standards organization (e.g., ETSI or IEEE), (y) defined by research institutes, industrial companies, or market participants to ensure technical conformity or compatibility, or (z) established by common practice in a particular field). For the sake of clarity, no indemnification or warranty is provided for Prototypes.

**12.3** Bosch shall be entitled, at its discretion, to: (i) obtain a right of use for a Product or Service alleged to infringe an Intellectual Property Right, (ii) to modify the Product or Service so that it no longer infringes the Intellectual Property Right, or (iii) to replace the Product or Service with an equivalent substitute that no longer infringes the Intellectual Property Right. Bosch reserves the right to carry out the actions of (i)-(iii) in the sentence above at its disposal even if the infringement of the Intellectual Property Right has not been ruled on by a court of law with res judicata effect or acknowledged by Bosch. If Bosch determines that options (i), (ii) or (iii) are not reasonably available, Bosch shall be considered to have fulfilled its obligations under this Section 12 by returning the fees paid by CUSTOMER for Products or Services which are subject to the infringement claim.

**12.4 INDEMNIFICATION FROM CUSTOMER.** To the fullest extent permitted by applicable law, and subject to the conditions applicable to claims by CUSTOMER against Bosch under Section 12.2, CUSTOMER shall indemnify, defend, and hold harmless Bosch, its affiliates, and their respective directors, officers, employees, successors, and assigns for all claims, liabilities, damages, costs, and expenses (including reasonable attorney fees) asserted by a third party (specifically excluding any affiliate of Bosch) and incurred by Bosch in connection with such claims (including lawsuits, administrative claims, regulatory actions, and other proceedings to recover for personal injury or death, property damage, or economic losses) to the extent caused by: (i) CUSTOMER's or Bosch's infringement or misappropriation of any Intellectual Property Rights of any third party caused by (a) CUSTOMER's technology, products, or services, or Bosch's use thereof in accordance with these BOSCH Terms or any applicable Quotation, or (b) any modification or alteration of any Products or Services by CUSTOMER, unless prior written authorization for such modification or alteration is provided by Bosch in writing; or (ii) bodily injury or property damage resulting from CUSTOMER's integration of the Products or

Services into vehicle systems or other components within the vehicle system in a manner that is not approved by Bosch or in compliance with all applicable laws; or (iii) any grossly negligent act or omission of CUSTOMER or any of its employees or agents; or (iv) CUSTOMER's failure to comply with representations, performance, or obligations under these BOSCH Terms or the applicable Quotation; or (v) any design, hardware, software, data, instructions, requirements, or material expressly required or supplied by CUSTOMER.

**12.5** The indemnified Party under Sections 12.2 or 12.4 shall give prompt written notice to the indemnifying Party of the claim for which it seeks indemnification (provided that the failure to give such notice will not relieve the indemnifying Party of its obligations under Sections 12.2 or 12.4, except to the extent that such failure materially prejudices the indemnifying Party's ability to carry out its obligations under Sections 12.2 or 12.4). The indemnifying Party will assume and direct the defense and settlement of any such claim with counsel of the indemnifying Party's reasonable choosing; the indemnified Party will provide the indemnifying Party, at the indemnifying Party's expense, with such information and assistance as may be reasonably necessary for the defense and settlement of the claim. CUSTOMER will not settle or resolve any such claim without the advance written approval of Bosch, approval not to be unreasonably withheld or delayed, unless such settlement or resolution includes a full and unconditional release of Bosch with no admission of guilt from Bosch or its affiliates.

**12.6 SOFTWARE.** Notwithstanding anything to the contrary set forth in an applicable Quotation or these BOSCH Terms, and excluding any OSS (defined below), all Bosch software and firmware that has been loaded onto, incorporated into, or provided by Bosch in connection with the Products, Prototypes, or Services (the "**Software**") is and remains owned by Bosch. or its affiliates. All Software is provided with only a limited right to use as delivered in connection with hardware and/or in accordance with the applicable software license provided to CUSTOMER. In the event any Software contains a click-through, pop-up, or other end-user license agreement (collectively, "**EULA**"), the terms of such EULA shall control over the terms of the applicable Quotation or these BOSCH Terms to the extent the terms of the EULA conflict with the Quotation or BOSCH Terms. In the event CUSTOMER does not accept the EULA at the time of delivery, (i) CUSTOMER shall not use the applicable Software or hardware incorporating such Software for any purpose and return the Software or corresponding hardware within ten (10) days of receipt thereof, and (ii) any use of the Software will be considered an unauthorized use in breach of these BOSCH Terms and the EULA. Unless expressly agreed otherwise, Bosch has no obligation to provide any updates or upgrades to the Software (including, without limitation correcting any bugs identified by Bosch, CUSTOMER, or any third party). Notwithstanding the foregoing sentence, Bosch reserves the right to make the availability of updates, upgrades, and new releases at its sole discretion or conditional upon the existence of a valid service contract.

**12.7 OPEN SOURCE SOFTWARE.** Products, Prototypes and Services which incorporate Software may contain free or open source software ("OSS"). Such OSS is always subject to separate third party OSS licensing terms and conditions ("**OSS-Terms and Conditions**"). The OSS-Terms and Conditions come into effect between CUSTOMER and the authors of the respective OSS. Under such OSS-Terms and Conditions, Bosch is required to provide the same to CUSTOMER and CUSTOMER itself has to obey all of the OSS-Terms and Conditions and to fulfill all corresponding obligations in case CUSTOMER further disposes of the Products, Prototypes, or Services through sales or other transfer to third parties. Such obligations may include, for example, documentation obligations or obligations to provide the source code of any software integrated in a product in which the OSS has also been integrated by CUSTOMER. An overview about all OSS components contained in the Products, Prototypes, or Services as well as corresponding license text of the OSS-Terms and Conditions (of all originating OSS authors) are part of Bosch's delivery of the Product, Prototype, or Service (e.g. as part of the provided documentation, in a display field within a device, etc.). To the extent that new software versions included in Bosch's Products, Prototypes, and Services may contain other and/or additional OSS, the same terms and conditions apply as stated in this Section 12.7.

**12.8 CUSTOMER'S USE OF OPEN SOURCE SOFTWARE.** CUSTOMER shall use reasonable commercial efforts to not combine or request or otherwise cause others to combine Bosch Software,

Products, Prototypes, and/or Services with any OSS or other data in any manner that would result in the Bosch Software, Products, Prototypes, and/or Services becoming subject to the terms of an OSS license. For any software provided to Bosch by CUSTOMER or on behalf of CUSTOMER, CUSTOMER shall disclose in writing a list of all applicable OSS-Terms and Conditions and/or third party license terms at the time of delivery of such software to Bosch, and CUSTOMER shall indemnify Bosch for all costs, expenses, and damages caused by CUSTOMER's failure to disclose OSS-Terms and Conditions and/or third party license terms in software provided by CUSTOMER, directed by CUSTOMER, or on behalf of CUSTOMER.

12.9 NO REPRODUCTION. Unless otherwise permissible under law or agreed to by Bosch in writing, CUSTOMER shall not itself and shall not enable or instruct others to copy/reproduce, reverse engineer, decompile, disassemble, translate, or fragment parts of Software or Prototypes provided by Bosch and CUSTOMER shall treat such Software and Prototypes as Confidential Information as defined in Section 12 of these BOSCH Terms.

**13. GOVERNMENT CONTRACTS.** If Products, Prototypes, and/or Services are purchased under a government contract or sub-contract, CUSTOMER shall promptly notify Bosch of the provisions of any government procurement laws and regulations which are required to be included in the contract covering the Products, Prototypes, and/or Services ordered. If compliance with such provisions increases Bosch's costs or liability, or encumbers any Bosch Intellectual Property Rights, Bosch will be entitled, at its option, to adjust the prices accordingly, request separate payment of the additional costs, or terminate this Agreement. CUSTOMER shall be responsible for all costs incurred by Bosch related to such compliance.

**14. CONFIDENTIAL INFORMATION.** Any and all non-public information and data concerning the Products, Prototypes, Services, or any other transaction covered hereunder which Bosch discloses to CUSTOMER, is generated by the Products, Prototypes, or Services, or which CUSTOMER otherwise obtains knowledge of hereunder, and any non-public technical, financial, or business information, trade secrets, orders, content, Prototype, or other information provided by Bosch to CUSTOMER (collectively, "**Confidential Information**") remains the exclusive property of Bosch and shall not be disclosed by CUSTOMER to third parties without Bosch's express written consent. Confidential Information shall be held in confidence and shall not be disclosed and shall not be used except to the extent necessary to carry out CUSTOMER's obligations or express rights hereunder, unless otherwise authorized by Bosch in writing. For the sake of clarity, CUSTOMER shall have no right whatsoever to such Confidential Information other than to use it for evaluation for the purpose of the transaction covered hereunder. If the CUSTOMER is compelled by law to disclose Bosch's Confidential Information, and a protective order or other remedy is not obtained, CUSTOMER shall furnish only that portion of the Confidential Information that is legally required and CUSTOMER shall use commercially reasonable efforts to obtain assurance that confidential treatment shall be accorded the Confidential Information. This Section 14 (Confidentiality) shall survive the termination or expiration of any purchase order, accepted Quotation, or other termination of CUSTOMER's use of or CUSTOMER's right to use the Products, Prototypes, and/or Services.

**15. REMEDIES/LIMITATION OF REMEDIES.** Bosch's rights and remedies set forth herein shall be in addition to any legal or equitable right or remedy available to Bosch. No waiver of any of Bosch's rights or remedies shall be effective without Bosch's express written consent. CUSTOMER's sole and exclusive remedy after acceptance of the Products or Services shall be the remedy available under the respective warranty provision.

**16. LIMITATION OF LIABILITY.**

The liability of BOSCH, and its respective affiliates, officers, directors, employees, shareholders, agents, licensors, or representatives (collectively the "BOSCH Parties") for any claim, regardless of the form of action, whether in contract, tort or negligence, for any damages resulting from or in any manner connected with this Agreement and any Products, shall be limited to the lesser of (i) CUSTOMER's actual direct damages related thereto, or (ii) the amount of the fees paid by

CUSTOMER for the portion of the Products which are in error. In no event shall the liability of the BOSCH Parties exceed the fees paid by CUSTOMER during the period such damages were incurred, such period not to exceed three (3) months, for the specific Products that allegedly give rise to the damages.

In no event shall any of the BOSCH Parties be liable for any indirect, incidental, special or consequential damages including, but not limited to, loss of data, lost business, lost profits and other economic damages, whether foreseeable or not, even if advised of the possibility of such damages. Without limiting the generality of the foregoing, the BOSCH Parties shall not be liable to CUSTOMER with respect to the quality or sufficiency of any business results or motorsport racing results to be achieved with the use of the Products.

CUSTOMER agrees, acknowledges and confirms that the limitations of liability set out in this Section are fair and reasonable in the commercial circumstances of this Agreement and that BOSCH would not have entered into this Agreement but for CUSTOMER's agreement to limit the liability of the BOSCH Parties in the manner, and to the extent, provided herein. The limitations of liability set out in this Section shall apply even in the event of a breach of condition, a breach of an essential or fundamental term, or a fundamental breach of this Agreement.

**17. EXPORT.** CUSTOMER will not sell, distribute, resell, or transfer (hereinafter collectively, "**Transfer**") any Product, Prototype, or Services, including commodities, software and technology/technical data, plans, and specifications relating to the Product, Prototype, or Services (collectively, "**Export Control Products**") or take any actions in relation to or in furtherance of these BOSCH Terms, which are contrary to U.S. Export Regulations, including but not limited to U.S. Department of Commerce Export Administration Regulations ("**EAR**"), the U.S. Treasury Office of Foreign Assets Controls ("**OFAC**"), U.S. Department of State International Traffic in Arms Regulations ("**ITAR**"), or any other applicable export control, import control, and economic sanction laws and regulations of the US or any country or countries (collectively, "**Export/Import Control Laws**"). CUSTOMER further acknowledges that Export/Import Control Laws, include but are not limited to, prohibitions against: (a) Transfer any product to U.S. embargoed countries (currently, Cuba, Iran, North Korea, Syria, and Sudan); (b) Transfer of ITAR product to any country with which the U.S. maintains an Arms Embargo; (c) Transfer of certain EAR controlled product for China, Russia, and Venezuela military end-use; (d) Transfer to certain OFAC sanctioned persons or countries; and (e) other restrictions as defined in the Export/Import Control Laws. CUSTOMER will immediately notify Bosch and cease activities with respect to a sale if CUSTOMER knows or has a reasonable suspicion that an Export Control Product has been or may be exported, re-exported, transferred, or released in violation of Export/Import Control Laws. Unless otherwise mutually agreed in writing, CUSTOMER agrees that it will not use an Export Control Product in connection with any activity involving nuclear fission or fusion, any use or handling of any nuclear material, or any nuclear, chemical or biological weapons. CUSTOMER shall defend, indemnify, and hold Bosch harmless from any and all losses suffered by Bosch as a direct result of CUSTOMER's or its CUSTOMERs' non-compliance with Export/Import Control Laws. Bosch will not be liable to CUSTOMER for failure to provide Products, Prototypes, Services, transfers, or technical data as a result of any government actions that impacts Bosch's ability to perform, including: (a) the failure to provide or the cancellation of export or re-export licenses; or (b) any subsequent interpretation of applicable import, transfer, export, or re-export law or regulation after the date of any order or commitment that has a material adverse effect on Bosch's performance.

**18. ELECTRONIC DATA EXCHANGE; VEHICLE DATA; PRIVACY.**

18.1 ELECTRONIC DATA EXCHANGE. Bosch supports most electronic data exchange systems. Each party bears responsibility for its data input and for the part of the system for which it is responsible.

18.2 VEHICLE DATA. CUSTOMER hereby grants to Bosch the unlimited right to use and sublicense to Bosch affiliates, agents, consultants, and subcontractors the unlimited right to use Vehicle Data (defined below) or any portion thereof, wherein such use may include, without limitation, copying, aggregating, creating derivatives, and/or

anonymizing such Vehicle Data, for the following purposes: (i) the investigation of any accidents or claims related to a defect, failure, or alleged defect or failure of Bosch's Products, Prototypes, or Services; (ii) research and development related to improvement, analyses, and modification of Bosch's Products, Prototypes, and Services; (iii) the defense of any claim against Bosch brought by CUSTOMER or any third party; and (iv) any other purpose as mutually agreed in writing between the parties. To the extent Bosch does not have direct access to or does not directly receive Vehicle Data, CUSTOMER shall provide access or otherwise deliver to Bosch all Vehicle Data in the possession of CUSTOMER within thirty (30) days after written request from Bosch or on a continual basis, if mutually agreed between the parties. Bosch shall not disclose Vehicle Data to any third party, other than (i) affiliates, and (ii) agents, consultants, and subcontractors contractually required to maintain the confidentiality of Vehicle Data. As used herein, "**Vehicle Data**" means any and all data produced, collected, transmitted, or processed by Bosch's Products, Prototypes, or Services, including without limitation components, systems, modules and electronic control units.

**18.3 PROTECTION OF PERSONAL INFORMATION.** The terms of the Data Protection Addendum at, available upon request, are hereby incorporated by reference and shall apply to the extent that Vehicle Data includes Personal Data (as defined below) or Bosch processes Personal Data for or on behalf of CUSTOMER as part of the Services. Bosch and CUSTOMER shall complete Bosch's Data Protection Addendum. "**Personal Data**" means any information relating to any identified or identifiable natural person.

**19. COMPLIANCE WITH LAWS.** Each party represents and warrants to the other party that it and its employees and agents are and will continue to be in compliance with all applicable laws and regulations relating to its performance under the Quotation and these BOSCH Terms, including without limitation laws associated with testing and evaluation of vehicles and Prototypes on a public roadway, and any laws or regulations relating to the processing of Vehicle Data. The applicable laws and regulations that Bosch must comply with are only those jurisdictions set forth in the applicable Quotation.

**20. SET-OFF.** CUSTOMER is not entitled to and shall not set-off any amounts due or allegedly due from Bosch to CUSTOMER from CUSTOMER's debts towards Bosch.

**21. ASSIGNMENT.** Neither Party shall assign its rights or obligations hereunder without the other Party's prior written consent. A corporate reorganization, which does not result in a change of control or beneficial owner, will not be deemed an assignment.

**22. RELATIONSHIP OF THE PARTIES.** CUSTOMER and Bosch are independent contracting parties. Nothing hereunder or in the course of performance under the Quotation or these BOSCH Terms will grant either Party the authority to create or assume an obligation on behalf of or in the name of the other Party or will be deemed to create the relationship of joint venture, partnership, association, or employment between the Parties.

**23. SEVERABILITY.** In the event that any provision of these BOSCH Terms or the Quotation is declared by a court to be void or unenforceable, the validity of any other provisions and of the entire BOSCH Terms or the Quotation will not be affected thereby.

**24. APPLICABLE LAW; ARBITRATION.** These BOSCH Terms, the Quotation, and all disputes between the Parties arising out of or related thereto shall be governed by the laws of the State of Michigan except for its choice of law rules; the United Nations Convention on the International Sale of Goods shall not apply. The Parties acknowledge that these BOSCH Terms and the applicable Quotation evidences a transaction involving interstate commerce. The Parties shall first endeavor to resolve through good faith negotiations any dispute arising under or relating to these BOSCH Terms and the applicable Quotation. If a dispute cannot be resolved through good faith negotiations within thirty (30) days either Party may request non-binding mediation by a mediator approved by both Parties. If mediation fails to resolve the dispute within thirty (30) days after the first mediation session, then,

upon notice by either Party to the other, any and all disputes, controversies, differences, or claims arising out of or relating to these BOSCH Terms and the applicable Quotation (including the formation, existence, validity, interpretation (including of this Arbitration clause), breach, or termination thereof) shall be resolved exclusively through binding arbitration, except that either Party shall have the right, at its option, to seek injunctive relief, under seal to maintain confidentiality to the extent permitted by law, (i) in either the Michigan Circuit Court for the County of Oakland or the United States Court for the Eastern District of Michigan, or (ii) pursuant to the American Arbitration Association ("AAA") Optional Rules for Emergency Measures of Protection. A request by a Party to a court of competent jurisdiction for such interim measures shall not be deemed incompatible with, or a waiver of, this agreement to arbitrate. The Parties agree that any ruling by the arbitration tribunal on interim measures shall be deemed to be a final award for purposes of enforcement. The arbitration proceedings shall be conducted in accordance with the Commercial Arbitration Rules of the AAA including application of the Optional Rules for Emergency Measures of Protection as amended from time to time, except as modified by this clause or by mutual agreement of the Parties, and shall be governed by the United States Federal Arbitration Act. Within 14 days after the commencement of arbitration, each Party shall select one person to act as arbitrator and the two selected shall select a third arbitrator within 10 days of their appointment. If the arbitrators selected by the Parties are unable or fail to agree upon the third arbitrator, the third arbitrator shall be selected by the AAA. The arbitration shall be conducted in Detroit, Michigan, and the language of the arbitration shall be English. The arbitrators' award shall be final and binding. The arbitrators shall issue a written opinion setting forth the basis for the arbitrators' decision. The written opinion may be issued separately from the award, in the arbitrators' discretion. Each Party shall bear its own attorney fees and costs, and each Party shall bear one half the cost of the arbitration hearing fees, and the cost of the arbitrators, unless the arbitrators find the claims or defenses to have been frivolous or harassing, in which case the arbitrators may award the party responding to such frivolous or harassing claims/defenses its costs of the arbitration and/or reasonable attorney fees, in the arbitrators' discretion. Either Party may apply to have the arbitration award confirmed and a court judgment entered upon it. Venue for confirmation of or any challenge to the Arbitration Award shall be in either the Michigan Circuit Court for the County of Oakland or the United States Court for the Eastern District of Michigan and shall be done under seal to maintain confidentiality to the maximum extent permitted by law. The arbitrators shall have no authority to award punitive damages or any other damages excluded herein, to the maximum extent permitted by law. Except as may be required by law, neither a Party nor their counsel nor an arbitrator may disclose the existence, content, or results of any arbitration hereunder without the prior written consent of both Parties.

**25. SURVIVAL.** Any right or obligation of a Party which, by its nature or context is intended to survive termination or expiration of the applicable Quotation or these BOSCH Terms, will survive any such termination or expiration, including without limitation Sections 14-26.

**26. VALIDITY OF QUOTATION.** Any Quotations issued subject to these BOSCH Terms will be valid for 30 days from the date of issuance unless stated otherwise in the Quotation.

# 11 Revisions

V0.6.5	Initial Draft Release
V0.7	Airjack Pressure Part Change MS6 SCR Part Number Added General Revisions
V1.0	Initial Official Release VMPS and LTE65 Part Numbers Added Order Form Updated VMPS Drawing Added XAP Leaderlight Added to Harness
V1.0.4	Additional Loom Homologation Guidance
V1.0.4	Updated P/N for 0-1.15 bar pressure sensor
V1.3.1	Additional Loom Certification Guidance TPMS Functional Description Update
V1.3.3	Order Form updated – SMA cables
V1.3.4	Information on Telemetry Ground Plane
V1.4.0	Updated for 2025 system architecture - torque sensor, wheel speed, throttle position, TPMS and fuel probe sensor requirements. Wiring diagram update to include fuel probe sensor, USB wire shielding. Grammatical and format corrections Updated links. Updated scrutineering diagnostics port mounting example. Regulatory updates PPU Test Mode Function Description
V1.4.1	Updated Telemetry wording VMPS image updated. X2 Transponder mounting detail. Instances of "Scrutineering System homologation"-> Homologation 2025 Bosch Ordering Form
V1.4.2	Removal of references to Internal Antenna CAN Bus Delta Image quality improved
V1.4.3	Engine Speed sensor pin 2,3 polarity definition. Wiring Diagram Engine Speed sensor polarity image updated + -. Torque Sensor Location fix in Scope. Added FIA CAN 4 allowance to pins 17-20 of Scrut connector. 3.1.3 Image updated to remove internal antenna reference.
V1.5.0	Scope Image, readded torque sensor to rear. Section 3.1.7: Add labeling requirement to USB/Diag ports
V1.5.1	3.2.19 can→CAN Wiring diagram formatting update
V1.5.2	3.1.2 XAP brightness control 0-255 interpolation description updated.
V1.5.3	3.1.7 USB/Diag port labeling requirements updated; port picture updated
V1.5.4	3.2.18 Throttle Pedal Calibration Instructions added.
V1.5.5	3.2.18 Corrections to Throttle Pedal Calibration Instructions Step 3
V1.5.6	3.2.8 Torque Sensor Analog Input requirement 4.1.7 PPU Test Mode Function Description update
V1.5.7	Updated Cost Sheet

*© All rights reserved by Bosch Engineering GmbH,  
also for the case of patent reports. All rights such  
as copying and forwarding through us.  
Modifications reserved.*



**BOSCH**