



One Daytona Blvd.  
Daytona Beach, FL 32114  
P: +1 (386) 310-6500



# TECHNICAL BULLETIN

## IWSC TECHNICAL BULLETIN #25-76

To: All IMSA WeatherTech SportsCar Championship Participants  
From: IMSA Competition  
Date: September 15, 2025  
Re: GTP Sentronics System Test: Indianapolis Event

---

Please find the attached Bulletin and Documentation from IMSA and Sentronics on the following pages.

IMSA IWSC CUSTOMER BULLETIN  
 APPLICABLE CLASSES: GTP ONLY  
 2025 INDIANAPOLIS “CONNECT” RIG FLOW SYSTEM TESTING  
 15 September 2025

Sentronics, in collaboration with IMSA and Mansol, has developed a bespoke networking solution designed to record and transmit fuel transaction data for IWSC Race Events.

A successful proof-of-concept prototype was tested in November 2024 at Daytona. During the Indianapolis Event, Sentronics and IMSA will test updated hardware and software enhancements to support improved networking and seamless data integration with IMSA’s race data systems. This additional testing will span the entire Indianapolis Race Event and operate in parallel with the existing “RedBox” solution and architecture.

Please see below for a system overview.

### Indianapolis Data Topology/Connectivity

*sentronics*  
CONFIDENTIAL

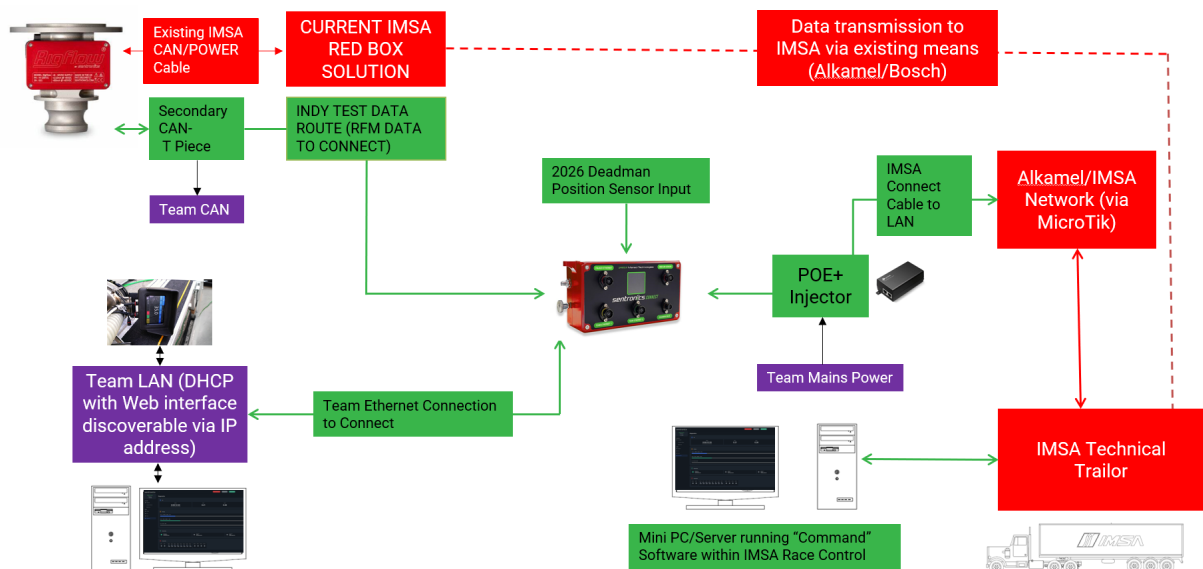

Participation is required only from the GTP classes for this Race Event.

The testing we plan to conduct has been planned to cause minimal disruption to teams, but will require the following:

- Installation of additional network cables
- Deployment/Installation of our “Connect” hardware
- Powering a POE+ injector, which will be supplied by Sentronics

Additionally, we will offer a Deadman Position Sensor (DPS) and installation bracket for any team that wishes to include it during the Indianapolis Event. This is entirely optional.

Trackside support engineers will be available from Thursday, the 18th, to assist with any issues and to deliver and install the required kit.

See below for a list of hardware to be supplied to teams:



Hardware to be supplied for the test by Sentronics:

1x T-piece CAN harness to retrieve data from secondary RFM CANbus without impacting team data.

1x Sentronics "Connect"

1x DPS Sensor and mounting bracket (HI-700-01)

1x POE+ injector

1x Connect Breakout cables to Team ethernet

1x Connect Breakout cable to IMSA ethernet.

Hardware Requirement from teams:

1x US kettle lead to power POE+ injector (And power at location of Connect)

2x 3M+ Ethernet Cables (Cat6 or Cat6a)

Optional Deadman Sensor Integration:

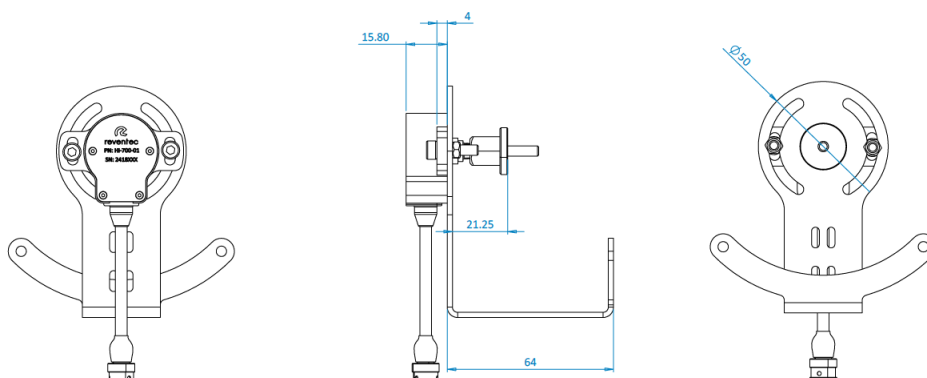

Sentronics will have all bracketry to accommodate all three variants of dead man valve assembly and can add this to your Deadman valve on Thursday.

Any questions please contact

[support@sentronics.com](mailto:support@sentronics.com)

or phone/WhatsApp Jamie Jones (+44 7990 883761)

Sentronics personnel will be present at INDIANAPOLIS and can be reached on site as follows:

Contact	Dates	Mobile	Email
Neville Meech	Wed-Sunday	+44 7900 997524	njm@sentronics.com
Jamie Jones	Wed-Sunday	+44 7990 883761	jjj@sentronics.com