



2026 TECHNICAL REGULATIONS

Revision Date: 12/17/2025

Series:

IMSA VP RACING SPORTSCAR CHALLENGE

Class:

LE MANS PROTOTYPE 3

Sanctioned by:

**INTERNATIONAL
MOTOR SPORTS
ASSOCIATION**

One Daytona Blvd.
Daytona Beach, FL 32114
(O) +1 (386) 310-6500
(F) +1 (386) 310-6695
www.imsa.com

Table of Contents

Foreword:	3	7.11.	Drive System	12
ARTICLE 1. DEFINITIONS SPECIFIC TO THE TECHNICAL REGULATIONS	6	7.12.	Cooling System	12
ARTICLE 2. TECHNICAL PHILOSOPHY	6	7.13.	Fuel System	12
2.1. Technical Eligibility	6	7.14.	Brake System	13
2.2. Changes	7	7.15.	Steering System	13
2.3. Conflict Resolution	7	7.16.	Suspension System	13
2.4. Final Authority	7	7.17.	Wheels & Tires	14
2.5. Conditions for Use of a Specific Homologation	7	7.18.	Electronics	14
ARTICLE 3. TECHNICAL TESTING AND VERIFICATION	7	ARTICLE 8. SERIES REQUIRED ELECTRONICS	15	
3.1. Reference Components	7	8.1. General	15	
3.2. Technical Testing	7	8.2. Series Scrutineering Data System	15	
ARTICLE 4. BALANCE OF PERFORMANCE	8	8.3. Safety Light System	15	
4.1. Balance of Performance	8	8.4. Driver ID System	16	
ARTICLE 5. SAFETY	8	8.5. X2 Transponder System	16	
5.1. Driver Safety Harness System	8	8.6. Leader Light System	17	
5.2. Seat	8	8.7. Back-lit Panel	17	
5.3. Driver Containment Nets	8	8.8. Pro-Am Light	17	
5.4. Protective Padding	8	8.9. Rain Light	17	
5.5. Protective Shielding	9	8.10. In-Car Camera	17	
5.6. Master Electrical Switches	9	8.11. Incident Data Recorder	17	
5.7. Fire Suppression System	9	ARTICLE 9. SCRUTINEERING FUEL COLLECTION	18	
ARTICLE 6. DEFINITION OF CLASS	9	9.1. Scrutineering Fuel Collection	18	
6.1. LMP3	9	ARTICLE 10. ENDURANCE EVENT REFUELING	18	
ARTICLE 7. VEHICLE SYSTEMS	9	10.1. General	18	
7.1. General	9	10.2. Autonomous Tank	18	
7.2. Modifications to the Specification	10	10.3. Peripheral Connections	19	
7.3. Servicing, Repair, and Replacement	10	10.4. Refueling Hoses	20	
7.4. Dimensions	10	10.5. Tank Support Stand	20	
7.5. Chassis	10	10.6. Boom	21	
7.6. Driver Interface	11	10.7. Refueling Restrictor	21	
7.7. Bodywork	11	10.8. Autonomous Tank Sensor System	21	
7.8. Aerodynamic Elements	11			
7.9. Engine System	11			
7.10. Boost Management	12			

Foreword:

For all Members, the IMSA RULES of the International Motor Sports Association establish the foundation for the organization and conduct of all IMSA Sanctioned Events. The IMSA RULES take effect immediately upon publication.

The purpose of the RULES is to: (i) promote safety, the sport of automobile Competition and IMSA, (ii) enhance Competition, (iii) ensure the quality, fairness and integrity of the IMSA programs and operations and (iv) achieve prompt finality in the Competition results (“**Purpose**”).

ALL MEMBERS ARE REQUIRED TO REVIEW THESE IMSA RULES CAREFULLY.

The **IMSA RULES** consist of following three (3) sections and the Event Supplementary Regulations (**SR**):

- The Technical Regulations, which outline the rules and regulations for the specific cars and equipment. The Technical Regulations may be modified or changed at any time by the publication of a Technical Bulletin, amending the Technical Regulations.
- The IMSA Sporting Regulations (**ISR**), which concern Competitor and Event procedures, as well as guidelines for the safe and uniform operation of the sport. The ISR may be modified or changed at any time by the publication of a Competition Bulletin, amending the ISR.
- The Series Supplementary Regulations (**SSR**) that provides Series-specific information about each IMSA Series. The SSR is integrated into the ISR and are designated with “(SSR)” next to the Paragraph title. The SSR may be modified or changed at any time by the publication of a Competition Bulletin, amending the SSR.

Any portion of the RULES may be modified through Bulletins (Competition Bulletins and Technical Bulletins, respectively) and takes force when published. Once published, the Bulletin shall take precedence over the applicable portion of the RULES. Additionally, the RULES may be modified for an Event by the Race Director through the mandatory briefing instructions.

HOW TO READ THE RULES

IMSA Technical Regulations for all Classes of the IMSA Prototype Challenge follow a common philosophy. The IMSA Technical Regulation philosophy can be summed in the following concepts:

- Cars are constructed and regulated to a controlled standard, the vehicle Homologation.
- Modifications to the Car are not permitted unless specifically stated in the applicable class’s Technical Regulations.
- The Car, at all times, must adhere to:
 - The current Homologation Document(s) and valid extension documents (e.g., EVO).
 - The Manufacturer’s or Constructor’s Parts Manual (where applicable by the RULES).
 - Manufacturer submitted and IMSA approved declarations (where applicable).
 - The IMSA Technical Regulations for the Class
- Normal adjustment of the Car is permitted as defined by the applicable Car’s Homologation and Class’s Technical Regulations.
- Repair of the Car, parts, and components is permitted, provided it serves no additional purpose other than the repair itself. All such repairs must meet all Constructor / Manufacturer specifications and regulatory requirements.

(cont.)

Modifications by an Entrant to parts, systems, and/or components of the Car is not permitted for any reason. An Entrant wishing to perform any modification(s) must present modification(s) to the applicable Manufacturer or Constructor for formal approval from the applicable Homologating Authority for the Class. Entrants are not permitted to work directly with a Homologating Authority(s).

Entrants must have a current copy of the applicable Homologation for their Car Model at all times, as well as full access to the Manufacturer's / Constructor's Part Manual. Both of these documents together clearly identify the compliant specification of the Car and will be used as reference materials for both the Entrant and IMSA (where applicable by the RULES). A copy of the Homologation may be provided by the applicable Manufacturer / Constructor or purchased from the Homologating Authority.

IMSA's regulations work in conjunction with Homologation regulations from a Homologating Authority. This sometimes creates conflicts across the various regulation sets. Often the Homologating Authority has a combined set of Technical and Homologation regulations.

The hierarchy of these various regulations applies in descending order is as follows:

1. IMSA Class Technical Regulations and Bulletins
2. These IMSA Technical Regulations shall govern in any case where a conflict exists with the Homologation Regulations and Documentation.
3. Homologation Authority Technical Regulations and corresponding Homologation Form.

Example 1: Incorrect process

A Team has found that a suspension part of the Car is prone to failure when going over large bumps. The Team chooses to resolve the problem on their own and modifies the part with components made in their own shop, which are not in the Homologation or Parts Manual of the Car. IMSA Technical Staff find this modification during a post-Race inspection. IMSA finds that the car is not in the approved configuration and the Entrant is penalized.

Example 2: Correct process

A Team suspects a part on the Car may be prone to failure during longer races. The Team therefore informs their Manufacturer or Constructor representative of their concern. The Manufacturer or Constructor agrees that a modification or redesign is appropriate and submits a written proposal with supporting documentation to the Homologating Authority for review. Upon approval the Homologation documents are updated and distributed for equitable customer awareness and part implementation.

Homologation Authority for each Class:

Class	Homologating Authority
P3	ACO

EXECUTIVE LEADERSHIP MASTHEAD

John Bishop* / Bill France, Sr.*

Founders – IMSA

Dr. Don Panoz*

Legacy Vice Chairman

Jim France

Chairman

Lesa Kennedy

Director

Ed Bennett

Chief Executive Officer

John Doonan

President

Amanda Oliver

General Counsel

Simon Hodgson

Senior Vice President, Competition

Brandon Huddleston

**Vice President, Partnership Marketing
and Business Development**

*Deceased

ARTICLE 1. DEFINITIONS SPECIFIC TO THE TECHNICAL REGULATIONS

- 1.1.1. **Car** means a singular representation of a Car Model, entered by an Entrant in an Event.
- 1.1.2. **Car Model** means a specific model of a vehicle constructed by an IMSA-recognized Manufacturer Partner, and intended for Competition.
- 1.1.3. **Class** means a category for Cars sharing a common set of Homologation Regulations and differentiated from others by type of Car Model.
- 1.1.4. **Competition** means a contest of competitive nature in which a Car takes part during an Event and results of which Competition are published.
- 1.1.5. **Constructor** means an entity that designs and builds race car chassis.
- 1.1.6. **Entrant** means an entity or person who has entered a Car that has been accepted for Competition and holds an IMSA Membership in the capacity of an Entrant or Entrant/Driver.
- 1.1.7. **Event** means an IMSA Sanctioned motorsport activity. It includes the designated Race as well as all periods for registration, inspections, practice Sessions, qualifying Sessions, racing, pre- and post-Race activities and inspections, and rain or postponed dates related thereto.
- 1.1.8. **Homologate** means to execute the Homologation Process.
- 1.1.9. **Homologated** means a Car Model approved through the Homologation Process.
- 1.1.10. **Homologation** means the concept of all things associated with Homologation Authority approval via the Homologation Process.
- 1.1.11. **Homologation Authority** means an entity with the authority to Homologate.
- 1.1.12. **Homologation Documentation** means all files, documents, information, and communication associated with the issuance of official approval of Homologation.
- 1.1.13. **Homologation Identifier** means the unique identifier (generally including a string of characters identifying the Category or Class of Homologation followed by a sequential number assigned to the Car Model) serving as a reference to the official approval of Homologation, assigned by the Homologation Authority.
- 1.1.14. **Homologation Process** means all procedures associated with petitioning a Homologation Authority for approval that a Car Model complies with the Homologation Regulations.
- 1.1.15. **Homologation Regulations** means a set of technical requirements and criteria used to design, construct, and document a Car Model intended for racing in a specific category or class of racing.
- 1.1.16. **Manufacturer** means a Manufacturer Partner constructing an approved Car Model.
- 1.1.17. **Manufacturer Partner** means a recognized IMSA Official Automotive Partner.
- 1.1.18. **Specification** means all technical characteristics of the Car Model defined by the Homologation and Technical Catalog.
- 1.1.19. **Specific Homologation** means the Homologation specific to a particular Car Model.
- 1.1.20. **Technical Catalog** means IMSA's collection of data and documents supporting a Car Model
- 1.1.21. **Technically Eligible** means conforms to all technical requirements and criteria defined by these Technical Regulations.

ARTICLE 2. TECHNICAL PHILOSOPHY

2.1. Technical Eligibility

- 2.1.1. Cars representing a Car Model must always respect the Specification.
- 2.1.2. To be eligible for participation in this Class, a Car Model must:
 - a. Be a Car Model constructed by an IMSA-recognized Manufacturer Partner.
 - b. Hold a valid Homologation, approved and issued by an IMSA-recognized Homologation Authority.
- 2.1.3. IMSA is the sole authority to define the Technical Eligibility of a Car Model and issue the Technical Credential.

2.2. Changes

- 2.2.1. Changes to the Specification are prohibited, unless explicitly authorized by IMSA.
- 2.2.2. Manufacturers alone are permitted to petition IMSA to change the Specification; requests by Entrants are not recognized.
- 2.2.3. **IMSA retains sole authority to accept change(s) and/or update(s) to a Homologation (e.g. Variant Option, EVO, etc.) within fourteen (14) days of load in for an Event.**

2.3. Conflict Resolution

- 2.3.1. These IMSA Technical Regulations shall govern where a conflict exists with the Homologation Regulations and Documentation.

2.4. Final Authority

- 2.4.1. IMSA is the Final Authority with respect to these Technical Regulations.

2.5. Conditions for Use of a Specific Homologation

- 2.5.1. At all times during IMSA-sanctioned Events it is the Entrant's responsibility to ensure the configuration of the Car Model represents the Homologation components of the Specification; including:
 - a. As-Homologated Configuration
 - b. Homologation Extension Form Configuration
- 2.5.2. IMSA, in its sole discretion, may consider the Parts Manual and/or the As-Delivered condition for additional detail of parts or equipment not adequately detailed in the Homologation. Inclusion of parts or equipment in the Parts Manual and/or the As-Delivered condition does not explicitly permit their use.
- 2.5.3. The original, As-Homologated Configuration of the Car Model must not be modified unless permitted by these Technical Regulations.
- 2.5.4. The As-Delivered Configuration of a Car must respect the as-received configuration from the Car Model Manufacturer, unless permitted by these Technical Regulations.
- 2.5.5. The Parts Manual is the official parts catalogue for the Car Model as defined by the Car Model Manufacturer or Constructor:
 - a. Specific parts listed in the Parts Manual must be used on all representations of a Car Model unless permitted by these Technical Regulations.
- 2.5.6. To be eligible for use in any IMSA-sanctioned Event, modifications detailed in Homologation Extension Forms must:
 - a. Be approved by, or have initiated the process to obtain approval from, the Homologation Authority, and appended to the Car Model Homologation.
 - b. Be approved by IMSA.
 - c. Be available to all Entrants of the relevant Homologated Car for the next Event.

ARTICLE 3. TECHNICAL TESTING AND VERIFICATION

3.1. Reference Components

- 3.1.1. IMSA may request Manufacturers submit reference components, tooling, and/or templates to the IMSA Technical Department.
 - a. IMSA may retain these components without compensation.
 - b. Manufacturers are responsible for all costs as related to submitting reference components.
 - c. Fees may apply.

3.2. Technical Testing

- 3.2.1. Testing conducted by IMSA; may be performed; including, but not limited to:

- a. Restrictor Flow
- b. Engine Dyno
- c. Wind Tunnel
- d. On-track Testing
- e. Refueling Testing

ARTICLE 4. BALANCE OF PERFORMANCE

4.1. Balance of Performance

- 4.1.1. Not Applicable

ARTICLE 5. SAFETY

5.1. Driver Safety Harness System

- 5.1.1. As Homologated
- 5.1.2. Installation must be performed in accordance with instructions provided by the system supplier and/or manufacturer.
 - a. Belt components must be installed at each anchor point to prevent accidental release or opening.
 - b. Individual belt straps must be independent; any method or attempt to combine individual straps is prohibited.
 - c. Elastic retention straps are prohibited on shoulder belts.
- 5.1.3. Harnesses must be replaced at the request of IMSA, or whenever the following conditions occur:
 - a. Expiration:
 - i. FIA Homologated: Immediately following December 31st of the year printed on the label.
 - ii. SFI Certified: Immediately following December 31st two (2) years after the year of Manufacture.
 - b. Damage:
 - i. Following a severe collision.
 - ii. Webbing is cut or frayed or weakened due to actions of chemicals or sunlight.
 - iii. Buckles are bent, deformed, rusted, or improperly functioning.
- 5.1.4. Entrants are responsible for ensuring the Driver safety harnesses and all associated components are properly labeled, installed, used, and maintained.

5.2. Seat

- 5.2.1. As Homologated.
- 5.2.2. Seat Inserts
 - a. Seat insert materials must respect either:
 - i. [FIA Technical List 50](#)
 - ii. [SFI Specification 45.2](#)

5.3. Driver Containment Nets

- 5.3.1. Not Applicable

5.4. Protective Padding

- 5.4.1. Cars must be equipped with non-flammable protective padding with a valid label demonstrating compliance with one of the following standards:
 - a. FIA Standard 8857-2001: FIA Roll Cage Padding Standard
 - i. [FIA Technical List #23](#): Roll Cage Padding Homologated by the FIA
 - b. SFI Specification 45.1: Roll Cage Padding

- i. [Specification](#)
- ii. [Manufacturers](#)

5.4.2. Installation requirements:

- a. Padding must be located to protect the Driver (body and/or helmet) against direct contact with the safety cage in a collision.
- b. Protective padding must be securely affixed to prevent rolling or displacement.

5.5. Protective Shielding

5.5.1. As Homologated

5.6. Master Electrical Switches

5.6.1. As Homologated

5.6.2. Interior and exterior master switches must be clearly identified by a self-reflective symbol of a red spark surrounded by a white-edged, blue triangle with a base greater than 30 mm.

5.7. Fire Suppression System

5.7.1. As Homologated

5.7.2. Identification

- a. Exterior activation mechanism must be marked with a self-reflective symbol with a red edge surrounding a red "E" inside a white circle at least 100 mm in diameter.

5.7.3. Inspection

- a. IMSA may require removal of the fire bottle for Technical Inspection.
- b. Entrant is responsible to demonstrate proper system function of the interior and exterior fire suppression activation mechanisms, using the "test" mode if present.

ARTICLE 6. DEFINITION OF CLASS

6.1. LMP3

6.1.1. Class Structure: 2020 **Homologation (GEN 2)** and ~~newer~~ **2025 Homologation (GEN 3)** LMP3 cars compete in the P3 Class of the IMSA VP Racing Challenge (VPRC).

6.1.2. Eligibility Requirements: To be eligible for participation in the Class, a Car Model must respect the Specification defined by the Homologation and Technical Eligibility requirements:

a. Homologation (LMP3):

Homologation Authority:	Automobile Club de l'Ouest (ACO)
Homologation Specification:	Automobile Club de l'Ouest (ACO) LMP3
Homologation Regulations:	2024 Technical Regulations for LMP3 Prototypes (GEN 2 Cars) 2026 Technical Regulations for LMP3 Prototypes (GEN 3 Cars)

ARTICLE 7. VEHICLE SYSTEMS

7.1. General

7.1.1. All Vehicle Systems and associated sub-systems are listed in this Article.

- a. Where change to the Homologated Vehicle Systems is permitted, regulatory text is **bold and underlined**.
- b. Where change to the Homologated Vehicle Systems is prohibited, regulatory text is light grey.
- c. Advisory statements are in normal text.

7.2. Modifications to the Specification

- 7.2.1. Entrants are permitted to execute the following changes to parameters defined by the Homologation component of the Car Model Specification, provided these Technical Regulations, all current Technical Bulletins, and the Technical Credential are fully respected:
 - a. Adjust component settings defined as adjustable.
 - b. Replace components with parts defined as optional.
- 7.2.2. Manufacturers must make any declarations listed in these Technical Regulations in the **Technical Eligibility Form**.
- 7.2.3. Further authorization to modify the Specification and/or As-Delivered Condition is granted via the following formal communication methods:
 - a. Published IMSA Technical Bulletin
 - b. IMSA Technical Committee Bulletin
- 7.2.4. Informal and/or verbal communication is not considered valid authorization.

7.3. Servicing, Repair, and Replacement

- 7.3.1. All servicing or repair must be made in good faith to restore the Car and all components to their originally intended form and function as defined by the Specification.
- 7.3.2. Entrants are permitted to replace damaged or worn components provided these Technical Regulations are respected.

7.4. Dimensions

- 7.4.1. General
 - a. IMSA's calibrated measurement instruments are the official measurement instruments.
- 7.4.2. Reference Surface
- 7.4.3. **Mass**
 - a. **The minimum mass for GEN 2 Car Models is 950 kg.**
 - b. **The minimum mass for GEN 3 Car Models is 1000 kg.**
 - c. Car mass is measured as-raced minus Driver and Fuel using the IMSA scales during Technical Inspection.
- 7.4.4. Ballast
 - a. **Entrants are permitted to add or remove ballast to achieve minimum mass:**
 - i. Ballast must be in plate or panel form.
 - ii. Addition or removal of ballast during the race is prohibited.
- 7.4.5. Ground Clearance
- 7.4.6. Overall Dimensions
 - a. Length
 - b. Width
 - c. Height
 - d. Wheelbase
 - e. Track
 - f. Overhang
 - g. Width

7.5. Chassis

- 7.5.1. General
 - a. **Entrants are permitted to execute minimum modifications for the installation of mandated components.**
 - i. All modifications must be approved by IMSA.
- 7.5.2. Air Jack System

7.6. Driver Interface

- 7.6.1. General
- 7.6.2. Steering Wheel
- 7.6.3. Pedal Box
 - a. Entrants are permitted to apply non-slip adhesives to the surface of driver pedals.
- 7.6.4. Shifting Mechanism
- 7.6.5. Driver Adjustable Components
- 7.6.6. Driver Cooling Systems

7.7. Bodywork

- 7.7.1. General
 - a. Entrants are permitted to install the following films to the front windscreen:
 - i. Tear-off
 - ii. Anti-fog
- 7.7.2. Bodywork Seams
 - a. Entrants are permitted to apply tape or vinyl around refueling receptacle seams and/or rear wing end fence adjustment holes.
- 7.7.3. Decals
 - a. Entrants are permitted to apply removable die cut sponsorship decals with the approval of IMSA.
 - b. Windows must remain free of decals and/or tint unless required by IMSA

7.8. Aerodynamic Elements

- 7.8.1. General
- 7.8.2. Splitter
- 7.8.3. Dive Planes
- 7.8.4. Body Gurney
- 7.8.5. Wings
- 7.8.6. Rear Wing Gurney
- 7.8.7. Floor
- 7.8.8. Friction Blocks
- 7.8.9. Diffuser

7.9. Engine System

- 7.9.1. General
 - a. Manufacturer seals must be respected
- 7.9.2. Engine
 - a. **GEN 2** - The permitted engine is the Oreca VK56.
 - b. **GEN 3 - As Homologated**
- 7.9.3. Lambda
- 7.9.4. Oiling System
 - a. Approved lubricants are permitted to be utilized.
- 7.9.5. Engine RPM

- 7.9.6. Intake
- 7.9.7. Exhaust
- 7.9.8. Turbo
- 7.9.9. Engine Control Unit (ECU).

7.10. Boost Management

- 7.10.1. Maximum Boost Pressure
- 7.10.2. Boost Pressure Ratio
- 7.10.3. Boost Control Strategy Inputs
- 7.10.4. Calculation Method

7.11. Drive System

- 7.11.1. General
 - a. As Homologated
- 7.11.2. Fluids & Lubricants
 - a. **Unrestricted.**
- 7.11.3. Clutch
 - a. **GEN 2** - Entrants are permitted to utilize the Oreca VK56/VK50+ Clutch Evo Kit.
 - b. **GEN 3 - As Homologated**
- 7.11.4. Gearbox
- 7.11.5. Gears
- 7.11.6. Gearbox Control Unit
- 7.11.7. Differential
- 7.11.8. Axles
- 7.11.9. Uprights

7.12. Cooling System

- 7.12.1. General
- 7.12.2. Fluids
 - a. **Entrants are permitted to utilize the following approved cooling fluids:**
 - i. Water
 - ii. Air
 - iii. Non-glycol based fluids
- 7.12.3. Inlet Blockers
- 7.12.4. Water System
- 7.12.5. Oil Cooling System

7.13. Fuel System

- 7.13.1. General
 - a. Maximum Capacity
 - i. The maximum fuel system capacity for all cars is 100 liters.
 - ii. The maximum fuel capacity is the total volume of fuel contained in the Car.

7.13.2. Fuel Types

- a. The approved fuel for the Class is IMSA E10, as supplied by VP Fuels.
 - i. IMSA may require a fuel sample for inspection via a gas chromatograph.

7.13.3. Fuel Cell

- a. **Entrants must use blocks or balls to achieve maximum fuel system capacity**
 - i. Any device, system, or procedure to increase, even temporarily, the total fuel storage capacity beyond the maximum is prohibited.

7.13.4. Fuel Lines

7.13.5. Fuel Sample Port

7.13.6. Refueling Receptacle

- ~~a. **During Practice and Qualifying Sessions, Entrants are permitted to install and utilize an ATL dry break for the purpose of adding fuel to the Car.**~~
 - ~~i. **ATL dry break and associated equipment must be removed from the Car during the Race.**~~

7.14. Brake System

7.14.1. General

7.14.2. Fluids & Lubricants

- a. **Unrestricted.**

7.14.3. Bias Assembly

7.14.4. Master Cylinders

7.14.5. Brake Lines

7.14.6. Calipers

7.14.7. Rotors

7.14.8. Pads

7.14.9. Ducting

7.14.10. Brake Duct Inlet Blockers

- a. **Entrants are permitted to apply opaque adhesive tape to block off portions of the brake duct inlet openings.**

7.14.11. Anti-Lock Braking System

7.15. Steering System

7.15.1. General

7.15.2. Fluids & Lubricants

- a. **Unrestricted.**

7.16. Suspension System

7.16.1. General

7.16.2. Geometry Elements

7.16.3. Springs

- a. **Entrants are permitted to change primary spring rates:**
 - i. The As-delivered number of springs per wheel must be respected.

7.16.4. Dampers

- a. Dampers must be utilized with valving and internals as per the applicable Constructor's IMSA Technical Credential.
- b. Dampers must be used with intact seals.
- c. Dampers must be unmodified from the approved rebuilding and sealing vendor. The approved rebuilding and sealing vendor is:

Chassis Constructor	Damper	Address
Ligier, Duqueine, Ginetta, Adess	Ohlins	Ohlins North America Attn: LMP3 Service 703 Grove Street Hendersonville, NC 28792

- d. Entrant is responsible for all costs associated with the sealing program, including seals, inspections, labor, shipping, and handling.
 - i. Entrant is responsible for shipping to the approved rebuilding vendor with adequate time for the vendor to perform the required service.
- e. Dampers must be identified with car number when in use and when being sealed.

7.16.5. Bump Rubbers and Packers

- a. **Unrestricted.**

7.16.6. Anti-Roll Bar

7.16.7. Third Elements

7.17. Wheels & Tires

7.17.1. General

7.17.2. Wheels

7.17.3. Wheel Attachment

7.17.4. Tires

- a. The approved tire supplier for this Class is Michelin.
- b. Tires must be used in accordance with SSR Attachment 3.

7.18. Electronics

7.18.1. General

a. Driving Camera

- i. **Entrants are permitted to install a "Connected" camera system mounted per the applicable Car Model's Homologation.**
- ii. Entrants are permitted to install a stand-alone camera as a substitute to the "Connected" camera system.
 - (i) Stand-alone camera must be installed in the Homologated location.

b. Lap Timer

- i. **Entrants are permitted to install a lap timer.**
- ii. Lap timer must be mounted per the applicable Car Model's Homologation.

c. Pitlane Timer

- i. **Entrants are permitted to install a pitlane timer.**
- ii. Pitlane timer must be mounted in the space defined for the lap timer in the applicable Car Model's Homologation.

d. GPS Antenna

- i. If any permitted equipment uses a GPS antenna, the antenna must be mounted no less than 75 cm away from the mandatory GPS antenna.

7.18.2. Data Logger

- a. IMSA reserves the right to download and/or view all logged data at any time.
- b. Any such equipment must be correctly mounted and in place for pre-event scrutineering.
- c. Any electronic device liable to interfere with the proper function of the on-board electronics (included but not limited to ECU, Data logger, ADR, GPS antenna) is forbidden.
- d. IMSA may at any time ask for removal of any electronic equipment if it is deemed to pose a safety problem or if it interferes with the mandatory electronic equipment.

7.18.3. Telemetry**7.18.4. Wiring Loom****7.18.5. Sensors****7.18.6. Radio**

- a. **Entrants are permitted to install a single two-way voice radio with car-to-pit communication capability in compliance with the corresponding Series Sporting Regulations.**

7.18.7. Rear View Camera**7.18.8. Tire Pressure Monitoring System (TPMS)**

- a. **Entrants are permitted to install a Tire Pressure Monitoring System (TPMS).**
 - i. The homologated mounting position(s) must be respected.

ARTICLE 8. SERIES REQUIRED ELECTRONICS**8.1. General**

- 8.1.1. All Series required electronics must be installed per the applicable Homologation and/or Declaration.
- 8.1.2. Entrant is responsible for the operation, maintenance, and care of Series required electronics.

8.2. Series Scrutineering Data System

- 8.2.1. Cars must be equipped with an IMSA-supplied data logger when requested.
 - a. Cars must have a dedicated 12 V power lead to install the IMSA-supplied data logger.
 - b. Power lead shall remain on as long as the master kill is switch is on.

8.3. Safety Light System**8.3.1. Sprint Race Configuration**

- a. Cars must be equipped with an approved Yellow Light Kit to indicate active flag status, purchased from the approved supplier. System options as follows:
 - i. Option #1 - Standalone MSE

MSE Safety Light Receiver	Creative Motorsports Solutions
MSE Safety Light Kit	

- (i) The Kit contains the following components:
 - (ii) Safety Light Receiver
 - (iii) Yellow Indicator Light
 - (iv) Antenna
 - (v) Wiring Loom and Instructions

ii. Option #2 -XAP NTX Marshalling Display

XAP NTX Marshalling Display	Creative Motorsports Solutions
MSE Antenna Kit	
MSE Safety Light Receiver	

- b. The Safety Light system must be installed and functioning during on-track activity.
- i. The Yellow Indicator Light must be prominently installed within the cockpit, in clear line of sight of the driver.
 - ii. Antenna Installation: The supplied antenna must be mounted:
 - (i) On the Car roof
 - (ii) Away from other antennae
 - (iii) Following the diagram below (a ground plane is not required):

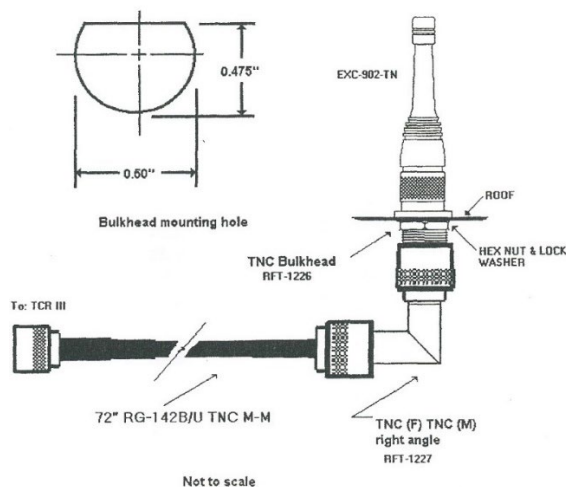

- c. Wiring Loom Installation: The Wiring Loom has a flying lead input for +12 VDC and Ground to interface with additional wiring referenced in the installation instructions.
- i. Entrants must supply additional wiring as required.

8.3.2. Endurance Race Configuration

- a. In addition to the Sprint Race Configuration components, Car must be equipped with the:
 - i. Base X2 Racelink Club Kit
 - ii. X2 LED Bar
- b. Ordering Information: [IMSA Electronics Ordering](#)

8.4. Driver ID System

- 8.4.1. Car must be equipped with the X2 Driver ID Club Kit.
 - a. Ordering Information: [IMSA Electronics Ordering](#)

8.5. X2 Transponder System

- 8.5.1. Cars must be equipped with the X2 Transponder System Kit.
 - a. X2 Transponder Kit contains the following component(s):
 - i. Transponder.
 - ii. Isolation Mounts.
- 8.5.2. X2 transponder must be purchased via [Creative Motorsport Solutions](#).

- 8.5.3. The transponder must be installed in the same location as the applicable Constructor has determined in the Scrutineering Homologation Document.
- 8.5.4. Transponder must be mounted using the mounting bracket with appropriate thermal protection in an area where the temperature cannot exceed 50 °C

8.5.5. The following components are required:

Constructor	Driver ID Module	Main Loom
Ligier	PV0176.03	3800-DI033A
Duqueine	PV0176.03	3800-DI039A
Ginetta	TBD	TBD
Adess	TBD	TBD

- 8.5.6. Minimum loom/harness ordering window is 8 weeks. Expedited fees may apply if ordering window is not respected

8.6. Leader Light System

- 8.6.1. Cars must be equipped with LED leader light panel system as follows:

- a. XAP
 - i. XAP Leader Light System # LPP-130
 - ii. XAP Harness
 - iii. Available from CMS (<https://www.gomuchfaster.com/products/imsa-xap-led-position-panel>)

- 8.6.2. Leader light system must be installed and functioning during the Event

- a. System must be installed in accordance the Manufacturer submitted, IMSA Approved, Series Electronics Declaration Form
- b. Series Electronics Declaration Form is available from the respective Manufacturer Partner.

- 8.6.3. Leader Lights consume less than 4.5 A (10-15 VDC), and must:

- i. Be a fused, 12-volt DC configuration
- ii. Meet the specifications defined by ISO 7637

8.7. Back-lit Panel

N/A

8.8. Pro-Am Light

N/A

8.9. Rain Light

8.10. In-Car Camera

- 8.10.1. See SSR 15 and SSR 16.

8.11. Incident Data Recorder

- 8.11.1. Entrants must utilize the FIA Impact Data Recorder (IDR)
- a. Must be installed in the Constructor defined location and consistent with Manufacturer orientation requirements.
 - b. IDR must be installed and functional for all on-track activity.
 - c. IMSA provides the IDR to the Entrant.
 - d. Data collected by the IDR is property of IMSA.
 - e. IDR must be surrendered upon request by IMSA.

ARTICLE 9. SCRUTINEERING FUEL COLLECTION

9.1. Scrutineering Fuel Collection

9.1.1. Fuel Collection Vessel must:

- a. Be non-opaque.
- b. Be free of any carriage or trolley system.
- c. Have a flat bottom.
- d. Rest without assistance on the IMSA scale for weight measurement before and after defueling the Car.

9.1.2. Fuel Pump Out Hoses

- a. Entrant must utilize 2 separate hoses for defueling activities:
 - i. Fuel drain
 - ii. Vent return
- b. Both hoses must connect the Car to the collection vessel.
- c. Must utilize dry-break connections to the Car and fixed (sealed) connections to the fuel collection vessel.

9.1.3. Fuel drain hose must have a clear section of no less than 250 mm near the collection vessel.

ARTICLE 10. ENDURANCE EVENT REFUELING

10.1. General

10.1.1. During Endurance Race Events in Pit Lane, fuel must be transferred from the autonomous supply tank to the Car using the equipment and methods defined in this Article.

- a. Approved equipment as defined herein must be:
 - i. Unmodified.
 - ii. Installed and operational.
- b. Approved method:
 - i. Gravity.

10.1.2. Fuel transferred to the autonomous supply tank must be delivered by means of a hose fitted with a self-sealing connector (e.g. dry break, cam-lock) connected to the autonomous supply tank.

10.2. Autonomous Tank

10.2.1. Construction of the Autonomous Supply Tank must:

- a. Comply with FIA Appendix J Article 257A Drawing n° 252-7 with the exception of the top plate shape and dimensions.
- b. Not have sensors other than as required by IMSA.

10.2.2. Refueling tank height is measured from the top surface of the vessel, not including vent, cover plate or fasteners, at a distance of 1.25 meters from the outermost face of the pit wall

10.2.3. The required Autonomous Tank heights are as follows:

- a. Teams utilizing an Autonomous Tank trolley (non scissor/X-brace style) are permitted to utilize a maximum height of 1.83 m (6 ft) with a tolerance of +0 cm.
- b. Scissor style (X-brace) stand height has a maximum height of 1.83 m (6 ft) with a tolerance of +0 cm.

10.3. Peripheral Connections

10.3.1. Tanks must be equipped with the IMSA-specified peripheral connections between the tank outlet and the refueling hose.

a. Parts must be purchased from RPXpress and used unmodified:

Part Number	Part	Description
BSR-FR FN40	Outlet Flange	Bottom Tank 12-bolt housing
ATL-TF 147	12-Bolt Gasket	2 Needed (Outlet and Vent Flanges)
BSR.FR.R.35GOLD	35.0mm Restrictor	Upper Restrictor (for positive seal to Elbow)
BSR-FR 1981	Bottom 80 deg. Elbow	Female Camlock x 2" Male
BSR.P.5K56.SS	Restrictor Housing	Deadman Outlet, 2" Male to 1 1/2" Camlock
BSR.P.5K.RPX.SS	Hose Coupler	1.5" OD barb to Deadman outlet
BSR-FR-R290	29.0 Refueling Restrictor	Deadman Outlet Restrictor (for positive seal to hose)
BSR.FR.DD	Discriminator	Rollover safety valve
BSR.FR.FN39	Vent mounting flange	Top surface mounting flange
1 Deadman Valve:		
BSR-FR-R003	Deadman Valve (new design)	Stainless Deadman Valve
BSR-FR-R002	Deadman Valve (old design)	Brass Deadman Valve

b. Alternate discriminator valve(s) and associated mounting flange(s) may be permitted by IMSA Officials.

c. Refueling System Assembly Illustration:

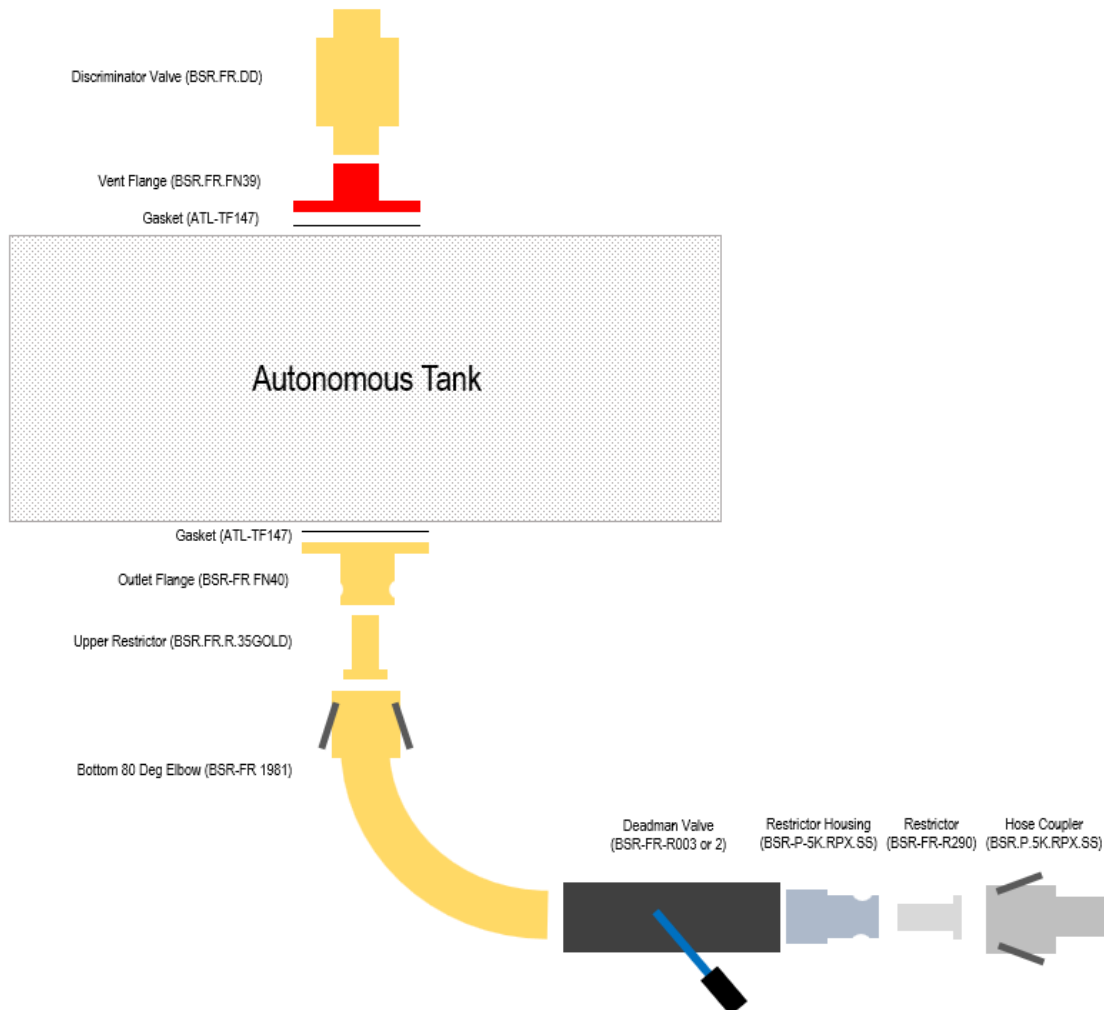

- 10.3.2. Deadman valve and bottom 80 deg. elbow assembly must be securely braced to remain attached to the tank in the event of an incident.
 - a. Mechanisms preventing normal operation of the deadman valve are prohibited.
- 10.3.3. During refueling the air vent outlet must be connected using an appropriate coupling to the tank.
- 10.3.4. A sight glass is permitted to be installed to the outside of the supply tank, and must be equipped with isolating valves mounted as close as possible to the tank.
- 10.3.5. Vent tube may be shaped to avoid interference with overhead obstruction(s), the minimum functional vent height of 1 m must be respected per FIA Appendix J Article 257A Drawing n° 252-7.
- 10.3.6. A foam-based spark arrester must be installed in the vent head and remain visible from the pit lane surface.

10.4. Refueling Hoses

- 10.4.1. Refueling/vent hoses must have one end equipped with a self-sealing connector to fit the autonomous supply tank outlet.
- 10.4.2. Refueling/vent hoses are permitted to be protected for the sole purpose of resisting abrasion damage.
 - a. Cover must be easily removable by means of full-length Velcro or zipper.
 - b. Cover must be non-reflective
- 10.4.3. Hose maximum inside diameter
 - a. Dual-Port systems must be less than 1.5 inches for all hoses.
 - b. Single-Port (coaxial) systems must be less than 1.5 inches for Refueling Hose and less than 75.0mm for the vent hose.
- 10.4.4. Refueling hose minimum length must be greater than 4.0 m
 - a. Minimum length is measured from the most distant plane of the dry break/fuel probe to the most distant plane of the Hose Coupler.

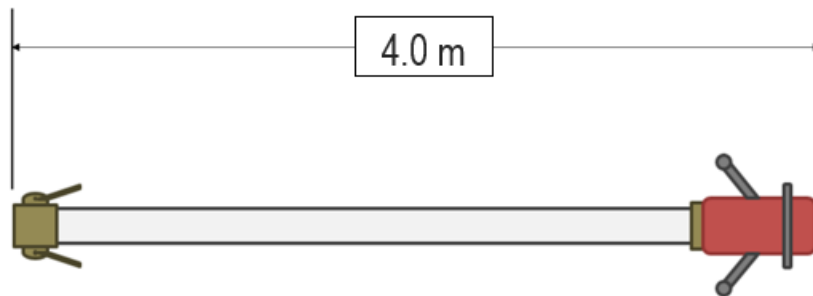

10.5. Tank Support Stand

- 10.5.1. The tank must be attached to one of the following:
 - a. To a trolley meeting the following requirements:
 - i. All tower components must be assembled without any degree of freedom in relation to the trolley.
 - ii. Have a surface area greater than two (2) square meters.
 - iii. Utilize four (4) self-braking casters.
 - iv. Be ballasted with weight exceeding that of the tank when filled with fuel.
 - b. Scissor style (X-brace) stand
 - c. Other apparatus as approved by IMSA
- 10.5.2. Tank Support Stand is permitted to have load sensors for the sole purpose of weighing fuel in the Autonomous Tank.
- 10.5.3. Tank Support Stand must have a minimum of two (2) support feet directly on the paved surface without the use of shims.
 - a. One shim is permitted to be added to support feet.
 - b. Shim(s) must have a greater area in contact with the ground than the foot.
 - c. Multiple shims are permitted to be used under a foot, provided:

- i. The shims are securely fastened together by means of bolts and/or screws.
- ii. The foot is securely attached to the shim by means of bolts/screws.
- iii. The assembled height of the shim must be safe to the satisfaction of IMSA Officials.

10.5.4. Tank Support Stand feet must be wider than the Autonomous Tank diameter.

10.5.5. Tank Support Stand setup and leveling assembly(s) must be secure to the satisfaction of IMSA Officials.

10.6. Boom

Not Applicable

10.7. Refueling Restrictor

10.7.1. During refueling, all fuel entering the Car must pass through the refueling restrictor.

10.7.2. Refueling restrictors must be purchased from RPXpress and used without modification (Phone: +1-828-428-0820 Email: Imcelwain@rpxpress.com).

- a. The mandatory Refueling Restrictor size is **29.0 mm**.
 - i. Restrictor must be used as-delivered from RPX.

10.8. Autonomous Tank Sensor System

Not Applicable