



FERRARI
CHALLENGE

TROFEO
PIRELLI



FERRARI
CHALLENGE

TROFEO
PIRELLI

NORTH AMERICA

2026

SPORTING AND TECHNICAL REGULATIONS

SPORTING REGULATIONS

1	Introduction.....	4	15	Signals and radio frequencies.....	15
2	General principles	4	16	Private practice / Test Sessions	15
3	Use of image - advertising and promotional activities	5	17	Official practice and qualifying	16
5	Drivers' requirements.....	7	18	Admission to the start, pre-grid, and starting grid	17
6	Admission of drivers.....	8	19	Race	17
7	Application form and entry fees.....	11	20	Safety car.....	18
8	Insurance	11	21	Parc fermé.....	18
9	Race length	12	22	Podium	19
10	Official schedule and supplementary race regulations.....	12	23	Standings and points	20
11	Sporting and technical scrutineering.....	12	24	Titles.....	20
12	Drivers' meetings.....	13	25	Incidents and driver conduct.....	21
13	Tires and fuel	13	26	Penalties and sanctions.....	21
14	General safety and pit regulations - paddock assignments.....	14	27	Protests and appeals	23
			28	Other situations	23

TECHNICAL REGULATIONS

1	Admitted cars.....	24	16	Lubricants	28
2	General Principles	24	17	Safety equipment	28
3	Minimum weight / height requirements	24	18	Video recording equipment and loggers.....	28
4	Engine	25	19	Telemetry / diagnostic tools.....	28
5	Electrical system	25	20	Organization of the assistance.....	29
6	Gearbox / transmission.....	25	21	Final instructions	29
7	Wheels / tyres	26			
8	Suspensions and setup	26			
9	Pipes / wiring / heat shields	26			
10	Frame and body.....	26			
11	Aerodynamics.....	27			
12	Cockpit.....	27			
13	Windshield and side windows	27			
14	Fuel.....	27			
15	Brake system	28			

ANNEXES

ANNEX 1	30
ANNEX 2	33
PROTECTIVE EQUIPMENT IMSA APPROVED.....	35
Tire Replacement Procedure.....	36
Car Replacement Procedure.....	37



1 Introduction

1.1 The Ferrari Challenge Trofeo Pirelli series (hereinafter "**Ferrari Challenge**") - is intended for the enjoyment of all its participants, and these regulations are written to support that intention. Ferrari Challenge entrants ("Drivers") are expected to compete in a spirit of fair play, with respect for these regulations, fellow competitors, and the cars. Drivers are expected to be competitors rather than combatants and to place the spirit of fair and safe competition ahead of finishing position. This standard applies to both on-track and off-track etiquette. Drivers who fail to respect this fair-play philosophy may be excluded from the series or from individual events at the discretion of the Challenge Committee or the Race Director at any time.

1.2 The 2026 Ferrari Challenge is organized by Ferrari North America and its authorized dealers and is sanctioned by the International Motor Sports Association (IMSA). Questions or concerns regarding the organization and logistics of the series should be addressed to Ferrari North America.

1.3 Submission of an entry application for the Ferrari Challenge constitutes an implicit undertaking by the Driver that he or she is familiar with and agrees to comply with the Ferrari Challenge Sporting and Technical Regulations ("**Ferrari Challenge Regulations**"), the IMSA Regulations, and any supplementary regulations or communications issued in connection with an event, whether distributed in the paddock or electronically. By submitting an entry, the Driver acknowledges IMSA as the sole competent jurisdiction, subject only to the rights of appeal expressly set forth in the IMSA Regulations and the Ferrari Challenge Regulations, that he or she thus undertakes not to submit suits to arbitrators or other jurisdictions on the basis of circumstances deriving from the organization or conduct of the event. The Driver releases IMSA, Ferrari S.p.A., Ferrari North America, its authorized dealers, the Organizers, the Promoter, the Race Officials, and the circuit owner FROM liability for injury, loss, or damage sustained by the Driver or the Driver's passengers, employees, or property. Drivers will be required to sign waivers to this effect.

1.4 Each Ferrari Challenge event shall be conducted under the authority of the Race Director, whose responsibilities include oversight of all on-track activities in accordance with the 2026 IMSA Regulations (see competitors.imsa.com) of the IMSA WeatherTech SportsCar Championship (IWSC). The Race Director may impose penalties pursuant

to the Ferrari Challenge Regulations, the IMSA Regulations, these specific Regulations, and any other regulations under which the Ferrari Challenge may be run. The Race Director's decisions are not subject to appeal in any race Ferrari North America organizes, regardless of the country.

1.5 Ferrari S.p.A., Ferrari North America, the Ferrari Challenge Series, and IMSA Officials reserve the right to modify or apply any of the regulations of the Ferrari Challenge at any time to ensure the safety, fairness, and success of the contest, or to cancel a portion of an event, an entire event, or the series should it become necessary. This group of entities will herein be referred to as the "Challenge Committee".

1.6 To operate a customer's car, a team must be officially licensed by both Ferrari North America and IMSA for the 2026 season, must pay all required credential fees and operate under all standards, both written and verbal, from Ferrari North America. Each entry must be affiliated with an Official Ferrari North America dealer, who will incur all billings for the Ferrari Challenge or Club Challenge programs. Each working team member must hold a valid 2026 Ferrari Challenge and IMSA credential. Each car entered must have a licensed Team Manager present at the track during all on-track sessions and is present at all meetings on the official timetable. Failure to comply with these requirements may result in exclusion from an event or from series participation.

2 General principles

2.1 The Ferrari Challenge is exclusively open to the 296 Challenge. All cars must meet the specifications stated in the Technical Regulations and specific technical documentation and conform to any updates as issued by Ferrari North America and/or other entities of the Challenge Committee.

2.2 All Cars must be registered with Ferrari Support prior to participation in any Ferrari Challenge activity. A series registration fee will be charged to all entrants at the beginning of the season and/or prior to a single race.

2.3 All preparation, maintenance, and service of Ferrari Challenge cars must be provided exclusively by Authorized Ferrari Dealers in North America ("Dealers"), or an authorized Team as indicated by an approved independent Team Application Form, submitted by the Dealer. Only teams



with a valid Ferrari Challenge North America license are eligible to operate in the paddock at each event.

2.4 All registered Drivers are eligible to participate in single races of any global Ferrari Challenge series (Europe, North America, Asia Pacific) subject to grid availability and approval by the Challenge Committee. Participation in events outside a Driver's home series must be coordinated through the applicable local Series Manager.

2.5 296 Challenge There will be four (4) categories competing for individual championships for the 2026 Ferrari Challenge season (P, P-AM, S, S-AM). The general guidelines for these classes are as follows, but the Challenge Committee (see Article 6.1) will determine each undefined driver as it is in the best interest and fair play of the series as defined in Article 6.

- Ferrari Challenge Trofeo Pirelli;
- Ferrari Challenge Trofeo Pirelli-AM;
- Ferrari Challenge Coppa Shell;
- Ferrari Challenge Coppa Shell-AM;
- Ferrari Challenge Ladies' Cup – if the Driver is a woman, she will also be given the opportunity to participate in the title of Ladies' Cup Champion (in both the Shell and Shell-AM classes);
- Ferrari Challenge Gentlemen's Cup – if the Driver is male, and over the age of 65, he will also be given the opportunity to participate in the title of Gentleman Driver.

2.6 The Challenge Committee may use any criteria to determine class assignment. All decisions by the Challenge Committee regarding assignment (and/or subsequent reassignment) are final and not subject to appeal. Classifications will only be made after the driver is entered to race.

2.7 The Challenge Committee reserves the right to change a Driver's categorization, which is typically evaluated after the driver has participated in two events. A Driver who is reclassified shall retain all points earned prior to reclassification, up to but not exceeding the points total of the class championship leader at the time of reclassification.

2.8 Drivers demonstrating sustained top-level performance in the Coppa Shell-AM, Coppa Shell, and Trofeo Pirelli-AM classes may be promoted to a higher class for the following season, at the discretion of the Challenge Committee.

3 Use of image – advertising and promotional activities

3.1 All rights relating to the name, trademark, and images of the Ferrari Challenge and of Challenge events as well as their use are the property of Ferrari, which may use them at its own discretion.

3.2 The following rights in particular are the sole property of Ferrari, which may use them without any limit of time or territory:

1. Rights to the production, use, and broadcasting via radio, television, film, home video, Internet, wireless, and related technologies, or any other platform, means, or system of transmission be it material or digital, existent, or future, using any terrestrial or satellite broadcasting or reception equipment, of the Ferrari Challenge and Challenge events; and
2. any rights to the use for any advertising, commercial, or promotional ends of the name, brand, and image of the Ferrari Challenge and Challenge events.

3.3 The Teams and Drivers acknowledge and accept that Ferrari reserves the right to use, either directly or indirectly, and to supply to third parties (including Ferrari sponsors and partners and Ferrari Challenge and Challenge event sponsors and partners), both in Italy and abroad, without any prior warning and without any of said parties receiving any compensation for the following:

1. The names, brands, images (moving and still), and results (rankings) of the Teams and Drivers taking part in the Ferrari Challenge and Challenge events, and
2. the images of the Car and the Drivers' overalls and/or helmets as well as the support/assistance vehicles, equipment, and anything else used by the Teams and Drivers during their participation in the Ferrari Challenge and Challenge events, complete with the names and/or logos of the sponsors (both of the Ferrari Challenge and Teams and Drivers), for advertising, commercial, and promotional ends. This includes producing and having produced merchandising articles (such as, for example, electronic games and scale models of the Car) and advertising and/or promotional material.

3.4 During all of the Ferrari Challenge events, the Car will have a livery made up of the following components:

1. the logos of the official and institutional sponsors of the Ferrari Challenge ("Coordinated Advertising"), as determined at the discretion of Ferrari, affixed in the positions and dimensions indicated on the official silhouette of the 296 Challenge;



2. the logos of the Teams' and Drivers' personal sponsors, determined on the basis of the present Regulations;
3. three number plates and their relative numbers, to be considered part of the Coordinated Advertising. The Drivers are required to retain unaltered and unobstructed Coordinated Advertising on their cars. Drivers are not permitted to add other symbols, logos, or anything else outside the authorized spaces. The number plates and numbers must be those provided by Ferrari.

3.5 The Ferrari Challenge – North America Coordinated Advertising will be as follows:

Sponsor - Commercial Category

Adler	Soundproofing for vehicles and interior coverings
AHE (Azimut)	Investment Fund
Ansys	Engineering Simulation Software
AT&T	Telecommunications
Akrapovic	Mufflers, catalytic converters
Bell	Helmets
Ceva	Logistics
Fage	Yogurt
Iveco	Trucks
Pennzoil	Fuel and Lubricant
Pernod Ricard	Spirits
Peroni	Beer
Pirelli	Tyres
PMI	Tobacco
Puma	Technical Apparel
Richard Mille	Watches
2 Elle Engineering	Wheels
Sabelt	Automotive Belts
San Pellegrino	Beverage
Salesforce	Software Development
Seven Beauties	Beauty and Beauty Management consulting
Shell	Fuel & Lubricants
Surpass Co.	Semiconductors
Thermal	Circuit Facility
TubiStyle	Mufflers, catalytic converters

If during the season the series signs on a new partner, all Teams are required to retrofit their equipment to feature the added livery aspects. Teams are required to inform Ferrari of any possible sponsorship opportunity and request from Ferrari a specific authorization, notwithstanding a potential conflict within the provisions of the present regulations.

3.6 Only the official Puma Race apparel may be worn (excluding helmet, HANS® device, and eject system) and must include fire-resistant undergarments.

3.7 Failure to comply with any provision contained in Article 3 may result in penalties as determined by the Challenge Committee, that can include exclusion from the rankings and/or the suspension of the Driver's competitive activities within the Ferrari Challenge (Europe, North America, Asia Pacific, United Kingdom, Middle East, Australasia and Japan).

4 Rights of the teams and drivers /
Rights of the teams' and drivers' sponsors and partners

4.1 Rights of the Teams and Drivers

1. Team name
Each Team shall bear the name of the Authorized Ferrari Dealer in North America for which the Driver is competing (see Articles 7.2 and 7.3).
2. Display of the Teams' and Drivers' sponsors and partner logos
The Teams and Drivers may display their sponsors' logos and/or those of personal partners on condition that the aforementioned:
 - a) are not in conflict with the Coordinated Advertising referred to in Article 3.5 or, in general, with Ferrari's own sponsors and/or partners; and
 - b) are not in conflict with Ferrari's sponsors and/or partners and/or in potential conflict with the interests of Ferrari's sponsors and/or partners (see Annex 1);
 - c) do not harm the image, prestige and reputation of Ferrari, of Ferrari's sponsors and/or partners and/or of the Ferrari Challenge in general;
 - d) have been submitted to the prior approval of Ferrari (see Article 4.5).
 Logos of the Teams' and Drivers' sponsors and partners may be displayed in compliance with the directives and/or instructions provided by Ferrari:
 - on the Cars;
 - on Team-owned official support vehicles used in the Ferrari Challenge;
 - on Drivers' racing overalls;
 - on official uniforms worn by the Teams' support staff;
 - on press releases issued by the Teams and relating to the Ferrari Challenge on condition that it is clear that the communication is the work of the Team and not Ferrari;



- in a section of a Team's and/or Driver's website dedicated to the Team's and/or Driver's sponsors and partners.

4.2 Use of Team Images

1. By Teams and drivers

Teams and Drivers may only use still images of the Team (i.e., images of the Car, Team support vehicles, Team and Drivers' equipment) but not any other Ferrari and/or Ferrari Challenge image. Said still images of the Team may be used exclusively for promotional activities or campaigns or communications activities relating to the Team. Written permission from Ferrari must, however, be obtained prior to any use of these images of the Team by the Team and/or by the Driver.

2. By Teams' and Drivers' sponsors/partners

The Teams' and Drivers' sponsors and partners may use still images of the Team (i.e. images of the Car, the Team support vehicles, the Team and Drivers' equipment) where the logo of said sponsor or partner appears on the aforementioned and to the exclusion of any other Ferrari and/or Ferrari Challenge image, exclusively for promotional activities and campaigns relating to the logo of the sponsor and partners of the Teams and Drivers in compliance with the directives and/or instructions of the "Teams' Guidelines" (i.e. the use of said images is not permitted for promotional activities or campaigns relating to products and/or services provided by the Team and Drivers' sponsors and partners).

Team and Drivers may use the aforementioned images of the Team only in the course of the year in which those images were made.

Before using any images of the Team, Team or Driver sponsors and partners must ensure that they first receive written authorization from Ferrari.

4.3 With the exception of the rights outlined in the present Article 4, the Teams, Drivers, their sponsors and/or partners are not authorized to use:

1. images, drawings, or other representations (still or moving) of Ferrari, the Ferrari Challenge, the Challenge events, or of Ferrari, Ferrari Challenge, and/or Challenge event vehicles, equipment, structures, circuits, staff, consultants, and/or managers (collectively "Ferrari Elements");
2. the name, logo, trademarks, identifications, designations, or any other elements owned by or pertaining to Ferrari, or directly or

indirectly referring to or referable to Ferrari Elements, including (but not exclusively) predominantly red elements or components (collectively "Intellectual Property");

3. objects (including merchandising products and/or promotional products/materials) containing and/or depicting Ferrari Elements and/or Intellectual Property.

4.4 Failure to comply with even one of the provisions contained in Article 4 may be punishable by the Challenge Committee with penalties that can include exclusion from the rankings and/or the suspension of the Driver's and/or Team's competitive activities within the Ferrari Challenge (Europe and/or North America and/or United Kingdom and/or Middle East and/or Australasia and/or Asia Pacific and/or Japan).

4.5 All approval requests must be made in compliance with the terms of Article 4 and submitted by email to (manuel.marchi@ferrari.com).

4.6 No commercial or charitable solicitation is permitted by Drivers, Teams, Driver Coaches, or others at any time.

5 Drivers' requirements

5.1 All Drivers, Crew Members, and Driver Coaches participating in the Ferrari Challenge must hold a current IMSA License and a physical (hard) card credential. Only IMSA-licensed individuals recognized as event participants will be permitted access to the "hot" pit lane and any other areas identified as "hot" during any Ferrari Challenge on-track sessions. Non-U.S. Drivers holding only a Fédération Internationale de l'Automobile (FIA) License must apply for an IMSA License to compete in Ferrari Challenge events, which are not listed on the FIA Calendar.

5.2 All Ferrari Challenge Teams must appoint a representative of the Authorized Ferrari Dealer (the "Entrant"), who must hold a current IMSA Entrant License to represent his or her team. The Entrant must also complete the Official Entrant Form and pay for applicable team licenses for Ferrari Challenge North America in advance of the Team's first race. The Entrant is required to attend all Ferrari Challenge races. In the event the Entrant cannot attend, a delegate must be appointed in writing to IMSA in advance of the event by completing an IMSA Entrant Delegate Appointment Form.



5.3 All Ferrari Challenge Teams operating a vehicle for an Authorized Ferrari Dealer and Ferrari Challenge Driver must be granted an Official Team License by Ferrari North America. All persons attending a Ferrari Challenge North America race in any capacity are subject to the approval of Ferrari North America Motorsports Officials.

6 Admission of drivers

6.1 A special committee appointed by Ferrari ("the Challenge Committee") will evaluate each individual entry application for the Ferrari Challenge. Drivers who have applied for entry and are deemed unsuitable by the Challenge Committee will be denied entry to the Ferrari Challenge. The Challenge Committee's decision in this regard is final.

6.2 Generally speaking, Ferrari reserves the right to reject applications for entry to the Ferrari Challenge or for individual Ferrari Challenge events. The Driver will be notified of a refusal and the reasons for such with reasonable notice.

6.3 Any registered Driver with an IMSA License is eligible for points.

6.4 Ferrari reserves the right to admit appointed Drivers of their choice to participate in a single round or the entire season. Drivers are subject to the normal registration requirements and procedures but will remain transparent for the final race standings.

6.5 Round 7 of the 2026 Ferrari Challenge NA Championship will be raced at Barcelona in Spain. From a sporting perspective, Round 7 race(s) will be conducted under this North American point system, but managed by Italian Sporting Authority. From a technical perspective, cars will be inspected by the Ferrari Challenge EU technical team. Only participating drivers in Round 7 are eligible for two (2) complimentary hospitality and Gala Dinner passes/invitations in Barcelona.

6.6 Drivers must fully comply with all regulations of conduct described in the Ferrari Challenge Regulations as well as instructions issued by the Race Director and Ferrari Challenge Series Manager. All Entrants and Drivers must remain at disposal of the Race Director until the unofficial results have been announced.

6.A Driver Conduct

6.A.1 All Drivers participating in the Ferrari Challenge are expected to demonstrate the highest levels of sportsmanship at all times, showing respect for fellow Drivers, their Cars, and Officials. Drivers who fail to demonstrate this respect may be excluded from the Ferrari Challenge series at any time and with no right of appeal. The same applies to individuals who behave in such a way as to bring the good name of Ferrari and the Ferrari Challenge into disrepute.

6.A.2 The spirit and intent of sportsmanlike racing competition is to avoid touching or endangering the vehicles of fellow participants. The possibility of inadvertent contact is a reality of racing. If, however, in the judgment of IMSA Officials, a Driver is crowding, bumping, chopping, blocking, or pushing other participants in any deliberate manner, that Driver shall be subject to immediate action, including the penalties that are applicable to Ferrari Challenge competition, listed in the regulations.

6.A.3 Drivers are always responsible for being aware of faster cars and must yield to faster cars when being lapped by remaining consistent and staying on line. Drivers being lapped will observe the passing (blue) flag or subject themselves to penalties as per the regulations.

6.B Driver Coaches

1. Qualifications
 - a) Any Driver Coach ("Coach") retained for the Ferrari Challenge must be an experienced coach or driver with demonstrated credentials. Each Coach must be approved in advance by the Ferrari North America Head Driving Coach ("Head Coach") and by IMSA before any participation in the Ferrari Challenge. The Driver Coach Application Form can be requested from the Head Coach. The completed form must be returned to the Head Coach including a complete driver's résumé for review by email at least two (2) weeks prior to the start of the season or the event in which a Coach plans to participate. The Coach will be notified when the application has been approved. Approval is good only for the current season.
 - b) A Coach must hold a current IMSA Driver's License.
 - c) Every Coach is expected to fully understand the Ferrari Challenge Sporting Regulations, and to understand and



support the purpose and philosophy of the series. A Coach is expected to demonstrate respectful and courteous behavior at all times, and to work with Drivers to ensure their conformity with the regulations and purpose of the Ferrari Challenge. Coaches whose behavior does not conform to this standard will be warned, either verbally or in writing, by the Head Coach, Ferrari Challenge Series Manager, or the Race Director. Following such a warning, a Coach whose behavior continues to fail to conform is subject to having his or her approval revoked by Ferrari North America or IMSA.

- d) Coaches must attend every scheduled Driver's and Coaches' Meeting at each event, and are required to be present at the start of the meeting. Failure to attend a scheduled meeting at an event may result in the revocation of a coach's license. Coaches must maintain a valid FNA team license and IMSA driving license. Coaches must wear official Puma fire suit, shoes, and gloves, at all official Ferrari tests and events regardless of any personal endorsement deal.
- e) In the event a Coach cannot attend a particular event (for example, due to a conflict with a race in which the Coach is driving), a Driver may appoint a delegate for that event from a list maintained by Ferrari North America and IMSA for this purpose. Prospective Coaches may request inclusion on this list by downloading and completing the Driver Coach Application Form.

2. Participation

- a) All Coaches must register with the Head Coach at least two (2) weeks prior to a race and sign in with the Head Coach at each race. Coaches will receive credentials and identification (decal on helmet), which will permit them to be in a Ferrari Challenge car.
- b) Coaches will only be permitted in cars that have the appropriate roll cage, second seat, and restraints installed and are approved by Ferrari Technical Inspection. These cars may carry special identification or markings, or cars without this approval may be marked. These markings are made at Ferrari North America's sole discretion. These markings may not be tampered with under any circumstances; doing so may result in the Car, Driver, and Crew Chief being removed from the event.
- c) Coaches are only allowed to ride or drive a car during sessions

marked "test" on the Official Timetable. On a typical weekend, Coaches may not ride or drive on Friday through Sunday, or any days where the Official Challenge Weekend Schedule is being held.

- d) The Coach must wear all of the required driver safety equipment (see Article 6D), including the Puma overall, as well as the identifying Coach decal on their helmet, at all times. Failure to notify IMSA Officials in the pit lane, prior to leaving the pit lane, that a Coach is either driving or riding in a car will lead to a reduction in track time in future sessions for that car. Official times will not be recorded while a Coach is in the car. No Coach is authorized to drive a competitor's Ferrari Challenge car alone unless a plausible reason is given to the Race Director and FNA Technical Representative, who will then authorize such activity on a case-by-case scenario. The Race Director and FNA Technical Representative in such instance will authorize the number of laps a coach may drive.
- e) It is understood that any Coach assisting Drivers at a Ferrari Challenge race or at any practice respects Ferrari and wears the Puma overalls when driving the Ferrari Challenge car. Otherwise, official Team apparel that is either neutral or features a Ferrari logo is required. No logos of other car manufacturers and or sponsors may be visible at any time.
- f) No solicitation for other services, sponsorship, participation in other racing series, or the like is acceptable, and discovery of such will result in expulsion from the Ferrari Challenge series.

6.C Spare ("T") Cars

6.C.1 Each Driver will be permitted to bring additional spare cars to each event. Its use will be governed by the following requirements:

6.C.2 The spare car will be prepared in full accordance with Ferrari Challenge Regulations, and will be identified by the Driver's assigned number plus the letter "T" in the same size and style. For example, the spare car for a Driver who used the number "00" would be identified on the hood and doors as "00T".

6.C.3 It is the responsibility of each Driver to have Ferrari North America Technical Staff record the spare car's chassis number and complete a full technical inspection prior to the event.



6.C.4 The Driver may replace his primary race car with the spare car if the Driver has an accident or other issue which does not allow the primary race car to continue at the event. The determination as to whether the car can be repaired at the event will be the decision of the Ferrari Challenge Officials and cannot be appealed. Once a car is replaced with a spare, any previously replaced cars are prohibited from returning to the track for the rest of the event, unless explicitly authorized by IMSA and FNA officials on a case-by-case scenario.

6.C.5 When deciding to switch to a spare car, the "Vehicle Replacement Request" form must be completed and submitted to ALL recipients listed in the form and approved by IMSA and FNA Technical Staff before the car is approved to go on track (See Appendix for form). The form is required starting from all official practice through all qualifying and race days.

6.D Safety Equipment

6.D.1 Driver safety equipment

1. Each Driver must arrive with full racing attire at the first race he or she attends.
2. Drivers must wear full-coverage helmets of recognized high quality and which include a face shield. Drivers must use helmets that satisfy FIA standard 8860-2010, or 8860-2018. Modification (drilling of holes, etc.) is prohibited and shall void the homologation.
3. 8860-2004 helmets shall no longer be valid for use in IMSA after December 31, 2020. 8860-2010 and 8860-2018 helmets shall no longer be valid for use in IMSA after December 31 of the calendar year ten (10) years after the manufacture date shown on the FIA label in the helmet. Drivers must have the Eject Helmet Removal kit or the Stand 21 Lid Lifter Balaclava installed in their helmets.
4. Drivers must wear outermost a driver suit homologated to FIA 8856-2000, 8856-2018, or meeting the SFI 3.2A specification. Gloves, underwear, a balaclava, socks, and shoes homologated to FIA 8856-2000, 8856-2018, or meeting the SFI 3.3 specification are also required. While any manufacturer's items may fail inspection due to condition over time, FIA homologated items shall no longer be valid for use in IMSA after December 31 of the calendar year ten (10) years after the manufacture date shown on the FIA label; or after December 31 of the year of expiration shown on the FIA label. Driver suits homologated to FIA 8856-2000 are permitted during the IMSA 2020 season but are prohibited after December 31, 2020. Driver suits homologated to FIA 8856-2018 are mandatory from January 1, 2024.

5. Drivers must wear a Frontal Head Restraint (FHR) that is approved according to FIA standard 8858-2002, 8858-2010 or SFI 38.1. Drivers are strongly encouraged to use helmets with tether anchorages fitted by the manufacturer as original equipment. Homologated tethers, identified by a FIA 8858-2002 label, are required and must not be used beyond December 31 in their manufacturer's declared year of expiration. Evaporative-loss Freon® cool suits are prohibited.

6.D.1 All teams are required to install and supply a functioning MSE Driver Yellow Full Course Caution Light indicator wiring harness and signal box at the team's expense. Boxes and harnesses are available directly from the supplier, Creative Motorsport Solution (<https://www.gomuchfaster.com/collections/support-series>)

6.D.2 Refueling and over-the-wall safety equipment

1. At all times that cars are refueled in the pit lane and paddock/truck areas, the Refueler, the Vent Operator where permitted, and the Fire Bottle Operator must wear outermost a fire-resistant uniform that meets FIA 8856-2000 or SFI 3.2A/5 specification. In addition, fire-resistant long underwear, socks, gloves, balaclava, and shoes meeting SFI 3.3 or FIA 8856-2000 specifications must be used. Also required is a full-face helmet meeting Snell Memorial Foundation, SA/2020, SA 2025 FIA standard 8860-2010 - Advanced Helmet 8860-2018 Test specification, or SFI Foundation 31 specifications, with the face shield positioned down during the actual refueling. Refueling is not permitted in any garage, awning or permanent building. Failure to wear the required safety equipment while refueling, or refueling in restricted areas, may result in a fine, point deduction, expulsion from the series, or any other penalty deemed appropriate by FNA.
2. All Driver, Refueler, Vent Operator, and Fire Bottle Operator personal protective equipment is subject to inspection by IMSA and/or Ferrari Technical Staff at safety checks, scrutineering and/or technical inspection prior to first use in the season. IMSA and/or Ferrari Technical Staff may re-inspect any equipment at any time.
3. Crewmembers must wear clean uniforms and other appropriate and safe attire at all times in order to present the best possible appearance to the public. Tank tops, shorts, open-toed shoes, and similar attire are prohibited. Industry support representatives must be clearly identified as non-Team members. Participants in the pit area must be adequately attired in long pants, closed-toed shoes, and sleeved shirts during on-track activity. Inappropriate



attire is prohibited. Shorts, open-toed shoes, and sleeveless shirts are prohibited at all times over the pit wall.

7 Application form and entry fees

Ferrari Challenge North America requires completed registration and entry fee payment prior to a selected race. Information on entry fee packages may be requested from the Ferrari Challenge Series Manager. Entry fees are non-refundable and non-transferable to the next season

7.1 Drivers who are considered professional drivers, on the basis of experience or past history (in the sole judgment of the Challenge Committee), may not be permitted to race in the Ferrari Challenge. At each event, only one (1) Driver may be entered to compete under an individual Vehicle Identification Number (VIN) or, in the case of usage of a spare car, the VIN may be switched as per Ferrari Challenge Regulations.

7.2 Entries for the Ferrari Challenge must be submitted through the Authorized Ferrari Dealer for whom the Driver intends to race.

7.3 Each Team must be represented by an officially appointed Authorized Ferrari Dealer personnel (the "Entrant") in accordance to Article 5.2. The Entrant will have overall responsibility of the Team and is required to be present at all Drivers' Meetings and Crew Chiefs' Meetings. If the Entrant is not in attendance, the Challenge Committee reserves the right to penalize the Team. Furthermore, one (1) Electronic Engineer from the Team is required to attend each race.

7.4 If in the sole judgment of Ferrari North America and IMSA any Driver is determined to need additional driver training, any or all of the following may be required:

1. Use of a Ferrari North America and IMSA-approved Driver Coach during a prescribed probation period. Cost of the coach will be the sole responsibility of the Driver.
2. Participation in a Ferrari North America and IMSA-approved driving school. The cost of this school will be the sole responsibility of the Driver.

7.5 Drivers who have not previously competed in Ferrari Challenge North America must submit an application to the Ferrari Challenge Series Manager that completely details their previous racing experience. Novice

Drivers must also register with an official Ferrari North America and IMSA-approved Driver Coach for the season. A list of available Coaches can be requested from the Ferrari North America Head Driving Coach. Decisions regarding the eligibility of Drivers will be made by the Challenge Committee, whose decisions are motivated by safety and the spirit of the Ferrari Challenge series, and whose decisions are final. Entry forms for the Ferrari Challenge, information on series registration fees, and schedules not included in these regulations will be available from the Ferrari Challenge Series Manager at Ferrari North America.

7.6 Race numbers will be assigned to the Cars per the following table:

- Trofeo Pirelli / Trofeo Pirelli-AM 1-99
- Coppa Shell / Coppa Shell-AM 100-199

Numbers will be assigned by Ferrari North America. Requested numbers will be assigned if available on a first-received, first-assigned basis. Assignments will be valid for the 2026 season. The Ferrari Challenge Champions (1st, 2nd, and 3rd place overall) from the previous season in each class shall be entitled to use the number "1", "2" and "3" respectively if he or she so chooses.

7.7 Calendar and Entry Fees

Round 1: Thermal	(March 11 - 15)
Round 2: Sebring	(April 8 - 12)
Round 3: COTA	(May 13 - 17)
Round 4: Laguna Seca	(June 17 - 21)
Round 5: Sonoma	(July 22 - 26)
Round 6: Road America	(September 9 - 13)
Round 7: Finali Mondiali - Barcelona	(November 18 - 22)

\$ 116,000 Full-Season 296 Challenge Entry

8 Insurance

8.1 In the event of an on-track incident requiring medical assistance or a physician's assessment, regardless of severity, a medical hold will be placed on the involved driver at the discretion of IMSA officials. Medical hold drivers will be required to have IMSA's Return to Racing form completed and signed by a qualified assessing physician prior to the hold being removed. It is the sole responsibility of the medical hold driver to submit the completed form to an IMSA official to be reviewed by IMSA



Medical prior to returning to on track competition. Failure to do so may result in fines and/or penalties. Drivers will still need approval from IMSA to return to racing regardless of medical staff onsite.

8.2 The Challenge Committee strongly recommends that each participant (Drivers, Crew, and Officials) in the Ferrari Challenge consider the purchase of appropriate insurance to cover situations that may arise in racing. In addition to personal and medical coverage, Drivers should consider the purchase of On-track Collision Damage Insurance to cover the Ferrari Challenge cars during competitive portions of the events. Drivers are encouraged to consider the financial implications of such coverage, and the Challenge Committee strongly recommends such coverage to all Drivers, although it is not in a position to recommend any company, broker, or agent offering such coverage.

9 Race length

The Ferrari Challenge races will be held according to the official season calendar: Each Ferrari Challenge race weekend will host two official races for each category. These races will be thirty (30) minutes in duration. The 2026 Ferrari Challenge schedule is subject to change dates and/or venues for all rounds in a best effort to complete a 2026 Championship.

10 Official schedule and supplementary race regulations

10.1 Ferrari will send an Official Schedule for each event. This schedule will include the times for Drivers' Meetings, practice, qualifying, and racing. It is the competitor's responsibility to be prepared to participate in the correct session at the time specified on the Official Schedule.

10.A Official On-Board Camera

10.A.1 Ferrari North America requires the installation of a specific video camera system in every Ferrari Challenge car participating in the event. This system will be provided by, and the installation will be directed by, Ferrari North America and IMSA. The location and operation of this camera will be mandated by IMSA, and is to be used exclusively by IMSA Officials. The camera and storage media may not be viewed, adjusted, erased, downloaded, handled, or controlled by anyone except at the

specific direction of an IMSA Official. The system, images, and content of the device is the property of the Ferrari Challenge series and will be used as needed to review on-track activity. It is not available to the Teams at any time or for any reason.

10.A.2 Additional on-board camera systems are permitted if affixed on the interior of the Ferrari Challenge car. No exterior mounted cameras will be permitted unless approved in advance by the Ferrari North America Communications Department.

10.B Timing And Scoring

10.B.1 IMSA will appoint an Official Scorer, who is responsible for timing and scoring the event. Results posted by the Official Scorer are provisional until approved by the Race Director. A competitor may request that the Race Director have the timing, scoring, and results rechecked by the Official Scorer. Such actions, decisions, rulings, and/or penalties made or taken with respect to such matters are conclusive.

10.B.2 Each primary and each spare ("T") car shall be fitted with an approved timing and scoring transponder to be mounted on the area of the car mandated by Ferrari North America. The transponder must be powered and functional at all times the car is on the racetrack or in the pit lane. During Practice and Qualifying sessions, a car on track without a functioning transponder is required to immediately pit to repair the transponder. It is the responsibility of each team to provide the transponder for each car they enter in the event.

11 Sporting and technical scrutineering

11.1 Pre-race technical and safety scrutineering ("Technical Scrutineering") will take place as per the Official Schedule decided upon by the Challenge Committee and in compliance with the specific articles of the codes and regulations outlined in Article 1.4.

11.2 The Ferrari North America waiver is required to be executed fully before going on track. Any person on track at a Ferrari Challenge Series event who has not completed this waiver is out of regulation and considered trespassing. The waiver can be requested at track or in advance from Ferrari Support (Support@FerrariSupport.com).



11.3 At the first event, for each Driver, a driver weight will be taken to establish the baseline for minimum car weight that includes the Driver. This weigh-in will be completed during the sporting checks on the first race for each Driver.

11.4 Ferrari Challenge cars must be presented at the Technical Scrutineering at the beginning of each race event in accordance to the Official Schedule. Cars must be properly prepared and race ready, must display all sponsor decals properly attached, and must not show any significant body damage. Cars that do not comply may be rejected by the Technical Inspection Team and the associated inspection sticker will not be provided; thus, the car will be excluded from participation until properly prepared.

11.5 It is mandatory to present the Drivers' race apparel (suit including fire-resistant undergarments and Driver's helmet with HANS device) at the Technical Scrutineering with approved safety inspection decals in accordance with Article 6.D.1.

11.6 All technical updates/campaigns published and released by Ferrari must be completed before the event. In cases where the updates are done at the track, all updates must be done before the car returns to the track unless approved by a Ferrari Challenge Official. Any vehicle on track without the proper updates performed on the car will be subject to penalties.

11.7 The inspection of all the Drivers' sporting documents will be carried out in each Ferrari Challenge participation round. Drivers must ensure that their sporting documents are ready for inspection at any time.

12 Drivers' meetings

12.1 Drivers' Meetings will be held at the time and place specified in the Official Schedule. Official information will be provided to all Drivers, either verbally or in writing, at official Drivers' Meetings.

12.2 All Drivers entered in the Ferrari Challenge event, the Entrant for each team, and Coaches are required to attend all Drivers' Meetings. Any Driver who does not attend a Drivers' Meeting, as proven by the Driver's signature on an official sign-in sheet, may be penalized by the Challenge

Committee. The first non-excused offense could result in a loss of practice or qualifying time. Subsequent offenses during the same event will result in greater penalties that could include an IMSA fine up to \$ 1,000.

12.3 The Entrant for each team is responsible for acquiring all official posted communications, for informing all Team members of such communications, and for ensuring that any actions required by the communication are taken by the Team. This includes all communications sent to the Teams throughout the season. It remains the Entrant's responsibility to ensure that all members of his or her Team, including Drivers and Coaches, receive such communications and acknowledge the same.

12.4 Each Team must be represented by an officially appointed Authorized Ferrari Dealer Entrant at the Drivers' Meeting as well as at the Crew Chief Meeting.

13 Tires and fuel

13.1 Ferrari will provide each successfully scrutineered and participating car on the entry list with a set of:

- eight (8) Pirelli slick tires: four (4) front and four (4) rear as indicated in the Ferrari Challenge Technical Regulations; and/or
- if required, four (4) Pirelli rain tires in case of wet conditions (as declared by the Race Director): two (2) front and two (2) rear.

Each tire will be identified by an identification code imprinted by the manufacturer and may be subject to audit by the scrutineers at any time of the event. The slick tires may not be modified in any way and must be used ONLY in Qualifying 1, Qualifying 2, Race 1, and Race 2.

A Team may request the replacement of one or more tires on its cars. The "Tire Replacement Request" form must be completed, submitted to ALL recipients listed in the form and approved by IMSA and technical before the tire is approved for use (see Appendix for form). The form is required for all qualifying and race sessions.

Each competitor is allowed to use no more than two (2) "Joker" tires during the season, only under the following conditions:

- Definition of "Joker" tire: a Joker tire (slick\rain) is an extra tire additional to a competitor's permitted number of tires.



- The use of a "Joker" tires must be authorized by the Ferrari Challenge technical delegate and IMSA.
- The "Joker" tires are marked by Pirelli in a specific way.
- The "Joker" tires may only be used in the event in which it was punched.
- The cost of the "Joker" tires will be invoiced directly to the Competitor by Pirelli.
- The substitution of the two (2) allowed joker tires will not result in a grid penalty.

For the substitution of NON "Joker" tires, if you receive 1 (one) tire, 3 (three) positions grid penalty on the starting grid for the earliest race during the same event.

For the substitution of 2 (two) or more NON "Joker" tires, 5 additional grid spot penalty will be applied. In the event that the tire is replaced, not in the presence of a structural defect (defined by Pirelli), the car in question will be penalized five (5) positions in the starting grid of the next race.

13.2 Ferrari Challenge and IMSA Officials with the consent of Pirelli may increase the number of tires supplied to each Driver by an equal number if conditions make this necessary for safety reasons.

13.3 The use of tire warmers or any other means of artificially varying the temperature of a tire is prohibited, as is any modification of the tire compound by chemical modification, or any similar method.

13.4 All Drivers must use the same tire type (i.e., slick or rain) in all races and qualifying sessions. The Race Director shall determine the required tire type prior to the start of the race or qualifying session. Should conditions change during the race or qualifying session, the Race Director will order the cars into the pits and all competitors will be required to change to the appropriate tire. Tire selection for the practice session is open.

13.5 Teams must provide to Pirelli three (3) sets of wheels for each car entered in the race. The tires provided by Pirelli as per Article 13.1 must be returned to Pirelli no later than ninety (90) minutes after the final race of the weekend; the wheels on which these tires are mounted must be cleaned prior to delivery to Pirelli.

13.6 A specific 98 octane (or higher) fuel will be made available at all Ferrari Challenge events and must be used for all sessions. This or other supplied fuel must be used exactly as supplied without additives

or modifications. Violation may result in an IMSA fine of \$ 25,000 to the Licensed Team Manager.

13.7 Ferrari North America may supply a special valve and coupling for the purpose of fuel sampling, which must be fitted if supplied. Fuel may be tested at any time during an event. Ferrari North America may arrange to take a fuel sample from a car and have the sample sent to an independent laboratory for testing.

14 General safety and pit regulations - paddock assignments

14.1 Each Team will be provided with a clearly defined area in the paddock by Ferrari Challenge Officials and/or the event organizers. This space will contain the facilities of the individual teams, Ferrari Challenge cars, and support equipment. These spaces will be assigned by Ferrari Challenge Officials. Each Driver will be responsible for keeping his or her own space in order, and for the behavior of any person directly or indirectly connected with the Driver's participation in the Ferrari Challenge.

14.2 A complete list of equipment with measurements must be supplied to Ferrari North America's Paddock Management Firm as requested.

14.3 All Team trucks and support vehicles must be maintained in clean and appropriate condition at all times and must display the series logos as required in the Ferrari Challenge Regulations. All Team trucks and support vehicles must furthermore display the name and logo of the relevant Authorized Ferrari Dealer exclusively. No other Team names are permitted to be displayed on the Team's equipment.

Team vehicles of any type that do not meet this requirement, in the sole opinion of the Ferrari Challenge Series Manager, may be excluded from the paddock. It is recommended that each Team have their trailer designs pre-approved by the Ferrari Challenge Series Manager in advance of the first race.

14.4 The 296 Challenge cars and/or any equipment, tents, signs, or other items may not be used as billboards to communicate slanderous or disrespectful remarks about other Drivers, Crew Members, or Officials. Ferrari North America reserves the right to remove such vehicles, items, or the entire Team from the event.



14.5 There will be a Pit Speed Limit of 60 km/h in effect at all times during an event. The Pit Speed Limit will be in effect between a marked In Line (normally with a pylon) and a marked Out Line (normally with a pylon). Speed limit will be 60 km/h, which is the speed of the speed limiter equipped on the 296 Challenge.

14.6 Each Team will be responsible for keeping his or her own pit area in order. Private hospitality is strictly forbidden in the pit area or paddock without the prior consent of the Ferrari Challenge Series Manager. Only minimal snacks and drinks for the Crew are permitted in this area. Independent track suite rentals, hospitality area, or at-track activations are prohibited.

14.7 Any person admitted to the hot pit area must have the appropriate credential, which must always be clearly visible. It is mandatory for all Crew to apply for a current IMSA License. Single-event, non-transferable licenses may be purchased through IMSA prior to each event. It is the responsibility of the Entrant to ensure that all Crew are properly credentialed.

14.8 Only staff with a valid series credential will be permitted in the pit lane (at circuits where this is permitted) during the event, and only two people for each Ferrari Challenge car will be permitted access to the outer pit wall during the time the car is on track, and only if conditions permit in the sole opinion of the Race Director. Any person admitted to the pit lane must hold a valid IMSA License.

14.9 Support personnel (mechanics, technicians, and similar) must be dressed in a rational and safe manner. All Team uniforms must carry the official Ferrari Challenge logo and the name of the relevant Authorized Ferrari Dealer.

14.10 All portable equipment must remain inside the pit area assigned to each Team, or must be returned to that area after the car has been serviced and has left the pit area.

14.11 When fueling in the paddock area, proper protective clothing must be worn and there must be a manned fire extinguisher present in accordance to Article 6.D. It is strictly forbidden to refuel cars under Team awnings. When garage buildings are used, it is strictly forbidden to refuel or run engines inside the building. Failure to follow these procedures may result in loss of track time or other serious penalties as determined by the Challenge Committee.

14.12 There will be no dismantling or teardown of any paddock equipment, including but not limited to tents, awnings, trailers, and loading of cars prior to the end of Race 2 podium on each event day. It is the responsibility of the Entrant and Team Manager to comply with all teardown procedures listed. Failure to comply could result in penalties or fines as determined by FNA.

15 Signals and radio frequencies

15.1 Only the UHF (450-470 MHz) frequency band is permitted for pit-to-car radio communication.

Competitor radio traffic is limited to a maximum of four (4) watts on handheld radios and a maximum of ten (10) watts ERP on mobile units (base stations) and/or repeaters, and must not transmit to car on one frequency and receive on another at greater than 5 Mhz spacing. All car communication must operate on 12.5 KHz channel spacing. Digital and/or encrypted or any radio transmission scheme between Team and Driver not understandable using a standard scanner at any time during any qualifying session or race is prohibited.

15.2 Each car participating in the Ferrari Challenge must be equipped with radio communications equipment permitting the Driver and Team to be in contact at all times when the car is on track.

It is the Team's responsibility to monitor the Race Control radio frequency, and to immediately advise their Driver(s) of any instructions from the Race Director or other official. Any time a car is on track, a Team member who is in radio communication with the Drivers must be located in the Team's pit box. A Team's or Driver's failure to monitor radio instructions from Race Control may not be a basis for any objection or protest. This regulation in no way replaces or overrides the requirement that every Driver obey all flag signals.

16 Private practice / Test Sessions

Teams are required to seek permission from Ferrari North America (manuel.marchi@ferrari.com) if considering a test within twenty-one (21) days prior of the start of an official Challenge race week.



17 Official practice and qualifying

17.1 In the event qualifying must be cancelled, the starting order shall be set on points. In round 1 race 1, starting order shall be set on lap times from practice 3.

17.2 Two (2) official qualifying sessions will be scheduled at each event to set the grid for each race.

Official qualifying will take place on the days and times described in the Official Schedule.

17.3 Official qualifying will take place in both dry and wet track conditions unless deemed unsafe by the Race Director. Dry or wet qualifying will be determined by the Race Director prior to each qualifying session. In the event that track conditions change during a qualifying session, the Race Director will instruct all Teams and Drivers how to proceed in that session.

17.4 In cases in which the number of cars entered exceeds the circuit capacity, the Ferrari Challenge Series Manager and IMSA Officials may split cars into two groups for the session in a manner designated by IMSA for the session. This will be done by drawing lots, and each group must not exceed the maximum circuit capacity.

17.5 If a car halts along the track during a qualifying session, it may only restart when the Track Marshall deems it safe to do so. If the car requires mechanical help or assistance, it must return to the pits to be checked by a Ferrari Technical Staff and, if authorized, may re-enter the session.

17.6 Cars may under no circumstances enter the paddock while official qualifying is underway. Any work required on the car may only be carried out in the pit lane, specifically in the spaces in front of the pits assigned to the Driver.

Race Officials may alter the decision on sessions at any time should weather circumstances or force majeure require such action.

17.7 During qualifying and races, any work on a car must be performed exclusively in the pit lane, specifically within the designated space in front of that car's assigned pit. All work must cease immediately once the checkered flag is displayed to end the session. Cars in pit lane are prohibited from returning to the paddock/garage area until all cars are released to parc fermé at the conclusion of the session. However, a

damaged car may be released from pit lane before the end of a session if authorized by an IMSA pit lane official. The damaged car remains under parc fermé rules unless released early from FNA Technical personnel.

1. A Driver should achieve a qualifying time not exceeding 120% of the fastest Driver in their class during the qualifying Session. Drivers not achieving 120% may be permitted to compete in a Race at the sole discretion of the Race Director.
2. Causing a Red Flag.
 - a) Practice
 - Any Driver that causes a Red Flag during an Official Practice session may lose its fastest timed lap in Qualifying.
 - b) Qualifying
 - Any Driver involved in an incident that initiates a red flag stoppage during a Qualifying session may be penalized by deletion of their two (2) fastest timed laps of that Session and may be prohibited from further participation. Any Driver involved in an incident or concurrent incident resulting in abandonment of qualifying may be placed at the back of the starting grid for the Race.
3. If the Car does not participate in qualifying, or multiple Cars do not participate in qualifying, they are ordered at the back of the grid in class Driver championship points order.
4. Every reasonable effort is made to provide a minimum cumulative green flag running time for the Qualifying Sessions. In any circumstance, should acceptable qualifying time not be met as determined by FNA and the Race Director during the Session, the grid order is established by "other means" for Race #1 of the event. Other Means To Set The Grid. Should qualifying be abandoned or "other means" be required to set the grid, the Cars shall be gridded using the class Driver championship points standings. The Cars are ordered by the following priority:
 - a) The Car with the most Driver championship points in the class for the current season shall be gridded first, with other Cars following in descending order. Tiebreaker then by b)
 - b) Should a Car not have Driver championship points in the class for the current season, the Car shall be gridded by the Car with the most Driver championship points in the class from the previous season. Already tie-broken, then c)
 - c) Should a Car not have Driver championship points in the class for the current or previous season, the Car shall be gridded by the Car with the most Driver championship points earned in any class from the previous season. Tiebreaker by class order, then d)



- d) Should any one or all of these individual circumstances not be applicable to a particular Car(s), the Car(s) are placed on the grid at the Race Director's discretion.

18 Admission to the start, pre-grid, and starting grid

18.1 The starting grid for the race will be based on times from the official qualifying session, gridding by class and ordered by fastest official qualifying time. If the official qualifying session is abandoned, the starting grid will be gridded by "other means" as 17.7.4.

18.2 A Driver or Team may request the Race Director to admit a car that has not completed any practice laps to the first race, provided this does not eliminate another car that has already qualified. Any car thus admitted will start from the last place on the starting grid. A Driver or Team may ask the Race Director to admit a car to the second race that has not started in the first race. Any car thus admitted to the start of the second race will occupy the last place on the grid.

18.3 Cars must be lined up thirty (30) minutes prior to the start of the race in the pre-grid area.

19 Race

19.1 Race Start

The race will start at the time indicated in the Official Schedule. The procedure during the period immediately prior to the start is as follows:

1. At a time determined by the Race Officials, before the scheduled start time, the cars will leave the pit area to do laps of the circuit and may pass through the pit lane or proceed to their grid position on the grid. These are the reconnaissance laps. All cars must complete at least one reconnaissance lap in order to go to their grid position.
2. Three (3) minutes before the start, everyone except Drivers and Race Officials must leave the track.
3. One (1) minute before the start, engines are started.
4. Thirty (30) seconds before the start, the IMSA Grid Official will signal that the cars must proceed and start a full lap of the circuit, keeping their respective positions in the formation; the Driver in pole position must adapt his or her speed to that of the Pace Car,

- keeping a distance of no more than twenty (20) meters. Passing of other cars is not permitted during this lap.
5. Any Driver who cannot start his or her car must immediately indicate this to the IMSA Grid Official through radio or by raising an arm. The Driver's mechanics must then push the car back to the pits under the supervision of the IMSA Race Officials.
 6. If during this time the car starts, the Driver may restart the formation lap and, upon catching up with the main group, must remain in the back of their class without overtaking any other car.
 7. If a Driver has difficulty in leaving his or her position on the start grid when the IMSA Grid Official marks the start of the formation lap, he or she may return to the pre-start position on the grid before the start of the race if he or she has not been passed by all the other cars that have started on the formation lap. If the car fails to start and the mechanics and/or officials cannot push it, an assistance vehicle will have to come out and bring it back to the pits. In such cases, once the car is repaired, it may restart from the pit lane after the race has begun.
 8. During the formation lap, all Drivers must maintain their grid positions and keep the prescribed distance between their car and the one in front. The Race Director will issue precise instruction in this regard at the Drivers' Meeting. Cars must not overtake the Safety Car until it has exited the racetrack. After the Safety Car has exited the racetrack, Drivers must maintain their pace and positions as on the formation lap or as instructed, and must remain in formation until the display of the green flag by the Starter. The pole sitter in each category has earned the right to start the race and to cross the starting line even or ahead of the other cars. Cars must maintain the speed of the Safety Car or as instructed until the pole sitter reaches the Start Zone. The Start Zone is indicated by cones, stripes, and/or as instructed by the Race Director. The car in the second starting position must maintain position alongside the pole sitter until accelerating when the pole sitter accelerates. The pole sitter may accelerate upon reaching the Start Zone and the green flag shall be displayed while the pole sitter is within the Start Zone. Cars must remain in line in their respective grid line (in-line means overlapped and behind the car they are following on the grid) and must not overtake within their starting column until they individually cross the starting line after display of the green flag.
 9. If a false start occurs due to a Driver deviating from instructions given at the Drivers' Meeting, the Race Start regulations, and/or



the position assigned before the starting (or restart) signal is given, the Race Director may assess a penalty. Gamesmanship, brake checking, or manipulation of the pace or procedure is prohibited. A missed shift, wheel spin, or another unavoidable situation on the start may be determined by the Race Director and is conclusive.

The standard start procedure described above may be modified by the Challenge Committee for organizational reasons.

19.2 Pit stop

The car's engine must be immediately turned off during any pit stop made for any reason. If the car does not come to a halt in its allotted area in the pit lane, it may only be pushed by hand by the Team Mechanics to that area. Once the pit stop is completed, Drivers must restart the car themselves using the ignition; however, an external power source may be temporarily attached to the car if any problem should arise.

19.3 End of the race

Once the duration of the race expires, the pit exit is closed and the checkered flag is displayed to the leading car as it crosses the finish line on the racetrack. Cars are ordered in the results according to the number of whole laps completed during the race subject to any penalties applied. For cars completing the same number of laps, the time when the cars cross the finish line determines the order.

20 Safety car

20.1 The Safety Car is identified as such and fitted with an augmented flashing light system and may be dispatched to neutralize the race at the discretion of the Race Director.

20.2 The primary purpose of the Safety Car is to create a traffic interval on the racetrack so that responders may handle situations more safely and quickly; therefore, it is essential that all cars catch up with the field as quickly as possible consistent with safety.

20.3 Special Safety Car procedures may be discussed at a Team Manager and/or Drivers' Meeting and/or communicated to Drivers by Race Control.

20.4 The Safety Car may be dispatched at any time during a race in order to correct a hazardous situation. Drivers will be warned by the In-

Car Safety Light System dash lights. In this case, overtaking is prohibited anywhere on the racetrack. When possible, the Safety Car (with its lights on) enters the racetrack ahead of the overall leader, who must slow to the Safety Car's speed to facilitate this or may be subject to penalty. All Drivers must then follow the Safety Car in single file. A Driver must not overtake the Safety Car unless specifically instructed to do so by the Race Director.

20.5 This procedure may be modified at the Race Director's discretion, including not picking up the overall race leader at the start of the intervention, if immediate dispatching is deemed critical.

20.6 If the Safety Car is required to pick up a car that is not the overall leader, when deemed appropriate, the Race Director will instruct an initial wave-by of all cars between the Safety Car and the overall leader. Such cars must overtake the Safety Car on the right, remaining in order in single file, then proceed around the racetrack as quickly as possible consistent with safety to rejoin the field at the rear of the car(s) remaining behind the Safety Car. Overtaking the Safety Car must be done only on the right, unless otherwise instructed by Race Control.

20.7 The Safety Car may be used to lead formation lap(s) prior to the start of a race.

20.8 Following a Safety Car period during a race on the final lap of Full Course Yellow, the Safety Car will extinguish its roof safety lights and leave the field under the control of the race leader. The race leader must maintain the pace of the Safety Car until such time as the Driver reaches Start Zone (see Article 19.1.8), where he or she may accelerate toward the display of the green flag. On a restart, racing and initiation of overtaking may occur at the display of the green flag.

21 Parc fermé

21.1 At the conclusion of the qualifying sessions and races, all Drivers must drive their cars directly to the Parc Fermé without stopping for any other purpose, except for the first three finishers in each class, who may be directed to remain at the podium for a short time for trophy presentation. Those cars will then be driven directly to the Parc Fermé. Any cars that are late in reaching the Parc Fermé will be classified as non-finishers in that sessions results. Cars must remain in the Parc Fermé until officially released by Ferrari North America Technical Staff. Cars may be retained beyond the normal time for possible inspections. The Parc Fermé



is closed for the duration of the inspection, and Crew, Drivers or otherwise unrelated individuals are prohibited from entering the area. Teams must remain available for the duration of the Parc Fermé and may not leave the premises.

Note that depending on the venue, the Parc Fermé might be distributed over more than one location. All above regulations apply to each location.

21.2 For all official Ferrari Challenge practice, qualifying, and race session, it is strictly prohibited to reset or delete any telemetry data from the vehicle's data acquisition system. During the qualifying and race session it is strictly prohibited to switch off the battery switch and/or master switch until the vehicles has been official released from Parc Fermé.

21.3 Cars may be weighed in the Parc Fermé at the Organizers' sole discretion. Weighing will be in accordance with the Ferrari Challenge Technical Regulations.

21.4 Ferrari North America may confiscate and/or impound any 296 car, recording or video device, or any other piece of team or dealer equipment for any reason, at any time.

21.5 At no time during the entire event are teams allowed to use such any technical scrutineering equipment without having an FNA representative to oversee the checks or operations. Team representative must be present at Impound to be informed of any decisions taken regarding possible technical checks. Team representatives are prohibited to enter Impound unless instructed by a FNA Official, and Drivers must depart directly after delivering the Car. Team equipment is prohibited in Impound unless otherwise instructed by a FNA Official. Computers and/or electronic equipment are prohibited in Impound unless otherwise instructed by a FNA Official. Failure to follow this rule will result in penalties.

22 Podium

22.1 Drivers of each class who finish in the first three positions in each race at each event in each of the racing categories will receive trophies. Drivers must make their own way to the podium without delay to take part in the prize-giving ceremony, for which they must wear the official race

overalls, official race shoes, and the tire supplier hat (to be provided on site). Drivers must at all times behave in a manner worthy of the prestige enjoyed by Ferrari and the Ferrari Challenge. Drivers who are late to podium and delay the ceremonies for other competitors are subject to a loss of championship points.

22.2 The Organizers may present additional trophies and awards at their sole discretion. These awards may or may not be announced in advance.

22.3 The Drivers must make themselves available to authorized photographers, journalists, and TV camera operators before and after the ceremony.

22.4 The prize-giving procedure is of primary importance to any Ferrari Challenge event. The Organizers must ensure that the preparation, staging, and organizational protocols are up to the standards of the Ferrari Challenge. The prize-giving ceremony will begin at the time indicated on the Official Schedule. Drivers who are unjustifiably absent, who delay the prize-giving ceremony, or fail to comply with the instructions contained in Article 22 may be fined or penalized by IMSA Officials.

At the end of the races, the following will be presented with prizes:

- the first three ranked Drivers in the Trofeo Pirelli class;
- a representative of the Dealer of the winner of Pirelli class;
- the first three ranked Drivers in the Trofeo Pirelli-AM class;
- a representative of the Dealer of the winner of Pirelli-AM class;
- the first three classified Drivers in the Coppa Shell class;
- a representative of the Dealer of the winner of the Coppa Shell class;
- the first three classified Drivers in the Coppa Shell-AM class;
- representative of the Dealer of the winner of the Coppa Shell-AM class;
- the first ranked Shell Driver of the Ladies' Cup;
- the first ranked Shell- AM Driver of the Ladies' Cup;
- the first Shell ranked Driver of the Gentlemen's Cup;
- the first ranked Shell-AM Driver of the Gentlemen's Cup.



23 Standings and points

23.1 After each race, the following general standings will be drawn:

- Ferrari Challenge Trofeo Pirelli
- Ferrari Challenge Trofeo Pirelli-AM
- Ferrari Challenge Coppa Shell
- Ferrari Challenge Coppa Shell-AM
- Ferrari Challenge Shell Ladies' Cup
- Ferrari Challenge Shell-AM Ladies Cup
- Ferrari Challenge Shell Gentlemen's Cup
- Ferrari Challenge Shell-AM Gentlemen's Cup
- Overall Dealer Cup

In order to score any points, a Driver must be officially classified as having entered in each event.

23.2 Points will be awarded on the basis of the finishing order, according to the following table, for each class in each race completed on any race event weekend.

1 - 35	11 - 20	21 - 10
2 - 32	12 - 19	22 - 9
3 - 30	13 - 18	23 - 8
4 - 28	14 - 17	24 - 7
5 - 26	15 - 16	25 - 6
6 - 25	16 - 15	26 - 5
7 - 24	17 - 14	27 - 4
8 - 23	18 - 13	28 - 3
9 - 22	19 - 12	29 - 2
10 - 21	20 - 11	30 - 1

- +1 fastest lap (per class/per race);
- +1 pole position (per class/per race).

The pole position point will be given to the Driver who sets the fastest time in qualifying for that class.

23.3 Dealer Cup standings will be calculated
Dealer Cup standings will be calculated based on the total number of championship points earned by each Dealer during the 296 Challenge season. The Dealer Cup points position awarded includes all points awarded by all cars in each class in each race per Team. After Round 7, the Dealer with the most cumulative overall points between all classes will win the overall Dealer Cup. Points are awarded per Article 23.2.

24 Titles

24.1 The following titles will be awarded at the end of the season:

- FERRARI CHALLENGE TROFEO PIRELLI CHAMPION
This will be awarded to the Driver ranked number one (1) in the overall Trofeo Pirelli standings.
- FERRARI CHALLENGE TROFEO PIRELLI-AM CHAMPION
This will be awarded to the Driver ranked number one (1) in the overall Trofeo Pirelli AM standings.
- FERRARI CHALLENGE COPPA SHELL CHAMPION
This will be awarded to the Driver ranked number one (1) in the overall Coppa Shell standings.
- FERRARI CHALLENGE COPPA SHELL-AM CHAMPION
This will be awarded to the Driver ranked number one (1) in the overall Coppa Shell AM standings.
- DEALER CUP
This will be awarded to the Dealer ranked number one (1) based on total number of points from all entries (regardless of class) over the course of a season.
- SHELL GENTLEMEN'S CUP
This will be awarded to the Driver ranked number one (1) in the Gentlemen's Cup standings.
- SHELL-AM GENTLEMEN'S CUP
This will be awarded to the Driver ranked number one (1) in the Gentlemen's Cup standings.
- SHELL LADIES' CUP
This will be awarded to the Driver ranked number one (1) in the Ladies' Cup standings. The overall standings will be calculated based on the formula described in Article 23.
- SHELL-AM LADIES' CUP
This will be awarded to the Driver ranked number one (1) in the Gentlemen's Cup standings.

24.2 In case of a tie in the final Driver championship point standings, the tie shall be resolved according to the highest ranked Driver's record of first place points finishes, and then if necessary, the number of second place points finishes, and so on down to the last championship points position for the class. If a tie still remains, the tie shall be broken by the first to achieve the highest points finishing position in that season for that class.



25 Incidents and driver conduct

25.1 Incidents. "Incident" means any Driver who, in the sole opinion of the Race Director, is responsible for an incident where a car spins, or goes off track, or suffers a flat tire or other mechanical difficulty requiring it to pit directly for repairs, or an incident of contact resulting in a change of position, may be warned or penalized pursuant to Article 26, and such decision is conclusive.

1. Competitors involved in an incident with an impact during the practice, qualifying sessions, or race must be checked by Medical and a written medical clearance provided to IMSA Officials authorizing return to competition. They may not enter any subsequent event sessions without authorization from Medical and IMSA Officials. Crew members involved in an incident resulting in injury must also provide a written medical report of the incident at the time of the incident or as near to that time frame as possible.
2. The Driver will have to adhere to the instructions issued by the Ferrari Technical Staff related to the car's technical check.

25.2 Blocking. Any Driver who, in the sole opinion of the Race Director, moves in reaction, altering their line based on the actions of pursuing Drivers, or who selects a defensive line and then returns to a racing line between corners or sections of the racetrack, may be warned or penalized pursuant to Article 26, and such decision is conclusive.

25.3 Unjustifiable risk. Any Driver who, in the sole opinion of the Race Director, engages in any behavior deemed to represent an unjustifiable risk or reckless endangerment may be warned or penalized pursuant to Article 26, and such decision is conclusive.

25.4 Stopping and disabled cars. During an event, if a car is involved in an incident and/or is stopped on or near the racing surface and unable to continue to make forward progress, unless extenuating emergency conditions exist with the car (e.g., fire, smoke in cockpit, etc.), the Driver should take the following steps:

1. Communicate the condition of the Driver and car to Officials where possible;
2. Shut off electrical power;
3. Do not loosen, disconnect, or remove any Driver personal safety equipment until directed to do so by Officials;
4. After being directed to exit the car, the Driver must proceed as directed by Officials;

5. The Driver must not approach any portion of the racing surface;
6. The Driver must not approach another moving car.

25.5 Driver egress. A Driver exiting a car stopped in a location away from the racing surface should first communicate the condition of the Driver and car to Officials where possible, shut off electrical power, and only move directly to a protected location behind a wall, other barrier, or as directed, and must not approach the racing surface or other moving cars.

25.6 It shall be at the discretion of the Race Director if a Driver or Drivers involved in an incident shall be penalized.

25.7 The Driver will have to adhere to the instructions issued by the Ferrari Technical Staff related to the car's technical check after involvement in a collision or incident.

Unless it was completely clear that a Driver was in breach of any points of Article 25, any incidents involving more than one car will normally be investigated after the race.

26 Penalties and sanctions

26.1 Penalties assessed by the Race Director will be based on the Driver's on- or off-track actions in violation of the Ferrari Challenge Regulations, the IWSC Rule Book, and applicable laws, and will consist of "Stop and Go" penalties as defined by the current IMSA Regulations, time or lap penalties, disqualification or suspension from one or more events, fines, and/or forfeiture of a specified number of championship points as per these regulations. Where possible and appropriate, the Race Director will apply penalties following, rather than during, a session. For actions that endanger other Drivers, Crew, Workers, or Spectators, the Race Director will enforce immediate penalties. It shall be at the discretion of the Race Director if a Driver or Drivers involved in an incident shall be penalized.

26.2 The Race Director will not consider video footage from a Driver's personal on-board camera or any other external video source not immediately available in Race Control during the race in making decisions. After the race, the Race Director may review footage from the official IMSA in-car cameras. Furthermore, the Race Director will not consider reports from individual non-official observers.



26.3 The following penalties will normally be applied by the Race Director for specific violations. The Race Director may increase or decrease these penalties depending on the severity of the violation.

1. On track
 - a) Loss of Control
 - (i) A total of three (3) losses of control (i.e. spin, 4-off) during a practice session will result in that car being parked for the remainder of the session.
 - b) Single-car contact
For single-car-to-barrier contact (not as a result of car-to-car contact) during practice, qualifying sessions, or race, a Driver must contact the Race Director immediately following the session and will also result in that car being parked for the remainder of the session. Failure to do so may mean loss of the next session, practice or qualifying. The Race Director will determine the severity of the incident and will penalize the Driver depending on the severity of the contact and the Race Director's good judgement.
 - c) Car-to-car contact
 - (i) In practice, all Drivers involved must contact the Race Director immediately following the session. Failure to do so means automatic total loss of the next session, practice or qualifying.
In practice, a Driver determined to be at fault for incident responsibility will result in that car being parked for the remainder of the session and/or the next session.
 - (ii) A Driver determined to be at fault for incident responsibility during a race may be penalized an amount of time or number of laps by the Race Director following the race.
 - (iii) A Driver determined to be at fault for a second offense of incident responsibility during a race may receive a black flag, with a minimum of a 30-second penalty and a maximum of exclusion from the race.
 - (iv) A Driver deemed responsible for a first lap, first turn incident will start from Pit Lane at their next race.
 - (v) All Drivers involved in car-to-car contact during a qualifying session or a race must contact the Race Director immediately following the session. Failure to do so may result in further exclusion from the event.
 - (vi) For any two offenses on a single event weekend, a Driver will be placed on probation; for a third offense, a Driver

may be excluded from the following event.

- (vii) Ordinarily the overtaking Driver is responsible for making a safe pass. However, in cases where both Drivers are at fault, or the Driver being overtaken has attempted an inappropriate blocking maneuver, either both Drivers or the Driver being overtaken may be penalized for incident responsibility.
- (viii) In any of the above cases, if unable to apply the penalty at the event where it is incurred, the penalty may be enforced at the next event.
- (ix) The Race Director may apply any penalty during a race whenever the information available is sufficient to do so.
- (x) Guest Drivers who are not series regulars may be subject to more severe penalties in the event their inappropriate actions impact series Drivers.

2. Technical issues
 - a) Items that could contribute to the performance of the car - underweight, low ride height, addition or substitution of performance-related components (brake pads, gears, fuel, exhaust system, engine size, or specification) - will be subject to penalty as indicated below (see Ferrari Challenge Technical Regulations):
 - (i) After qualifying: loss of qualifying time.
 - (ii) After race: the Driver may be disqualified, including a loss of position and points.
 - b) Items that are not to factory standard as determined by the technical documentation but do not directly contribute to the performance of the car will be subject to penalty as indicated below:
 - (i) After qualifying: reprimand, must be fixed by race, and possible Dealer points penalty.
 - (ii) After race: a time penalty may be assessed and/or a Dealer points penalty.
 - (iii) Any evidence of tampering with or missing engine seals will be grounds for exclusion from the event at a minimum.

26.4 Any Driver whose car fails technical inspection at two events for improper preparation or violation of the Technical Regulations, or any Driver who is twice disqualified as a finisher for violation of these regulations, may be penalized by suspension from a specific number of future events, forfeiture of all points gained, and/or ineligibility to compete



further in the Ferrari Challenge. These penalties will be determined by the Challenge Committee.

26.5 The Challenge Committee may impose penalty points on a Driver. If a Driver accrues ten (10) penalty points, he or she will start from the back of the grid in the next race available. Each penalty point that exceeds will be applied toward a new Driver's counter, World Finals not included.

26.6 The Challenge Committee may impose additional point penalties on a Team for technical infractions. This will affect the Team's cup standings.

27 Protests and appeals

27.1 Protests against the actions of another Driver, or against another competing vehicle, must be filed in accordance with IMSA Regulations.

27.2 Appeals will be heard in accordance with IMSA Regulations, with the exception that the Appeals Board will be jointly appointed by IMSA.

27.3 Protests and appeals will not be accepted on any decision of an Official not specifically provided for in the Ferrari Challenge Regulations. These subjects include (but are not limited to) timing and scoring decisions, inspection decisions, and race procedure decisions.

27.4 Drivers, Team Managers, Coaches, or other Team personnel are strictly forbidden from appearing in Race Control while race sessions of any group are still in progress and without IMSA Official permission.

27.5 It is expected the Drivers, Team Managers, and Coaches will maintain a respectful and polite attitude toward Officials and their fellow Drivers at all times.

27.6 Individual Coaches have no right of appeal and are not invited at any time to be involved in any Driver dispute. The sole responsibility of a Coach is the guidance of a Driver's driving skills. The Coach must maintain a neutral and unbiased attitude at all times. Disrespect of this rule may result in expulsion.

Disrespect of any of the above regulations may result in time and/or point penalties up to fines.

28 Other situations

Any unforeseen situation during a race that is not covered by the Ferrari Challenge Sporting Regulations will be handled in accordance with the most current version of the IMSA WEATHERTECH SPORTSCAR CHAMPIONSHIP (IWSC) Sporting Regulations, which is available from the International Motor Sports Association, LLC (IMSA).

International Motor Sports Association International Motorsports Center
One Daytona Blvd. Daytona Beach, FL 32114
<https://www.imsa.com/competitors/>
Phone: 386.310.6500



1 Admitted cars

296 Challenge (and related updates).

2 General Principles

This Technical Regulation is in compliance with the FIA document - Appendix J 2 Article 277 of Appendix J of the Free Formula Technical regulations (Group E) WMSC 6.12.2020 (CATII-SH).

Anything not expressly authorized by these Technical Regulations is prohibited.

The official Ferrari documentation, which includes:

- the Spares Parts Catalogue,
- the Wiring Diagrams,
- the Technical Manual,
- the Technical Bulletins,
- the Technical Sheet SCT296 -1024,

covers anything not expressly explained by the present Technical Regulations. The Technical Bulletins that temporarily or permanently modify the Technical Regulation issued by Ferrari before an event and approved by the Stewards become an integral part of the regulations themselves.

The only work which may be done on the cars is normal maintenance or the replacement of parts damaged by wear and tear or in an accident. The permitted modifications and assembly limitations are specified in these Regulations. These aside, any part affected by wear and tear or accident may be replaced only by an original spare part. Any addition of a part or material is prohibited if not expressly authorized by the present regulations, the Technical Sheet or official Ferrari Technical documentation.

The Cars must always be identifiable by their:

- the Technical Sheet SCT296 -1024,
- the Technical Manual,
- the Spares Parts Catalogue,
- comparison with original production components,
- updated project drawings,
- updates as per Technical Bulletins.

The Competitor is responsible of ensuring that both car and the spares fitted to it are compliant and he must thus ensure they are in order before each race.

At any time during the event, Ferrari staff is authorized to ask competitors to remove any component from the car for general technical inspections. In this case, the cost of vehicle repairs will be incurred by the team.

3 Minimum weight / height requirements

MINIMUM WEIGHT = 1490 Kg (car + driver)

The minimum weight specified below must be considered as the sum of the car weight and the driver weight (helmet and HANS® device included).

For the verification of the minimum weight, the vehicle is considered with the prescribed amount of liquids in running order and with the fuel tank completely empty.

The fuel tank is considered completely empty if the fuel has been totally removed from the tank by using exclusively the dedicated fuel extraction socket for the emptying operation.

To reach the minimum weight it is mandatory to use ONLY the official ballast kit p/n 990277 and the ballast weights p/n 990294 (1,5 Kg) and/or p/n 990280 (3 Kg).

KERB: the minimum and maximum heights of the car has to be adjusted as follows.

The prescription must be respected on both sides, left and right.

FRONT: minimum 100 mm - maximum 112 mm

REAR: minimum 100 mm - maximum 114 mm

For high-speed tracks, the minimum ground clearance values may vary. For further details on the limit values for high-speed tracks, please refer to the dedicated technical documentation (Ferrari Workshop Manual and Pirelli PBook Manuals, and RCS web manager bulletins).

All height measurements above are to be considered from the master points to the ground with slick tyres at 1.8 bar pressure.



In case the car closes the session with rain tyres, the height check will be carried out with the rain tyres mounted on the car at the end of the session at 1.8 bar.

For further details please refer to Annex 2 of this document.

4 Engine

The engine must be without exception a production engine in all its parts. To ensure this, seals will be applied by Ferrari directly to ensure that no further work is done on it. Any necessary engine maintenance work / engine replacement is the direct responsibility of the Ferrari Official Dealership and/or the Ferrari importer. They must declare the reason for the engine maintenance/replacement and declare to the Technical Delegate of the Championship the new engine seal numbers following the instructions released by Ferrari S.p.A.

The Competitor will not be allowed to start the race if, during the pre-event technical scrutineering carried out by the Technical Scrutineers with technical support from Ferrari, the documentation and the number of the seals fail to comply with the regulations.

No part of the engine may be modified. No materials may be removed or added with the exception of those outlined in the present Regulations and/or the Technical Sheet SCT296-1024.

In the case of repairs made due to overheating and involving the dismantling of the cylinder heads, the team must inform Ferrari. However, no leveling work is permitted. Abrasive materials must not be used to clean the heads.

In agreement with the Stewards of the Meeting, the Organization reserves the right to pick the engine or other mechanical parts and send them to Ferrari S.p.A. for conformity checks.

In agreement with the Stewards of the Meeting, the Organization reserves the right to replace the ECUs (engine control units) at any time during the Event.

5 Electrical system

The diagnostic OBD plug must be always in working order to guarantee the connection of the official diagnostic tool to all the electronic control units of the car, so that the checks that will be requested by Ferrari and in agreement with the Stewards can be performed.

No unoriginal or unauthorized device can be connected to the OBD diagnostic sockets and to any can bus line of the car.

The electrical equipment must always conform to the original and no detail of the electrical system (cables, looms, connectors, etc.) can be changed or tampered with.

To carry out the checks on the conformity of the electrical system, the scrutineers and Ferrari technical staff can use any type of equipment, instrumentation and methods they deem appropriate (multimeters, additional cables, welders etc.).

If necessary, the scrutineers and Ferrari technical staff may request the transport of the vehicle at the manufacturer's premises for further checks.

6 Gearbox / transmission

The gearbox must be the one provided for by Ferrari and thus strictly stock in all its parts.

In agreement with the Stewards of the Meeting, the Organization reserves the right to pick the transmission unit and send it to Ferrari S.p.A. for conformity checks.

In agreement with the Stewards, the Organization reserves the right to withdraw the transmission control unit from the Car and replace it at any time during the event.



7 Wheels / tyres

Only slick or rain tyres supplied by Pirelli in the following sizes may be used:

Front slick	280/680 - 19" - DH
Rear slick	300/720 - 19" - DH
Front rain	280/680 - 19" - WH
Rear rain	300/720 - 19" - WH

Any chemical and/or thermal treatment of the tyres is prohibited. Cleaning the tyres after track sessions is permitted.

The Ferrari and Pirelli staff are authorized to inspect the tyres (condition and pressure) at any time during the race weekend.

The wheel rims have the following sizes:

Front	11" x 19"
Rear	12" x 19"

The Ferrari and the Pirelli staff are authorized to recall rims and to request the replacement of the valves if considered not suitable and adequate to run.

At the end of the race, tire sets need to be given back mandatory to Pirelli. An economic sanction may be applied to teams who do not respect this.

It is mandatory to have the Ferrari Challenge TPMS System always working correctly (telemetry data logged and available) during Free Practice, Qualifying sessions and Races.

8 Suspensions and setup

Under no circumstances, the negative camber can exceed the following negative values (decimals):

Front	-3,5°
Rear	-3,0°

For high-speed tracks (as defined by Ferrari), the maximum negative camber values may vary. For further details on the limit values for high-speed tracks, please refer to the dedicated technical documentation

(Ferrari Workshop Manual, Pirelli PBook Manuals, and RCS web manager bulletins).

According with the different track layouts, Ferrari, in collaboration with Pirelli, may communicate values of camber to respect different from the ones mentioned above.

Camber may be adjusted, within the permitted limits, by adding or removing the original Ferrari spacers between the suspension and the chassis, as described in the official Ferrari documentation and technical bulletins on the subject.

Original Ferrari spacers (1 mm, 2 mm, 3 mm, 4 mm, 5 mm - see official Technical Documentation) are admitted to adjust the shock absorber stroke.

It is possible to adjust the anti-roll bar end-link position between one of the two original holes.

It is not permitted to detach or remove the anti-roll bars.

The permitted original suspension and springs are as follows:

Front damper	cod. 987273
Rear damper	cod. 987279
Front spring K300	cod. 972065
Rear spring K220	cod. 750276

9 Pipes / wiring / heat shields

The positioning of all the cars various components must comply with the original layout as described in the technical information.

10 Frame and body

No part of the bodywork may be worked upon or modified. All parts must comply in terms of size, look and material to the original parts. The original position of any elements of the bodywork may not be modified in any way. Neither shall adhesive tape be applied to the profiles or bonnet, wheel arches, doors, etc.



It is not permitted to use rails, brackets and any kind of non-original material to change the seat position.

It is not permitted to carry out any strengthening work on the frame (welds, brackets, etc.) without the authorization of Ferrari S.p.A.

The maintenance operations to repair structural parts of the chassis must be carried out and supervised by personnel holding a certification of qualified aluminum welding to the standards requested by Ferrari.

11 Aerodynamics

Rear wing: The position of the rear wing must respect the following instructions (for more details please refer to Annex 2).

Angle of attack of the wing: it must be included in the range $+3^\circ$ to $+9^\circ$ (limits included).

The car must have the original wing supports. For the correct adjustment of the angle of attack please refer to the table in Annex 2 where you can find the correspondence between the signs on the wing supports and the angle of attack.

Wing height: with the car on a flat reference plane, the upper edge of the wing nolder must stay at ± 10 mm respect to the top of the roof, and this for any adjustment of the angle of attack within the admitted range.

Wing offset: with the car on a flat reference plane, the front upper edge of the wing nolder must be 1610 ± 10 mm far from the third stop spoiler for any adjustment of the angle of attack within the admitted range (for further details refer to Annex 2). The check is carried out in correspondence of the center of the wing .

The wing height and the wing offset are checked in the conditions in which the car finishes the session.

The wing section profile must not be modified.

The two side winglets cannot be modified in profile and section, and they must be always installed on the wing respecting the correct adjustment with reference to the angle of attack of the wing (see Annex 2).

The wing and its side winglets cannot be painted. Adhesives can be applied only on the side winglets and only on the top of the wing avoiding the leading edge area.

12 Cockpit

Pedals: it is forbidden to change the position of the pads for both the brake and accelerator pedal. For the correct position please refer to the official technical manual.

No modification can be made to the pedal assembly. Video recording systems: see article 18.

13 Windshield and side windows

Windshield: it is allowed to apply protective transparent films on the windshield. The layers applied must stay within the perimeter of the windshield and they cannot cover or close the outer edges between the windshield and the body.

Side window: it is allowed to apply air intakes on the side windows with the aim of reducing the temperature in the cockpit.

14 Fuel

It is compulsory for Competitors to use during Qualifying and Race only the fuel supplied by Shell at the racetrack. No other type of fuel or additives is permitted.

At the end of the Test and Free Practice sessions all the fuel must be drained from the car through the specific drain plug before filling up with official fuel.

Cooling of the fuel is prohibited in any form.

In case of a fuel check, Ferrari itself undertakes to transport the fuel sample, taken by the stewards or FNA technical staff in the presence of the competitor or his representative, to the testing laboratories.

The sample must be taken from the specific plug.



It is mandatory to use the original devices with handles, Ferrari p/n 183914 for refueling operations.

15 Brake system

The correspondence between the serial number of the brake discs stamped on the brake bell and those inserted in the FBO unit and readable with both diagnostic tool and telemetry must be guaranteed at all times.

16 Lubricants

It is compulsory for competitors to use only:

Engine oil:	Shell Helix Ultra SAE 5W-40
Gearbox oil:	Sell 498 F
Brakes oil:	Brembo Racing LCF 600 plus
Engine coolant:	Kemetyl Carix Premium Longlife (50% dilution)
Air cond. refrigerant:	R 1234yf
Air cond. compressor:	PS-D1

It is not permitted to use additives and to change the value of percentage in the above-mentioned liquids/oils. Samples of said lubricants and liquids will be taken during the championship for testing.

17 Safety equipment

The following safety equipment is compulsory under current legislation:

- roll-bar and relative protections,
- homologated 6-point safety harnesses,
- fire extinguisher,
- two hooks (front and rear),
- electric circuit breaker – main battery switch,
- FIA homologated seat,
- side head-nets,
- roll-cage predisposition to lift the car from the top/roof.

All safety devices listed above must be original.

The original number and position of the fire extinguishers may not be changed.

Drivers, during track sessions, must wear a HANS® collar. The use of a compatible helmet which meets the FIA Standard as specified in the Chapter 3, Appendix L of the Code is compulsory.

For further details, please consult the "Guide and installation specification for HANS® devices in racing competition" available at: www.fia.com, under FIA Sport – Safety – Safety Equipment - Driver's Equipment- Head Restraint.

18 Video recording equipment and loggers

The installation of any video camera inside the cockpit is done under the direct responsibility of the Team.

Any connected device that needs to log car data must be connected to the car only through the specific connector placed behind the driver seat.

The connector supplies the power and a private CAN BUS line, separated from the car CAN line, providing the data most commonly used by the aforementioned devices.

Video cameras are prohibited if mounted outside the vehicle unless specifically authorized by Ferrari

Any device connected to the car must still comply with the conditions specified in Article 5 and therefore no modification of the electrical system is permitted.

19 Telemetry / diagnostic tools

Telemetry systems different from the original or which provide redundant data to the original system are not permitted.

Diagnostics must be carried out only with the official diagnostics system and the original telemetry system. The official telemetry data and the data acquisition table must be those of the original system as well.



All the data (diagnosis, telemetry, video logger) must be always available to the Ferrari technical staff and to the Race Direction.

The marshalling kit must always operate correctly for a car to be admitted to the official sessions.

20 Organization of the assistance

Each team entered in our official events must be represented by an official Ferrari dealer.

The pairing between the team and the Official Dealer will have to be communicated and updated by the team entered at the Championship.

The team will have to address all the information requests to correctly manage the car to the Official Dealer.

The Official Dealer is responsible to support the team ensuring its work is executed correctly both on track and at the workshop.

21 Final instructions

Ferrari reserves the right to modify at any time, with the prior approval of the ACI Sport, the clauses and articles of these regulations if deemed necessary to the success of the Ferrari Challenge.

In the case of any protests or doubts, the Italian version of the Regulations shall prevail over the English version.

When entering the Championship or an individual Race, Drivers/Competitors are also responsible for ensuring they complete the permanent technical scrutineering proxy.



ANNEX 1
Coordinated Advertising

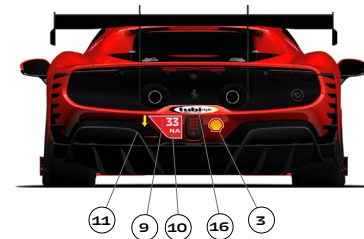
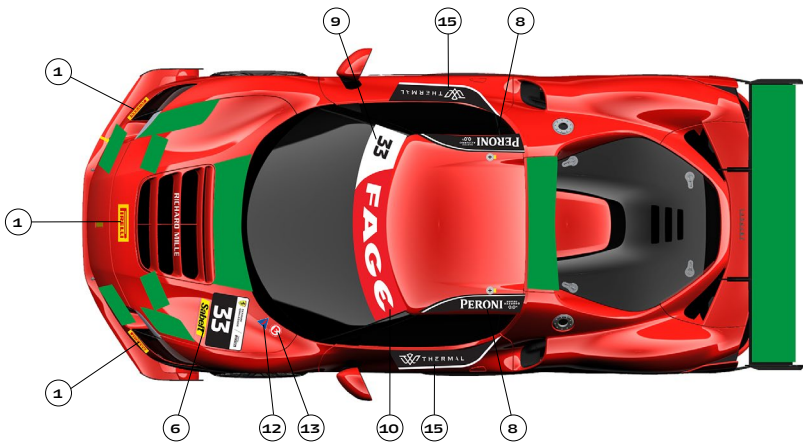
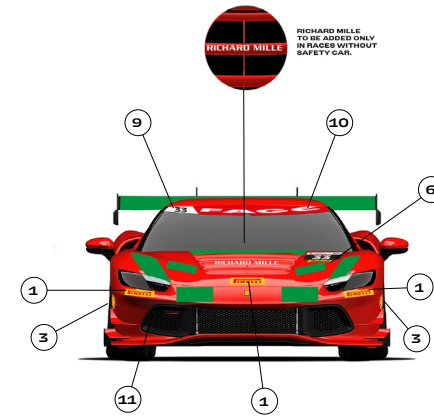
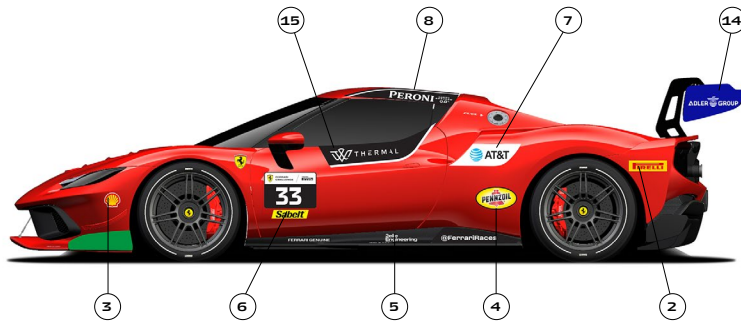

Green Spaces can be used by teams, but Ferrari reserves the right to use them for additional partners during the season.



33 Sabell **33 Sabell** **33 Sabell** **SABELT** 26,7 x 5,9 cm

CAR ROOF 42 x 6,7 cm

PERONI **PERONI**

SIDE 26 x 8,49 cm

AT&T **AT&T**

CAR ROOF 42 x 6,7 cm

BACK 30 x 9,5 cm

THERMAL **THERMAL**

UNDER HEADLIGHTS 22,5 x 6,4 cm

PIRELLI **PIRELLI**

FRONT + SIDE 26,4 x 7,5 cm

PIRELLI **PIRELLI** **PIRELLI**

REAR WING END PLATE 35,2 x 7,5 cm

ADLER GROUP **ADLER GROUP**

SIDE 24,8 x 14,25 cm

PENNZOIL **PENNZOIL**

FRONT + BACK 11 x 10,2 cm

SHELL **SHELL** **SHELL**

GILLS 36,9 x 2,8 cm (Only for Races without Safety Car) **RICHARD MILLE**

WINDSHIELD 85x11 cm

33 FAGE **33 FAGE** **33 FAGE** **33 FAGE**

NUMBERS FRONT & BACK

1 2 3 4 5 6 7 8 9 0 | H 7.5 cm

1 2 3 4 5 6 7 8 9 0 | H 7.5 cm

BACK

33 NA **33 NA** **33 NA** **33 NA**

NUMBERS FOR THE NUMBER PLATES

1 2 3 4 5 6 7 8 9 0 | H 13 cm

2 ELLE 16,4 x 2,7 cm

FERRARI GENUINE **Zelle Engineering** **@FerrariRaces**

FERRARI GENUINE **@FerrariRaces** **Zelle Engineering**

↑ ↑



Ref.	Q.ty	Logo	Color
1	3	Pirelli (big)	
2	2	Pirelli (small)	
3	3	Shell (small)	
4	2	Pennzoil	
5	2	Zelle-engineering	
6	3	Sabelt (plates) + race number (big)	
7	2	AT&T	
8	2	Peroni 0.0%	
9	2	Race number (small)	black or white
10	1	Fage / Windshield / Class	P (red) P-AM (white) S (yellow) S-AM (black)
11	2	Towbar	
12	1	Battery	
13	1	Fire extinguisher	
14	2	Adler	
15	2	The Thermal Club	
16	1	TubiStyle	

- 1) The official championship livery stickers can be collected at each round from the Corse Clienti Team.
- 2) The minimum distance between the stickers of the institutional sponsors and the stickers of the team's sponsors has to be 50 mm.
- 3) Affixing stickers (with the exception of the institutional ones) on the front and rear windows is prohibited.



ANNEX 2
Aerodynamics & setup



TABELLA CORRISPONDENZA ANGOLI REALI VS ANGOLI REGOLAZIONE INDICATI

ANGOLO REALE	INDICE REGOLAZIONE
+3°	-3
+4°	-2
+5°	-1
+6°	0
+7°	+1
+8°	+2
+9°	+3



Ref on chassis:
hole center of machined lower face

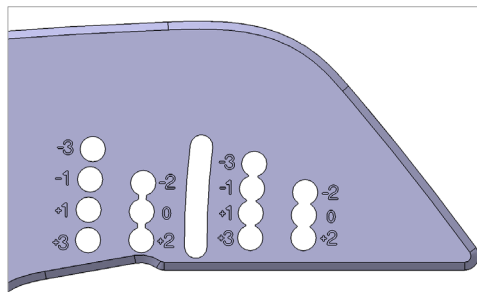
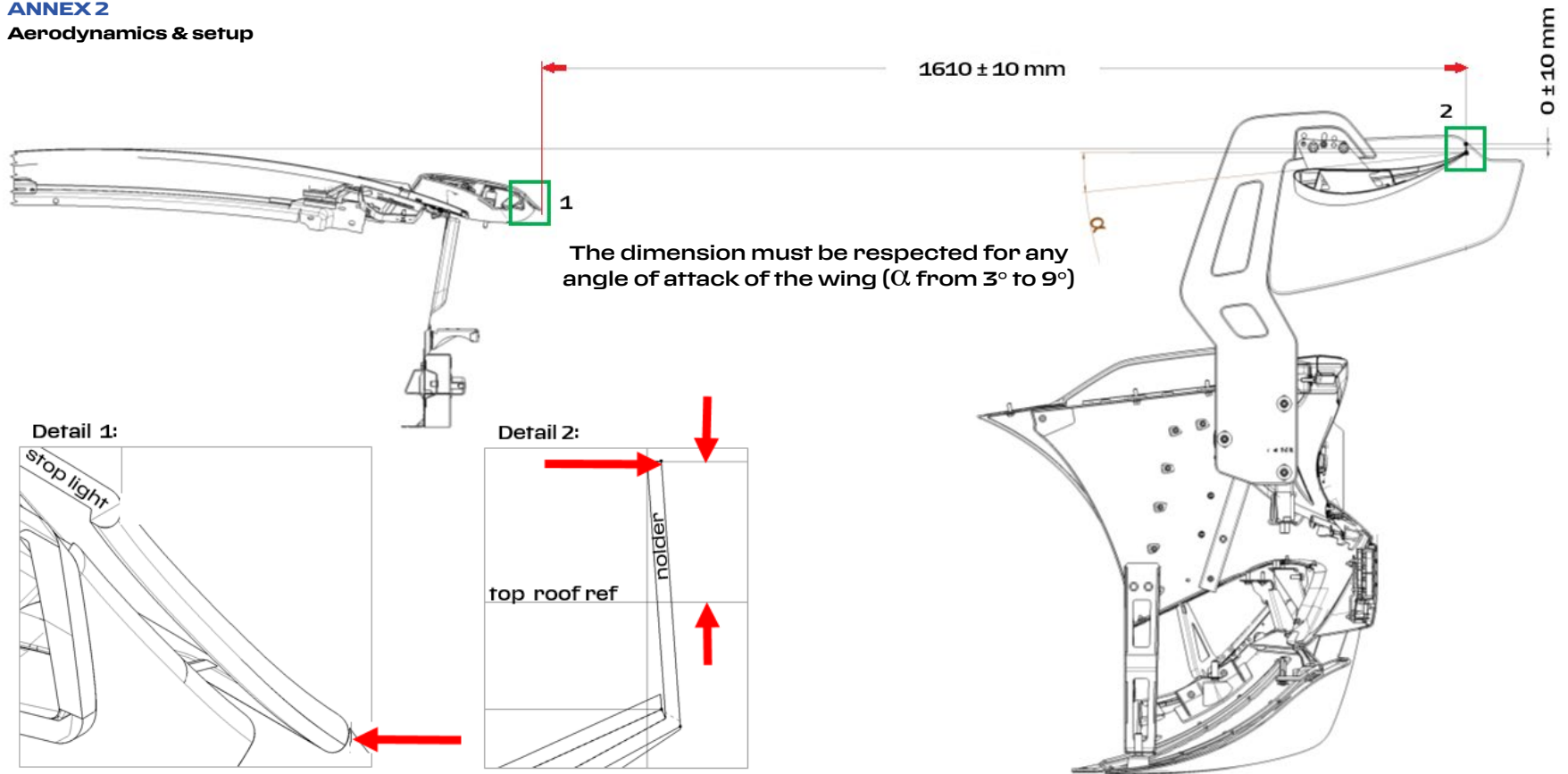
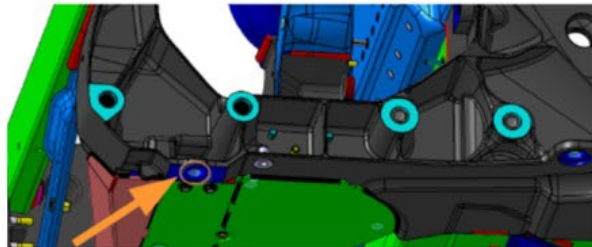
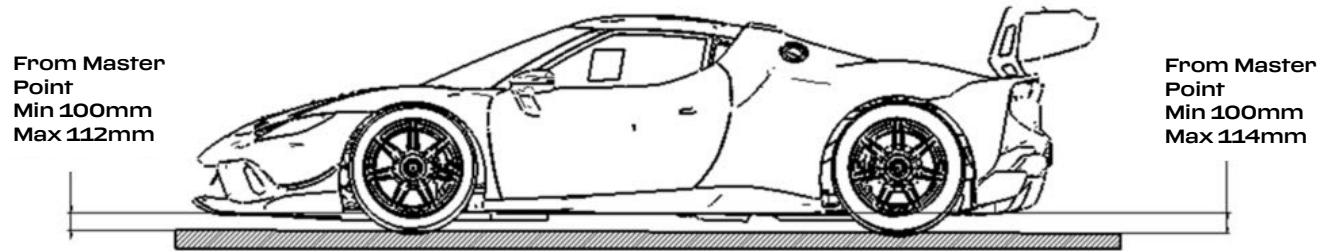
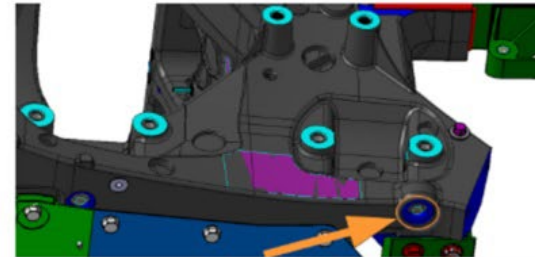

Ref on chassis:
hole center of machined face





PROTECTIVE EQUIPMENT IMSA APPROVED

Protective Equipment for Driver & Crew Members						
Position	Fire Suit	Underwear	Accessories: Balaclava, Gloves, Socks, Shoes	Helmet	Helmet Removal Device	FHR
Driver	FIA 8856-2000 FIA 8856-2018 SFI 3.2A/5 SFI 3.4/5	FIA 8856-2000 FIA 8856-2018 SFI 3.3	FIA 8856-2000 FIA 8856-2018 SFI 3.3	Art 21.1.1 FIA 8860-2010 FIA 8860-2018	Art 21.1.2 Eject Stand21 Lid Lifter	Art 21.1.3 FIA 8858-2002 FIA 8858-2010 SFI 38.1
Refueler Vent Operator Fire Bottle	FIA 8856-2000 FIA 8856-2018 SFI 3.2A/5 SFI 3.4/5	FIA 8856-2000 FIA 8856-2018 SFI 3.3	FIA 8856-2000 FIA 8856-2018 SFI 3.3	Art 21.1.5 Fire Rated: FIA SFI SNELL (SA)	Not Applicable	Not Applicable
Over the Wall Crew	FIA 8856-2000 FIA 8856-2018 SFI 3.2A/5 SFI 3.4/5	FIA 8856-2000 FIA 8856-2018 SFI 3.3 Optional	FIA 8856-2000 FIA 8856-2018 SFI 3.3	Art 21.1.6	Not Applicable	Not Applicable
	SFI 3.2A/3 SFI 3.4/3 SFI 3.2A/1 SFI 3.4/1	FIA 8856-2000 FIA 8856-2018 SFI 3.3 Mandatory				
Paddock Refueling Transfer of Fuel "Deadman" Valve	FIA 8856-2000 FIA 8856-2018 SFI 3.2A/5 SFI 3.4/5	FIA 8856-2000 FIA 8856-2018 SFI 3.3 Optional	FIA 8856-2000 FIA 8856-2018 SFI 3.3	Art 21.1.7 Optional	Not Applicable	Not Applicable
	SFI 3.2A/3 SFI 3.4/3 SFI 3.2A/1 SFI 3.4/1	FIA 8856-2000 FIA 8856-2018 SFI 3.3 Mandatory				

21.1.1. Modification (drilling of holes, etc.) is prohibited. Helmet must be of the 'full face' design.

21.1.2. Drivers must have the "Eject Helmet Removal" kit or the Stand 21 "Lid Lifter Balaclava" installed in their helmets.

21.1.3. FIA homologated items are no longer valid for IMSA use after December 31 of the calendar year, ten (10) years after the manufacture date on the FIA label; or, after December 31 of the FIA label year of expiration. A manufacturer's item may fail inspection due to condition at any time. FIA 8860-2010 helmets without a date of manufacture (pre-2013) are prohibited.

A. FIA 8856-2000 and SFI 3.2A/5 homologated items shall no longer be valid for use in IMSA after December 31, 2029.

21.1.4. Evaporative-loss Freon cool suits are prohibited.

21.1.5. (SSR) For over the wall crew in the pit lane, fire suits, underwear, accessories and helmets as listed above are not required for Ferrari Challenge North America.



TIRE REPLACEMENT PROCEDURE

Moving forward for the rest of the season the following form will need to be compiled to request the use of a "Joker" tire/s.

This form will need to be emailed to the following people:

- Kyle.Lentine@Ferrari.com
Jason.Bills@Ferrari.com
Kelly.Stoker@ferrari.com
Manuel.Marchi@Ferrari.com
tsnyder@imsa.com
dsampson@imsa.com

The following form is mandatory. Failure to complete the form below will prevent the aforementioned vehicle from being approved for use.

After the report is approved, FNA technical will notify IMSA of the change.

Thank you for your cooperation.

Date: Time: Circuit:

I, the undersigned Competitor / Driver:

Last Name/ Name: Car #:

Dealership:

Is requesting the use of joker tire/s QTY: for VIN:

Tire to be replaced: Front Left Front Right Rear Left Rear Right

Tire Type: From Session: Q1 Q2 R1 R2

Reason for the replacement:

Picture of the technical issue:

Empty box for technical issue picture

Empty box for technical issue picture

Signature



CAR REPLACEMENT PROCEDURE

Moving forward for the rest of the season the following form will need to be compiled to request the use of a replacement car (T-car).

The form will need to be emailed to the following people:

Kyle.Lentine@Ferrari.com

Jason.Bills@Ferrari.com

Kelly.Stoker@Ferrari.com

Manuel.Marchi@Ferrari.com

tsnyder@imsa.com

dsampson@imsa.com

The following form is mandatory. Failure to complete the form below will prevent the aforementioned vehicle from being approved for use.

After the report is approved FNA technical will notify IMSA of the change.

Thank you for your cooperation.

Date: Time: Circuit:

I, the undersigned Competitor / Driver:

Last Name/ Name: Car #:

Dealership:

Is requesting to replace VIN: (Vehicle has been damaged beyond repair)

With the use of a "T car" VIN:

Starting from: Q1 Q2 R1 R2

Pictures of the damaged car:

Signature



races.ferrari.com