

# 2026 TECHNICAL REGULATIONS

Revision Date: 05/13/2026



Series:

**IMSA VP RACING SPORTSCAR CHALLENGE**



Class:

**M2**



Sanctioned by:

**INTERNATIONAL  
MOTOR SPORTS  
ASSOCIATION**

One Daytona Blvd.  
Daytona Beach, FL 32114  
(O) +1 (386) 310-6500  
(F) +1 (386) 310-6695  
[www.imsa.com](http://www.imsa.com)



## 1. Technical regulations of the series

### 1.1 Overview of the groups/classes

The only cars eligible for competition in the BMW M2 Cup are BMW M2 Racing cars that conform to the technical requirements of these Technical Regulations.

The series production BMW M2 Racing model serves as a basis for the car.

### 1.2 Basis for the Technical Regulations

- These Technical Regulations
- G87\_M2Racing\_Technical\_Customer\_Manual in the latest version (hereinafter also referred to as the “Manual”)
- Electronic Parts Catalogue of BMW AG for the BMW M2 Racing (hereinafter also referred to as the “EPC”)

### 1.3 General/preamble

**Everything not explicitly permitted under these Technical Regulations is prohibited. Permitted modifications must not result in any unauthorised modifications or breaches of the Technical Regulations.**

The aim and purpose of these Technical Regulations is to allow every participant to be competitive in their class without requiring investment to modify or develop the vehicle.

As a rule, the EPC of the BMW M2 Racing defines the competition car. Deviations from this definition must be approved under these Technical Regulations or they are deemed to be inadmissible.



## 1.5 General regulations, permitted modifications and installations

The BMW M2 Racing must comply with these Technical Regulations at all times during an event.

It is the responsibility of the participants/entrants to ensure that the car is only operated if it is in perfect technical condition and complies with IMSA regulations at all times.

The only work that is permitted on the car is work that constitutes regular servicing or the replacement of worn parts or parts with accident damage.

Modifications and installations may only be made within the framework defined below. Any part worn through use or damaged due to an accident may only be replaced by an original part identical to the worn or damaged one.

Standard mountings such as nuts, bolts, washers, spring washers, wave washers and splint pins may only be replaced by standard parts corresponding to the original form. It must be ensured that the correct thread types, sizes and pitches are used (for example M8 x 1.25).

## 1.6 Minimum car weight and ballast

The series organiser shall provide a weighbridge to measure the weight of the car and the driver. It is deemed to be the 'official weighbridge'.

The official weighbridge is located in the series' scrutineering tent or at another location intended for this purpose.

If a car loses a part during free practice qualifying or a race, the weight of said part can be taken into consideration in terms of the car weight. The Stewards, in consultation with Scrutineers, have discretion to determine whether and which lost parts are considered when weighing the car.

### Minimum weight:

The minimum car weight is 1565 kg (excluding the driver).

The weight of the car must be equal to or higher than the minimum car weight at all times during the event. The car is weighed in the as-raced condition without the driver and with an empty fuel tank. Operating fluids may not be topped up prior to weighing.

If the car was damaged during competition, the weight of any parts lost as a result may be considered at the discretion of IMSA.



## **Ballast:**

Ballast may be added to the car to meet minimum weight requirements. As described in the EPC, this ballast must consist of fixed, uniform blocks and be attached to the floor of the passenger compartment using the ballast box base plate (part no. 8 324 128).

### **1.7 Displacement factor for turbocharged engines**

n/a

### **1.8 Exhaust regulations**

Cars must be equipped with a catalytic converter per the EPC.

### **1.9 Noise regulations**

The maximum permitted noise limits per the IMSA Sporting Regulations must be respected.

### **1.12 Fuel and, if applicable, control fuel**

The only permitted fuel is IMSA 100 by VP Fuels. No additives are permitted.

No changes to the designated fuel are permitted. For example, no substances may be added, removed or modified in terms of their concentration.

Fuel may only be cooled using unmodified ambient air during the event.

All deviations to these regulations are subject to the approval of BMW Motorsport.

#### **a) Fuel checks**

Fuel samples may be taken by the Scrutineers at any time during the event.

### **1.13 Technical definitions**

As defined by these Technical Regulations and the IMSA Sporting Regulations.



## **2. Special technical regulations**

### **2.1 General**

In addition to the Technical Regulations pursuant to Section 2 of these series specifications, the following special technical regulations also apply.

The cars must conform in full to the G87\_M2Racing\_Technical\_Customer\_Manual in the latest version as well as the current electronic parts catalogue, both of which describe the condition of the car as delivered. Exceptions to this are modifications for safety reasons at the discretion of the series organisers, which are to be made to all cars.

Permitted modifications must not result in any unauthorised modifications or breaches of the Technical Regulations.

### **2.2 Engine**

The engine is delivered by BMW as a sealed unit.

No modifications may be made to the engine or any engine parts.

Details of the engine seal and all sealed parts can be found in the latest version of the G87\_M2Racing\_Technical\_Customer\_Manual.

The Scrutineer must be informed in advance of the replacement of any sealed parts. The instructions of the Scrutineer are to be followed without exception. See Section 2.15.

### **2.3 Exhaust system**

The exhaust system described in the EPC is to be used. The additional muffler, see Section 1.9, is not permitted. Only the parts listed in the EPC and in the latest version of the Manual may be used for the installation and operation of the exhaust.

### **2.4 Transmission**

The gearbox and differential are delivered as non-sealed units. No modifications may be made to the gearbox or differential.

### **2.5 Brakes**

The entire braking system and all brake parts are to be procured exclusively through BMW.

The braking system is different to the standard version of the car and is defined by the EPC.



Driving aids (ABS, DSC and MDM) have been specially designed for use on the racetrack and may not be modified by the entrant/driver.

The car must be run with the braking system and brake wear parts defined in the EPC.

Brake pads CANNOT be chosen at will.

The following brake pads must be used on the car:

- Front axle: Pagid RSL-1, part no.: 8 889 736
- Rear axle: Pagid RSL-19, part no.: 8 884 689

Brakes may only be cooled in the manner defined in the EPC.

## 2.6 Steering

The steering is defined by the EPC and must be installed in unmodified form together with all components.

## 2.7 Suspension

The suspension has been modified for racing and is defined by the EPC. It may not be modified as a rule, with the exception of the following adjustments, which may be made for set-up purposes:



- Adjusting the track on the tie rod.
- Adjusting the camber in the strut bearings on the front axle (see Manual) and the eccentric screws on the rear axle (see Manual).
- Adjusting the ride height on the shock absorber.
- Adjusting the roll stabilisers at the intended junction points.
- The roll stabiliser (front and rear axles) must NOT be disabled.

All parts used on the car must be listed in the EPC and must be procured from BMW.

The compensation springs, assister springs and bump stops are therefore standardised parts. Modifications to parts, such as modifying the shock valves, are expressly forbidden.



All adjustments must be within the defined tolerances.



**Shock absorbers:**

Shock absorbers		
	Front	Rear
Type	HYDRAULIC / GAS	HYDRAULIC / GAS
Make	KW	KW
Typical series number	5B5B015 (LH) / 5B5B016 (RH)	5B5B018
Gas tank	NO	NO
Volume of gas tank	(No Gas Tank) N/A cm3	(No Gas Tank) N/A cm3
Maximum open length	480.3 mm DAMPER BOTTOM TO CONTACT SURFACE BODY	472.9 mm UNIBALL CENTER TO UNIBALL CENTER
Minimum closed length	381.8 mm DAMPER BOTTOM TO CONTACT SURFACE BODY	380.9 mm UNIBALL CENTER TO UNIBALL CENTER
		

(Figures: Shock absorber dimensions)

Compensation springs/springs:

Compensation Spring		
	Front	Rear
	Main	Main
Marque/Type of spring	<b>COIL</b>	<b>COIL</b>
Material	<b>STEEL</b>	<b>STEEL</b>
Diameter of wire	<b>4.8 X 7.5 +/- 0.2 mm</b>	<b>4.0 X 7.0 +/- 0.2 mm</b>
External diameter	<b>76.5 + 1.0 mm</b>	<b>65.5 + 1.0 mm</b>
Number of coils	<b>4.25</b>	<b>4.5</b>
Weight	<b>216 +/- 10 g</b>	<b>156 +/- 10 g</b>
Maximum free length	<b>60 mm</b>	<b>60 mm</b>
Stiffness	<b>20 N/mm</b>	<b>20 N/mm</b>
		

Springs Set 1		
	Front	Rear
	Main	Main
Type of spring	<b>COIL</b>	<b>COIL</b>
Material	<b>STEEL</b>	<b>STEEL</b>
Diameter of wire	<b>12.5 +/- 0.2 mm</b>	<b>12.5 +/- 0.2 mm</b>
External diameter	<b>87 +/- 2.0 mm</b>	<b>76.75 +/- 0.5 mm</b>
Number of coils	<b>5.3</b>	<b>6.9</b>
Weight	<b>1104 +/- 10g</b>	<b>1264 +/- 10g</b>
Maximum free length	<b>140 mm</b>	<b>170 mm</b>
Stiffness	<b>160 N/mm</b>	<b>170 N/mm</b>
		

(Figures: Compensation spring/spring dimensions)



## 2.8 Wheels (disc + rim) and tyres

Only approved rims as defined in the EPC may be used in the BMW M2 Cup (part no.: 5 B69 0D7).

These rims must be procured from BMW.

The approved tire supplier for this Class is Michelin.

Tires must be used in accordance with IMSA Sporting Regulations Attachment 3.

## 2.9 Bodywork and dimensions

### a) External bodywork (incl. windows)

Window stickers are governed by the event organiser. Safety film may to be applied to the windows on the driver's side and passenger's side doors as described in the Manual. Adding openings to the windows for ventilation purposes is not permitted.

Closing or masking openings or panel gaps is generally not permitted. In the case of provisional repairs made during an event, openings or panel gaps in the direct vicinity of the damage may be masked if necessary to save time. The permissibility of repairs is at the discretion of the IMSA.

If unusually cold temperatures give rise to the need to close ventilation holes, this work is subject to the express approval of the IMSA.

Transparent, non-tinted tear-off strips may be affixed to the windscreen for protection. These tear-off strips must not be marked and must not contain any air bubbles obscuring the view of the driver.

### b) Cockpit

No individual ventilation tubes are permitted.

A drinks system may be installed provided it is mounted to a fixed point and the bracket can withstand acceleration forces of up to 25 G. The decision as to whether the bracket is sufficient lies with the Scrutineer/Chief Scrutineer.

The pedal system may not be changed, with the exception of the application of grip tape.

The seat, seat console and seatbelts must conform to the EPC and may only be procured from BMW.

The standard steering column adjustment is to be retained and must conform to the EPC at all times.



All covers in the interior are to be used as described in the EPC.

If an entrant registers a driver who is unable to use the seat defined in the EPC without safety concerns due to their physical condition, BMW may grant approval for another seat with an associated console on the basis of a corresponding written application.

Evidence that the seat defined in the EPC cannot be used is to be provided to BMW by way of a seat fitting. Approval will be granted only if the BMW identifies no safety risk.

Such an approval is driver-specific and therefore only applies when the respective driver is participating in an event. The alternative seat and console must conform to Article 253 Appendix J and must be presented for inspection during scrutineering.

There are no specific formal requirements for such an application; however, the application must include the name and licence number of the driver as well as the manufacturer and serial number of the alternative seat and console.

c) **Additional accessories**

Accessories listed in the EPC may be installed and can be compensated for through the ballast specified in the foregoing Article 1.6 of these Technical Regulations. Accessories must be explicitly permitted in these Technical Regulations.

## 2.10 Aerodynamic devices

Aerodynamic devices are the front splitter and the rear wing.

The rear wing is not fitted to the car as standard and must be installed, together with all specified components, in the manner described in the Manual and the EPC.

The position of the rear wing is defined as follows:

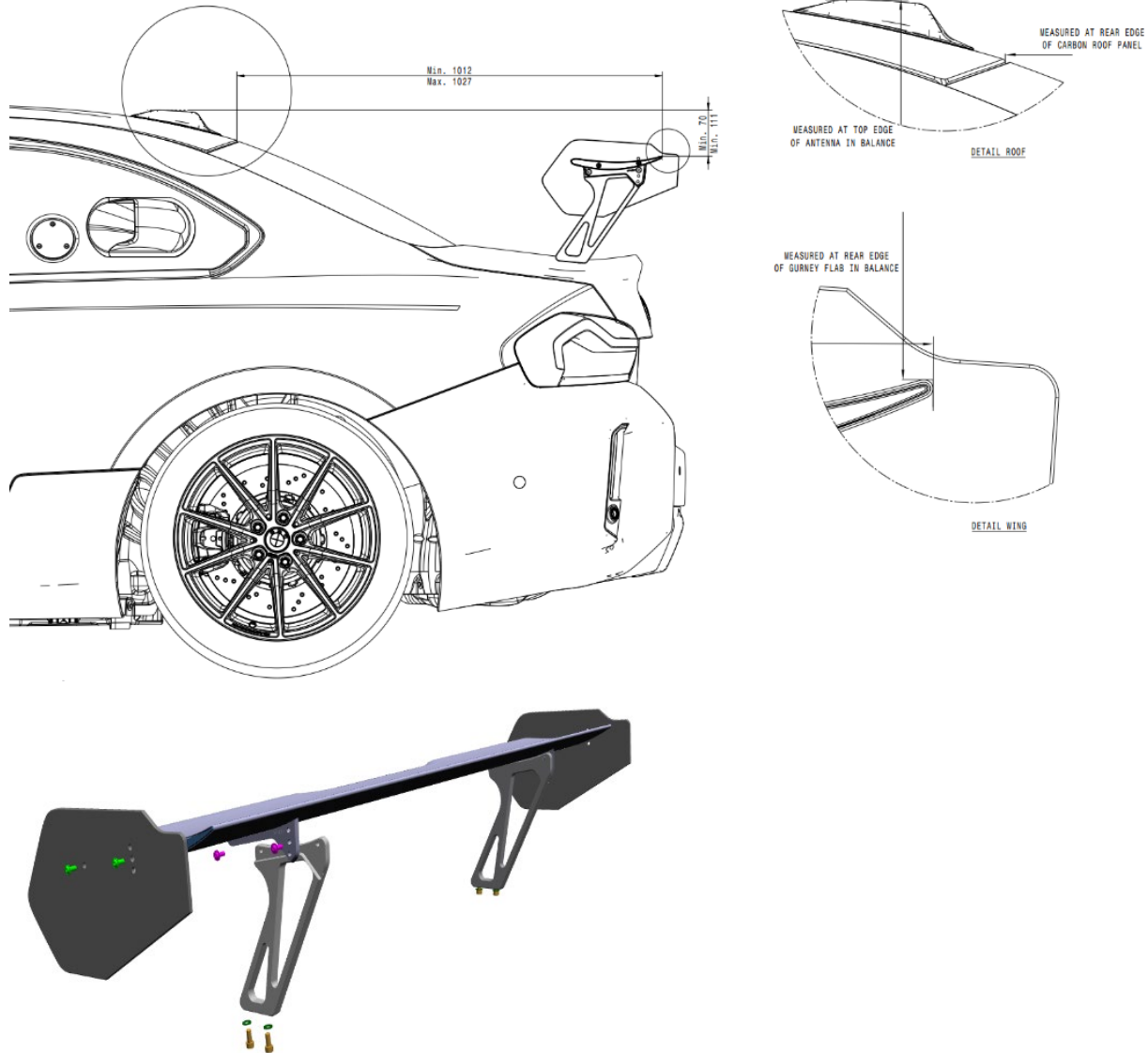

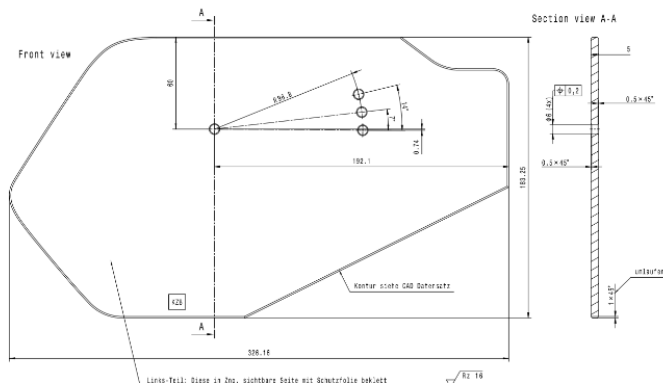

(Figures showing the position of the rear wing)

## 2.11 Electrical equipment

MoTeC C125 display with data logger is to be used, as defined in the EPC (part no.: 5 B8E B17). It is fitted to the car using the BMW Motorsport bracket (part no.: 5 B76 DA6). The electrical connection to the car is provided through the wiring loom, part no.: 5 B91 B01 – MoTeC loom, incl. 5 B91 B02 (RJ45 connector). A MoTeC L10 GPS antenna, part no.: 5 B92 099 is to also be installed in the car and connected to the wiring loom. The technical specifications (options) and configuration of the MoTeC C125 as well as the correct installation position are defined in the latest version of the G87\_M2Racing\_Technical\_Customer\_Manual.

The data from the data logger is used by BMW and/or the Scrutineer/Chief Scrutineer to review the conformity of the Cup cars.

The data from each participant is not published and is only used internally.

Data that is collected and reviewed by BMW and/or the Scrutineer/Chief Scrutineer includes the throttle valve position, engine speed, car speed, gear, turbocharger pressure, turbocharger air temperature, lambda, ignition angle and injection volume.

Any deviations in these values outside of the tolerances defined by BMW are deemed to be attempted manipulation.

The participant is responsible for ensuring that all sessions are logged flawlessly (all laps driven) and that the data logger is functioning properly at all times during an event. Should the logger itself or a component of the system (sensor, wiring, etc.) be damaged or doubts arise as to whether it is functioning properly, BMW and IMSA are to be notified immediately in writing.

If data is lost or incomplete, this may result in a penalty.

Repairs to the wiring loom may only be performed in consultation with the BMW and IMSA.

The event organiser may stipulate an additional boost pressure sensor. The boost pressure sensor must be procured as a kit from emotag (emotag federal pressure sensor kit 3.5 bar).

The following parts from the EPC are required for the installation:

- 5 B91 A35, scrutineering pressure sensor loom
- 5 B85 565, air intake adapter
- 5 B8E 818, boost pressure cable harness D04
- 5 B8E AD8, bracket boost pressure sensor

These parts are to be installed in accordance with the latest version of the Manual.

Participants shall hand in recordings of their data stored on a USB stick within 30 minutes after the end of the relevant sessions (qualifying and the race) to the Technical Inspection area.

Lighting is to be installed according to the latest version of the M2 Racing Manual.

Participants are permitted to use their own camera systems; no CAN interface is available. If used, camera must be installed in the following location: **LOCATION TBD**

## 2.12 Fuel system

The entire fuel system is to be installed according to the latest EPC and may not be modified.

## 2.13 Lubrication

All permitted operating fluids (oil, grease, coolant and brake fluid) are listed in the EPC, with the exception of the engine oil.

The only permitted engine oils are those listed in the latest version of the Manual.

The entrant/participant is obliged to provide detailed information in writing on the operating fluids it uses (type, name, specification, manufacturer) at the request of IMSA or BMW.

## 2.14 Data transfer

No data transfer between the car and the outside world is permitted, with the exception of the following:

- Radio communications
- TV cameras mandated by the event organiser
- Marshalling systems mandated by the event organiser
- GPS system (→GPSauge)
- Transponder for timing/noise measurement

No telemetry systems are permitted as a rule. No transfer of data between the car and the team is permitted while the car is out on the circuit.

The use of the data interface for the GPSauge M-GPSA- K1 or identical systems is permitted if this system is mandated by the event organiser. Such systems must be installed in accordance with the event BMW's instructions. Power must be provided via the 12V in-car supply.

Any other systems mandated by the event organiser that result in data transfer are subject to the approval by the IMSA.

### **Special equipment:**

A conversion kit for physically disabled drivers may be used subject to approval by BMW and IMSA.

All approvals are to be presented at scrutineering. It should be noted in this regard that approval is vehicle-specific and may only be used at the respective event in combination with the nominated driver in this car.

## 2.15 Repair, sealing and labelling of parts by BMW

Details of the engine seal and all sealed parts can be found in the latest version of the G87\_M2Racing\_Technical\_Customer\_Manual.

The Scrutineer must be informed in advance of the replacement of the parts. The instructions of the Scrutineer are to be followed without exception.

## 2.16 Track width

- Front track width: max. 1,662 mm
- Rear track width: max. 1648 mm

**Measurement instructions:**

The car is measured at the reference area. Reference is made to Article 1.6 (weighbridge) with regard to the reference area. Tyre pressures will be set to the reference pressure (2.0 bar) for the measurement procedure.

On the axle that is being measured, a 90° angle is positioned on the ground directly beneath the centre of the axle and placed flush against the inner and outer sidewalls of each tyre. These four positions are marked on the ground.

The distance between the markings (outer to outer and inner to inner) is measured, added together and halved. The resulting value is the track width.

**2.17 Ride height**

Ride height is measured with an empty fuel tank and without a driver.

No part of the car may be in contact with the ground when the tyres on one side of the car are not inflated. This test is to be carried out on a level surface with a race-prepared car and a driver on board.

The areas designated in the following figure are used as measurement points on the car:

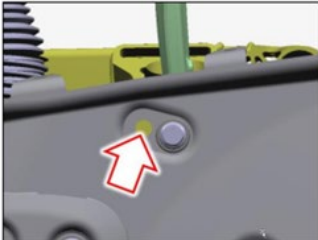
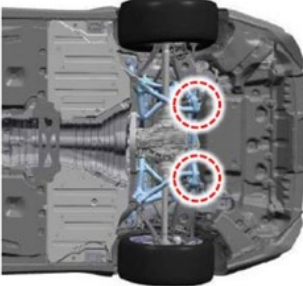
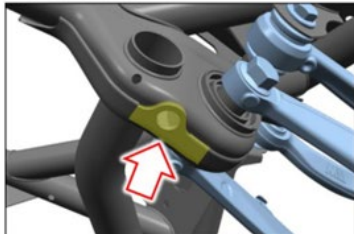
	Front	Rear
<b>Minimum height of the chassis from the ground</b> Without fuel	<b>113 mm</b>	<b>133 mm</b>
<i>Reference points on chassis</i>	 <p style="text-align: center;"><b>Front measuring points on the front axle carrier</b></p>  <p style="text-align: center;">Front measuring points</p>	 <p style="text-align: center;"><b>Rear measuring points on the rear axle carrier</b></p>  <p style="text-align: center;">Rear measuring points</p>

*(Figures – Car underbody and measurement points to determine ride height)*



Ride height must be at least 113 mm at the front axle and 133 mm at the rear axle at all times during an event.

Tyre pressures will be set to the reference pressure (2.0 bar) for the measurement procedure.

The tyres fitted at the time of the inspection are to be used for the ride height measurement. All measurements are taken on slick-type tyres.

If one or more tyres are unable to maintain the required pressure due to damage, the tyre(s) in question may be replaced.

## **2.18 Control units and software version**

The control software and hardware may be inspected at any time by BMW and must always conform to the latest version of the Manual or the version defined by bulletin to the teams. If this is not the case, it will be reported automatically to the Stewards at the event and to BMW.

BMW is entitled to update or replace the software version or the control hardware at any time. The entrant /driver (participant) is not permitted to overwrite or modify any data or program versions in the control units.

## **2.19 Air jack system**

Air jack system is mandatory.

All parts listed in the EPC are to be installed in accordance with the instructions in the latest version of the G87\_M2Racing\_Technical\_Customer\_Manual.

## **2.20 Miscellaneous**

### **On-board Series camera system:**

Each car may be equipped with a camera by IMSA.

If necessary, the recordings may be provided to the series organiser or event organiser as well as the Race Director. The series organiser reserves the right to retain the recordings. The purpose of the recordings is to analyse on-track incidents, demonstrate examples of bad driving standards as a means of prevention and help the Race Director and the event organiser to make decisions.

Drivers are forbidden from removing the recordings from the car of their own accord after each session (also applies in the case of retirement/after an accident) or to analyse,

duplicate or manipulate the data before it is removed. Systems may only be used by drivers following the approval of the BMW. Infringements of these regulations may result in penalties.

**The following systems must be installed in the car:**

- Driver ID - X2 Driver ID Club Set
- GPSauge
- Transponder - MYLaps TR2 Transponder
- RaceLink -BASE X2 Racelink Club Kit
- Harness - BMW M2R Harness Kit

Electronics must be installed as per the Technical Regulations (**INSTALLATION DRAWINGS TBD**)

Systems to monitor tyre pressures using sensors and antennas are not permitted. Pressure-regulating valves are not permitted.

## **ENDURANCE EVENT REFUELING**

### **General**

- 3.1.1. During Endurance Race Events in Pit Lane, fuel must be transferred from the autonomous supply tank to the Car using the equipment and methods defined in this Article.
  - a. Approved equipment as defined herein must be:
    - i. Unmodified.
    - ii. Installed and operational.
  - b. Approved method:
    - i. Gravity.
- 3.1.2. Fuel transferred to the autonomous supply tank must be delivered by means of a hose fitted with a self-sealing connector (e.g. dry break, cam-lock) connected to the autonomous supply tank.

### **3.2. Autonomous Tank**

- 3.2.1. Construction of the Autonomous Supply Tank must:
  - a. Comply with FIA Appendix J Article 257A Drawing n° 252-7 with the exception of the top plate shape and dimensions.
  - b. Not have sensors other than as required by IMSA.
- 3.2.2. Refueling tank height is measured from the top surface of the vessel, not including vent, cover plate or fasteners, at a distance of 1.25 meters from the outermost face of the pit wall
- 3.2.3. The required Autonomous Tank heights are as follows:
  - a. Teams utilizing an Autonomous Tank trolley (non scissor/X-brace style) are permitted to utilize a maximum height of 1.83 m (6 ft) with a tolerance of +0 cm.

- b. Scissor style (X-brace) stand height has a maximum height of 1.83 m (6 ft) with a tolerance of +0 cm.

### 3.3. Peripheral Connections

3.3.1. Tanks must be equipped with the IMSA-specified peripheral connections between the tank outlet and the refueling hose.

- a. Parts must be purchased from RPXpress and used unmodified:

Part Number	Part	Description
BSR-FR FN40	Outlet Flange	Bottom Tank 12-bolt housing
ATL-TF 147	12-Bolt Gasket	2 Needed (Outlet and Vent Flanges)
BSR.FR.R.35GOLD	35.0mm Restrictor	Upper Restrictor (for positive seal to Elbow)
BSR-FR 1981	Bottom 80 deg. Elbow	Female Camlock x 2" Male
BSR.P.5K56.SS	Restrictor Housing	Deadman Outlet, 2" Male to 1 1/2" Camlock
BSR.P.5K.RPX.SS	Hose Coupler	1.5" OD barb to Deadman outlet
BSR-FR-R290	29.0 Refueling Restrictor	Deadman Outlet Restrictor (for positive seal to hose)
BSR.FR.DD	Discriminator	Rollover safety valve
BSR.FR.FN39	Vent mounting flange	Top surface mounting flange
1 Deadman Valve:		
BSR-FR-R003	Deadman Valve (new design)	Stainless Deadman Valve
BSR-FR-R002	Deadman Valve (old design)	Brass Deadman Valve

- b. Alternate discriminator valve(s) and associated mounting flange(s) may be permitted by IMSA Officials.
- c. Refueling System Assembly Illustration:

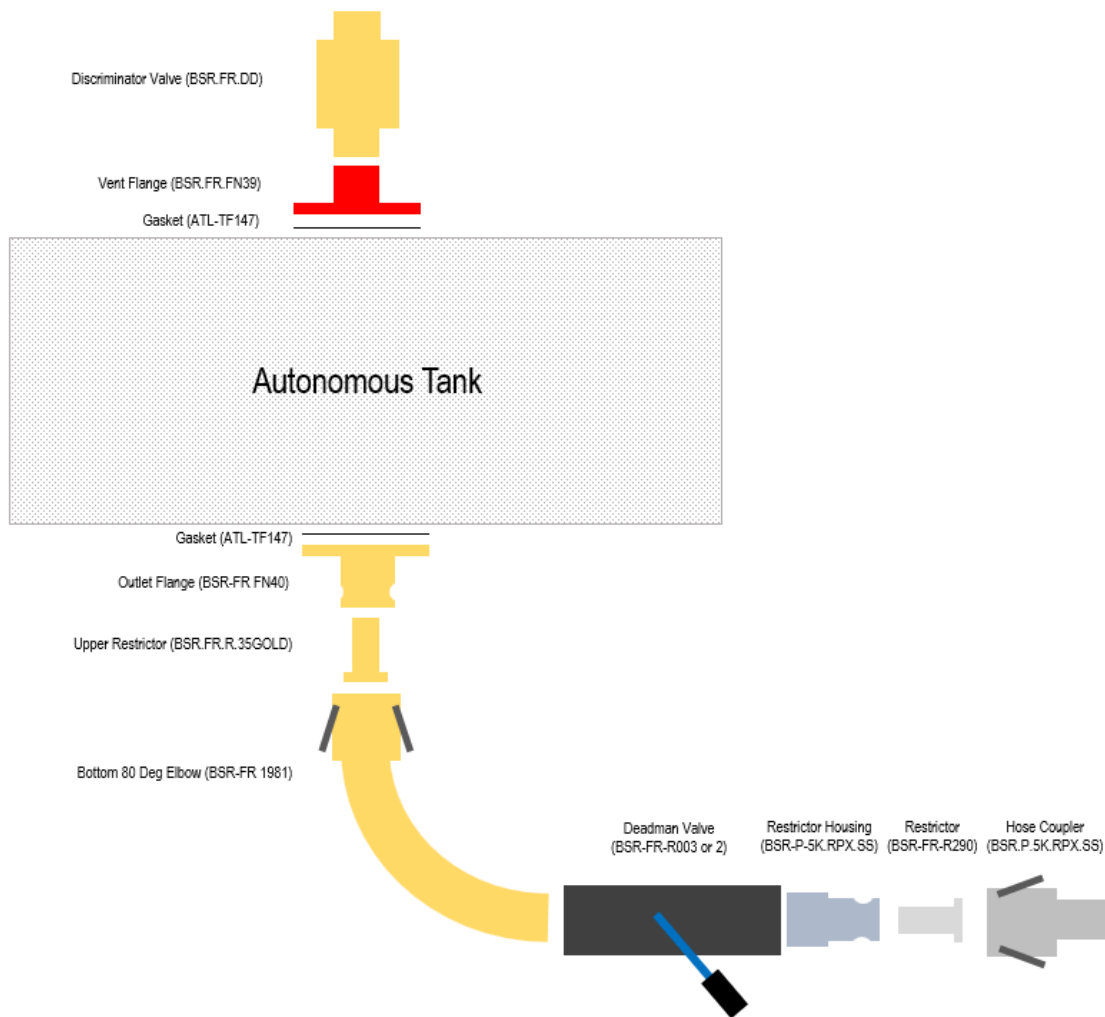

- 3.3.2. Deadman valve and bottom 80 deg. elbow assembly must be securely braced to remain attached to the tank in the event of an incident.
  - a. Mechanisms preventing normal operation of the deadman valve are prohibited.
- 3.3.3. During refueling the air vent outlet must be connected using an appropriate coupling to the tank.
- 3.3.4. A sight glass is permitted to be installed to the outside of the supply tank, and must be equipped with isolating valves mounted as close as possible to the tank.
- 3.3.5. Vent tube may be shaped to avoid interference with overhead obstruction(s), the minimum functional vent height of 1 m must be respected per FIA Appendix J Article 257A Drawing n° 252-7.
- 3.3.6. A foam-based spark arrester must be installed in the vent head and remain visible from the pit lane surface.

### 3.4. Refueling Hoses

- 3.4.1. Refueling/vent hoses must have one end equipped with a self-sealing connector to fit the autonomous supply tank outlet.
- 3.4.2. Refueling/vent hoses are permitted to be protected for the sole purpose of resisting abrasion damage.
  - a. Cover must be easily removable by means of full-length Velcro or zipper.
  - b. Cover must be non-reflective
- 3.4.3. Hose maximum inside diameter
  - a. Dual-Port systems must be less than 1.5 inches for all hoses.
  - b. Single-Port (coaxial) systems must be less than 1.5 inches for Refueling Hose and less than 75.0mm for the vent hose.
- 3.4.4. Refueling hose minimum length must be greater than 4.0 m
  - a. Minimum length is measured from the most distant plane of the dry break/fuel probe to the most distant plane of the Hose Coupler.

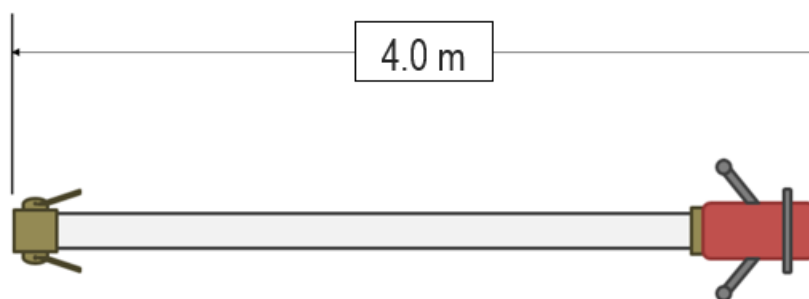

### 3.5. Tank Support Stand

- 3.5.1. The tank must be attached to one of the following:
  - a. To a trolley meeting the following requirements:
    - i. All tower components must be assembled without any degree of freedom in relation to the trolley.
    - ii. Have a surface area greater than two (2) square meters.
    - iii. Utilize four (4) self-braking casters.
    - iv. Be ballasted with weight exceeding that of the tank when filled with fuel.
  - b. Scissor style (X-brace) stand
  - c. Other apparatus as approved by IMSA
- 3.5.2. Tank Support Stand is permitted to have load sensors for the sole purpose of weighing fuel in the Autonomous Tank.
- 3.5.3. Tank Support Stand must have a minimum of two (2) support feet directly on the paved surface without the use of shims.
  - a. One shim is permitted to be added to support feet.
  - b. Shim(s) must have a greater area in contact with the ground than the foot.
  - c. Multiple shims are permitted to be used under a foot, provided:
    - i. The shims are securely fastened together by means of bolts and/or screws.
    - ii. The foot is securely attached to the shim by means of bolts/screws.



- iii. The assembled height of the shim must be safe to the satisfaction of IMSA Officials.
- 3.5.4. Tank Support Stand feet must be wider than the Autonomous Tank diameter.
- 3.5.5. Tank Support Stand setup and leveling assembly(s) must be secure to the satisfaction of IMSA Officials.

### 3.6. Boom

Not Applicable

### 3.7. Refueling Restrictor

- 3.7.1. During refueling, all fuel entering the Car must pass through the refueling restrictor.
- 3.7.2. Refueling restrictors must be purchased from RPXpress and used without modification (Phone: +1-828-428-0820 Email: [lmcelwain@rpxpress.com](mailto:lmcelwain@rpxpress.com)).
  - a. The mandatory Refueling Restrictor size is **29.0 mm**.
    - i. Restrictor must be used as-delivered from RPX.

### 3.8. Autonomous Tank Sensor System

Not Applicable

## Scrutineering Fuel Collection

- 2.1.1. Fuel Collection Vessel must:
  - a. Be non-opaque.
  - b. Be free of any carriage or trolley system.
  - c. Have a flat bottom.
  - d. Rest without assistance on the IMSA scale for weight measurement before and after defueling the Car.
- 2.1.2. Fuel Pump Out Hoses
  - a. Entrant must utilize 2 separate hoses for defueling activities:
    - i. Fuel drain
    - ii. Vent return
  - b. Both hoses must connect the Car to the collection vessel.
  - c. Must utilize dry-break connections to the Car and fixed (sealed) connections to the fuel collection vessel.
- 2.1.3. Fuel drain hose must have a clear section of no less than 250 mm near the collection vessel.