

# 2026 TECHNICAL REGULATIONS

Revision Date: 06/16/2026



Series:

**IMSA WEATHERTECH SPORTSCAR CHAMPIONSHIP**

Classes:



**GRAND TOURING DAYTONA PRO**



**GRAND TOURING DAYTONA**



Sanctioned by:

**INTERNATIONAL  
MOTOR SPORTS  
ASSOCIATION**

One Daytona Blvd.  
Daytona Beach, FL 32114  
(O) +1 (386) 310-6500  
(F) +1 (386) 310-6695  
[www.imsa.com](http://www.imsa.com)



## Table of Contents

<b>Foreword:</b>	<b>3</b>		
<b>ARTICLE 1. DEFINITIONS SPECIFIC TO THE TECHNICAL REGULATIONS</b>	<b>6</b>		
<b>ARTICLE 2. TECHNICAL PHILOSOPHY</b>	<b>6</b>		
2.1. Technical Eligibility	6		
2.2. Changes	7		
2.3. Conflict Resolution	7		
2.4. Final Authority	7		
2.5. Conditions for Use of a Specific Homologation	7		
<b>ARTICLE 3. TECHNICAL TESTING AND VERIFICATION</b>	<b>7</b>		
3.1. Reference Components	7		
3.2. Technical Testing	8		
<b>ARTICLE 4. BALANCE OF PERFORMANCE</b>	<b>8</b>		
4.1. Balance of Performance	8		
<b>ARTICLE 5. SAFETY</b>	<b>8</b>		
5.1. Driver Safety Harness System	8		
5.2. Seat	9		
5.3. Driver Containment Nets	9		
5.4. Protective Padding	9		
5.5. Master Electrical Switches	9		
5.6. Fire Suppression System	10		
<b>ARTICLE 6. DEFINITION OF CLASS</b>	<b>10</b>		
6.1. Grand Touring Daytona (GTD, GTD-PRO)	10		
<b>ARTICLE 7. VEHICLE SYSTEMS</b>	<b>10</b>		
7.1. General	10		
7.2. Modifications to the Specification	10		
7.3. Servicing, Repair, and Replacement	11		
7.4. Dimensions	11		
7.5. Chassis	11		
7.6. Driver Interface	11		
7.7. Bodywork	12		
7.8. Aerodynamic Elements	13		
7.9. Engine System	13		
7.10. Boost Management	14		
7.11. Drive System	14		
7.12. Cooling System	14		
7.13. Fuel System	15		
7.14. Brake System	15		
7.15. Steering System	15		
7.16. Suspension System	16		
7.17. Wheels & Tires	16		
7.18. Electronics	16		
7.19. Powertrain Performance	17		
7.20. Energy Per Stint	18		
<b>ARTICLE 8. SERIES REQUIRED ELECTRONICS</b>	<b>18</b>		
8.1. General	18		
8.2. Series Scrutineering Data System	18		
8.3. Marshalling Display System	19		
8.4. Driver ID System	20		
8.5. X2 Transponder System	20		
8.6. Leader Light System	20		
8.7. Back-lit Panel	20		
8.8. Pro-Am Light (GTD)	20		
8.9. In-Car Camera	21		
8.10. Tire Pressure Monitoring System	21		
8.11. Accident Data Recorder	21		
8.12. Driveshaft Torque Meters	22		
<b>ARTICLE 9. REFUELING SYSTEM</b>	<b>23</b>		
9.1. General	23		
9.2. Fuel Transfer	23		
9.3. Pit Tank	24		
9.4. Peripheral Connections	24		
9.5. Refueling Hose	25		
9.6. Autonomous Tank Support Stand	25		
9.7. Boom	25		
9.8. Refueling Restrictor	26		
9.9. Autonomous Tank Sensor System	26		
9.10. Scrutineering Fuel Collection	28		

## Foreword:

---

For all Members, the IMSA RULES of the International Motor Sports Association establish the foundation for the organization and conduct of all IMSA Sanctioned Events. The IMSA RULES take effect immediately upon publication.

The purpose of the RULES is to: (i) promote safety, the sport of automobile Competition and IMSA, (ii) enhance Competition, (iii) ensure the quality, fairness and integrity of the IMSA programs and operations and (iv) achieve prompt finality in the Competition results (“**Purpose**”).

### **ALL MEMBERS ARE REQUIRED TO REVIEW THESE IMSA RULES CAREFULLY.**

The **IMSA RULES** consist of following three (3) sections and the Event Supplementary Regulations (**SR**):

- The Technical Regulations, which outline the rules and regulations for the specific cars and equipment. The Technical Regulations may be modified or changed at any time by the publication of a Technical Bulletin, amending the Technical Regulations.
- The IMSA Sporting Regulations (**ISR**), which concern Competitor and Event procedures, as well as guidelines for the safe and uniform operation of the sport. The ISR may be modified or changed at any time by the publication of a Competition Bulletin, amending the ISR.
- The Series Supplementary Regulations (**SSR**) that provides Series-specific information about each IMSA Series. The SSR is integrated into the ISR and are designated with “(SSR)” next to the Paragraph title. The SSR may be modified or changed at any time by the publication of a Competition Bulletin, amending the SSR.

Any portion of the RULES may be modified through Bulletins (Competition Bulletins and Technical Bulletins, respectively) and takes force when published. Once published, the Bulletin shall take precedence over the applicable portion of the RULES. Additionally, the RULES may be modified for an Event by the Race Director through the mandatory briefing instructions.

### **HOW TO READ THE RULES**

IMSA Technical Regulations follow a common philosophy across all Classes. The IMSA Technical Regulation philosophy can be summed in the following concepts:

- Cars are constructed and regulated to a controlled standard, the vehicle Homologation.
- Modifications to the Car are not permitted unless specifically stated in the applicable class’s Technical Regulations.
- The Car, at all times, must adhere to:
  - The current Homologation Document(s) and valid extension documents (e.g., EVO).
  - The Manufacturer’s or Constructor’s Parts Manual (where applicable by the RULES).
  - Manufacturer submitted and IMSA approved declarations (where applicable).
  - The IMSA Technical Regulations for the Class
- Normal adjustment of the Car is permitted as defined by the applicable Car’s Homologation and Class’s Technical Regulations.
- Repair of the Car, parts, and components is permitted, provided it serves no additional purpose other than the repair itself. All such repairs must meet all Constructor / Manufacturer specifications and regulatory requirements.

(cont.)



Modifications by an Entrant to parts, systems, and/or components of the Car is not permitted for any reason. An Entrant wishing to perform any modification(s) must present modification(s) to the applicable Manufacturer or Constructor for formal approval from the applicable Homologating Authority for the Class. Entrants are not permitted to work directly with a Homologating Authority(s).

Entrants must have a current copy of the applicable Homologation for their Car Model at all times, as well as full access to the Manufacturer's / Constructor's Part Manual. Both of these documents together clearly identify the compliant specification of the Car and will be used as reference materials for both the Entrant and IMSA (where applicable by the RULES). A copy of the Homologation may be provided by the applicable Manufacturer / Constructor or purchased from the Homologating Authority.

IMSA's regulations work in conjunction with Homologation regulations from a Homologating Authority. This sometimes creates conflicts across the various regulation sets. Often the Homologating Authority has a combined set of Technical and Homologation regulations.

The hierarchy of these various regulations applies in descending order is as follows:

1. IMSA Class Technical Regulations and Bulletins
2. These IMSA Technical Regulations shall govern in any case where a conflict exists with the Homologation Regulations and Documentation.
3. Homologation Authority Technical Regulations and corresponding Homologation Form.

**Example 1: Incorrect process**

A Team has found that a suspension part of the Car is prone to failure when going over large bumps. The Team chooses to resolve the problem on their own and modifies the part with components made in their own shop, which are not in the Homologation or Parts Manual of the Car. IMSA Technical Staff find this modification during a post-Race inspection. IMSA finds that the car is not in the approved configuration and the Entrant is penalized.

**Example 2: Correct process**

A Team suspects a part on the Car may be prone to failure during longer races. The Team therefore informs their Manufacturer or Constructor representative of their concern. The Manufacturer or Constructor agrees that a modification or redesign is appropriate and submits a written proposal with supporting documentation to the Homologating Authority for review. Upon approval the Homologation documents are updated and distributed for equitable customer awareness and part implementation.

Homologation Authority for the Class:

Class	Homologating Authority
GTD and GTD PRO	FIA



**EXECUTIVE LEADERSHIP MASTHEAD**

<b>John Bishop* / Bill France, Sr.*</b>	<b>Founders – IMSA</b>
<b>Dr. Don Panoz*</b>	<b>Legacy Vice Chairman</b>
<b>Jim France</b>	<b>Chairman</b>
<b>Lesa Kennedy</b>	<b>Director</b>
<b>Ed Bennett</b>	<b>Chief Executive Officer</b>
<b>John Doonan</b>	<b>President</b>
<b>Amanda Oliver</b>	<b>Senior Vice President &amp; Legal Counsel</b>
<b>David Pettit</b>	<b>Senior Vice President, Marketing</b>
<b>Simon Hodgson</b>	<b>Senior Vice President, Competition</b>
<b>Brandon Huddleston</b>	<b>Vice President, Partnership Marketing and Business Development</b>

\*Deceased

## ARTICLE 1. DEFINITIONS SPECIFIC TO THE TECHNICAL REGULATIONS

---

- 1.1.1. **Car** means a singular representation of a Car Model, entered by an Entrant in an Event.
- 1.1.2. **Car Model** means a specific model of a vehicle constructed by an IMSA-recognized Manufacturer Partner, and intended for Competition.
- 1.1.3. **Class** means a category for Cars sharing a common set of Homologation Regulations and differentiated from others by type of Car Model.
- 1.1.4. **Competition** means a contest of competitive nature in which a Car takes part during an Event and results of which Competition are published.
- 1.1.5. **Constructor** means an entity that designs and builds race car chassis.
- 1.1.6. **Entrant** means an entity or person who has entered a Car that has been accepted for Competition and holds an IMSA Membership in the capacity of an Entrant or Entrant/Driver.
- 1.1.7. **Event** means an IMSA Sanctioned motorsport activity. It includes the designated Race as well as all periods for registration, inspections, practice Sessions, qualifying Sessions, racing, pre- and post-Race activities and inspections, and rain or postponed dates related thereto.
- 1.1.8. **Homologate** means to execute the Homologation Process.
- 1.1.9. **Homologated** means a Car Model approved through the Homologation Process.
- 1.1.10. **Homologation** means the concept of all things associated with Homologation Authority approval via the Homologation Process.
- 1.1.11. **Homologation Authority** means an entity with the authority to Homologate.
- 1.1.12. **Homologation Documentation** means all files, documents, information, and communication associated with the issuance of official approval of Homologation.
- 1.1.13. **Homologation Identifier** means the unique identifier (generally including a string of characters identifying the Category or Class of Homologation followed by a sequential number assigned to the Car Model) serving as a reference to the official approval of Homologation, assigned by the Homologation Authority.
- 1.1.14. **Homologation Process** means all procedures associated with petitioning a Homologation Authority for approval that a Car Model complies with the Homologation Regulations.
- 1.1.15. **Homologation Regulations** means a set of technical requirements and criteria used to design, construct, and document a Car Model intended for racing in a specific category or class of racing.
- 1.1.16. **Manufacturer** means a Manufacturer Partner constructing an approved Car Model.
- 1.1.17. **Manufacturer Partner** means a recognized IMSA Official Automotive Partner.
- 1.1.18. **Specification** means all technical characteristics of the Car Model defined by the Homologation and Technical Catalog.
- 1.1.19. **Specific Homologation** means the Homologation specific to a particular Car Model.
- 1.1.20. **Technical Catalog** means IMSA's collection of data and documents supporting a Car Model.
- 1.1.21. **Technically Eligible** means conforms to all technical requirements and criteria defined by these Technical Regulations.

## ARTICLE 2. TECHNICAL PHILOSOPHY

---

### 2.1. Technical Eligibility

- 2.1.1. Cars representing a Car Model must always respect the Specification.
- 2.1.2. To be eligible for participation in this Class, a Car Model must:
  - a. Be a Car Model constructed by an IMSA-recognized Manufacturer Partner.
  - b. Hold a valid Homologation, approved and issued by an IMSA-recognized Homologation Authority.
- 2.1.3. IMSA is the sole authority to define the Technical Eligibility of a Car Model and issue the Technical Credential.

## 2.2. Changes

- 2.2.1. Changes to the Specification are prohibited, unless explicitly authorized by IMSA.
- 2.2.2. Manufacturers alone are permitted to petition IMSA to change the Specification; requests by Entrants are not recognized.
- 2.2.3. IMSA retains sole authority to accept change(s) and/or update(s) to a Homologation (e.g. Variant Option, EVO, etc.) within fourteen (14) days of load in for an Event.

## 2.3. Conflict Resolution

- 2.3.1. These IMSA Technical Regulations shall govern in any case where a conflict exists with the Homologation Regulations and Documentation.

## 2.4. Final Authority

- 2.4.1. IMSA is the Final Authority with respect to these Technical Regulations.

## 2.5. Conditions for Use of a Specific Homologation

- 2.5.1. At all times during IMSA-sanctioned Events it is the Entrant's responsibility to ensure the configuration of the Car Model represents the Homologation components of the Specification, including:
  - a. As-Homologated Configuration
  - b. As-Delivered Configuration
  - c. IMSA Technical Eligibility Form
- 2.5.2. IMSA, in its sole discretion, may consider the Parts Manual and/or the As-Delivered condition for additional detail of parts or equipment not adequately detailed in the Homologation. Inclusion of parts or equipment in the Parts Manual and/or the As-Delivered condition does not explicitly permit their use.
- 2.5.3. The original, As-Homologated Configuration of the Car Model must not be modified unless permitted by these Technical Regulations.
- 2.5.4. The As-Delivered Configuration of a Car must respect the as-received configuration from the Car Model Manufacturer, unless permitted by these Technical Regulations.
- 2.5.5. The Parts Manual is the official parts catalogue for the Car Model as defined by the Car Model Manufacturer or Constructor:
  - a. Specific parts listed in the Parts Manual must be used on all representations of a Car Model unless permitted by these Technical Regulations.
- 2.5.6. To be eligible for use in any IMSA-sanctioned Event, modifications detailed in Homologation Extension Forms must:
  - a. Be approved by, or have initiated the process to obtain approval from, the Homologation Authority, and appended to the Car Model Homologation.
  - b. Be approved by IMSA.
  - c. Be available to all Entrants of the relevant Homologated Car for the next Event.
- 2.5.7. Homologated "endurance" extensions are permitted to be utilized in IMSA Events.
- 2.5.8. The IMSA Technical Eligibility Form is a part of the RULES and must be respected.

## ARTICLE 3. TECHNICAL TESTING AND VERIFICATION

---

### 3.1. Reference Components

- 3.1.1. IMSA may request Manufacturers submit reference components, tooling, and/or templates to the IMSA Technical Department
  - a. IMSA may retain these components without compensation.
- 3.1.2. Manufacturers are responsible for all costs related to submission of reference components.
- 3.1.3. Fees may apply.

### 3.2. Technical Testing

- 3.2.1. Testing conducted by IMSA may be performed including, but not limited to:
  - a. Wind Tunnel
  - b. Center of Gravity Testing
  - c. On-track Testing
- 3.2.2. Testing and associated costs are the responsibility of the applicable Manufacturer or Constructor.

## ARTICLE 4. BALANCE OF PERFORMANCE

---

### 4.1. Balance of Performance

- 4.1.1. IMSA may, at its discretion, utilize an adjustment method to maintain competitive equivalency between Cars within each Class, and between Classes.
  - a. Details of the Balance of Performance Process are described in Attachment 2 of the applicable Sporting Regulations.
- 4.1.2. Technical Bulletins are an extension of these Regulations and part of the Rules.
- 4.1.3. Providing false or intentionally misleading information is a breach of these Technical Regulations.

## ARTICLE 5. SAFETY

---

### 5.1. Driver Safety Harness System

- 5.1.1. Cars must be equipped with a minimum 6-point Driver safety harness with a valid label demonstrating compliance with one of the following standards:
  - a. FIA Standard 8853-2016: Safety Harnesses
    - i. [FIA Technical List #57](#): Harnesses Homologated according to the FIA Standard 8853-2016
- 5.1.2. Installation must be performed in accordance with instructions provided by the system supplier and/or manufacturer.
  - a. Belt components must be installed at each Homologated anchor point to prevent accidental release or opening.
  - b. Individual belt straps must be independent; any method or attempt to combine individual straps is prohibited.
  - c. Elastic retention straps are prohibited on shoulder belts.
- 5.1.3. Harnesses must be replaced at the request of IMSA, or whenever the following conditions occur:
  - a. Expiration:
    - i. FIA Homologated: Immediately following December 31<sup>st</sup> of the year printed on the label.
  - b. Damage:
    - i. Following a severe collision.
    - ii. Webbing is cut or frayed or weakened due to actions of chemicals or sunlight.
    - iii. Buckles are bent, deformed, rusted, or improperly functioning.
- 5.1.4. Entrants are responsible for ensuring the Driver safety harnesses and all associated components are properly labeled, installed, used, and maintained.
- 5.1.5. Belt components must be used as designed by the manufacturer. It is prohibited to mix belt components between manufacturers or certifications.

## 5.2. Seat

- 5.2.1. As homologated.
- 5.2.2. Seat Inserts
  - a. Seat insert materials must respect either:
    - i. [FIA Technical List 50](#)
    - ii. [SFI Specification 45.2](#)

## 5.3. Driver Containment Nets

- 5.3.1. Cars must be equipped with center, and Driver-side containment nets with a valid label demonstrating compliance with one of the following:
  - a. FIA Standard 8863-2013: Racing Nets
    - i. [FIA Technical List #48](#): Racing Nets Homologated according to the FIA Standard 8863-2013
- 5.3.2. Installation requirements:
  - a. Supplier and/or manufacturer installation instructions must be respected.
  - b. Horizontal webbing must be oriented towards the Driver.
  - c. When secured at anchor points, nets must be:
    - i. Oriented parallel to the Car centerline.
    - ii. Located with minimal gap to the Driver's helmet.
- 5.3.3. Containment nets must be replaced prior to the expiration date:
  - a. FIA Homologated: Immediately following December 31<sup>st</sup> of the year printed on the label.
- 5.3.4. Driver Containment Nets must remain free of modification(s) and/or signage.

## 5.4. Protective Padding

- 5.4.1. Cars must be equipped with non-flammable protective padding with a valid label demonstrating compliance with one of the following standards:
  - a. FIA Standard 8857-2001: FIA Roll Cage Padding Standard
    - i. [FIA Technical List #23](#): Roll Cage Padding Homologated by the FIA
  - b. SFI Specification 45.1: Roll Cage Padding
    - i. [Specification](#)
    - ii. [Manufacturers](#)
- 5.4.2. Installation requirements:
  - a. Padding must be located to protect the Driver (body and/or helmet) against direct contact with the safety cage in a collision.
  - b. Protective padding must be securely affixed to prevent rolling or displacement.

## 5.5. Master Electrical Switches

- 5.5.1. As Homologated.
- 5.5.2. Systems must remain functional during any on track activity or at the request of IMSA.
- 5.5.3. Interior and exterior master switches must be clearly identified by a self-reflective symbol of a red spark surrounded by a white-edged, blue triangle with a base greater than 30 mm.

## 5.6. Fire Suppression System

- 5.6.1. As Homologated
- 5.6.2. Identification
  - a. Exterior activation mechanism must be marked with a self-reflective symbol with a red edge surrounding a red "E" inside a white circle at least 100 mm in diameter.
  - b. The interior fire activation switch, located in cockpit, must be marked with an appropriately sized decal of a red "E" inside a white circle.
- 5.6.3. Inspection
  - a. IMSA may require removal of the fire bottle for Technical Inspection.
  - b. Entrant is responsible for demonstrating proper system function of the interior and exterior fire suppression activation mechanisms, using the "test" mode if present.

## ARTICLE 6. DEFINITION OF CLASS

---

### 6.1. Grand Touring Daytona (GTD, GTD-PRO)

- 6.1.1. Class Structure: Grand Touring Daytona Cars compete in the GTD and GTD-PRO Classes of the IMSA WeatherTech Sportscar Championship (IWSC).
- 6.1.2. Eligibility Requirements: To be eligible for participation in the Class, a Car Model must respect the Specification defined by the Homologation and Technical Eligibility requirements:
  - a. Homologation:

<b>Homologation Authority:</b>	Federation Internationale de l'Automobile (FIA)
<b>Homologation Specification:</b>	FIA Group GT3 (GT3)
<b>Homologation Regulations:</b>	<a href="#">FIA 2026 Technical Regulations for Grand Touring Cars (Group GT3)</a>
<b>Homologation Specification:</b>	FIA Group GT3 (GT3)

## ARTICLE 7. VEHICLE SYSTEMS

---

### 7.1. General

- 7.1.1. All Vehicle Systems and associated sub-systems are listed in this Article.
  - a. Where change to the Homologated Vehicle Systems is permitted, regulatory text is **bold and underlined**.
  - b. Where change to the Homologated Vehicle Systems is prohibited, regulatory text is light grey.
  - c. Advisory statements are in normal text.

### 7.2. Modifications to the Specification

- 7.2.1. Entrants are permitted to execute the following changes to parameters defined by the Homologation component of the Car Model Specification, provided these Technical Regulations, all current Technical Bulletins, and the Technical Credential are fully respected:
  - a. Adjust component settings defined as adjustable.
  - b. Replace components with parts defined as optional.
- 7.2.2. Manufacturers must make any declarations listed in these Technical Regulations in the IMSA Technical Eligibility Form.
- 7.2.3. Further authorization to modify the Specification and/or As-Delivered Condition is granted via the following formal communication methods:
  - a. Published IMSA Technical Bulletin
  - b. IMSA Technical Committee Bulletin
- 7.2.4. Informal and/or verbal communication is not considered valid authorization.

### 7.3. Servicing, Repair, and Replacement

- 7.3.1. All servicing or repair must be made in good faith to restore the Car and all components to their originally intended form and function as defined by the Specification.
- 7.3.2. Entrants are permitted to replace damaged or worn components provided these Technical Regulations are respected.

### 7.4. Dimensions

#### 7.4.1. General

- a. IMSA's calibrated measurement instruments are the official measurement instruments.
- b. Scrutineering measurement(s) are taken with the applicable dry-type tire set installed.
  - i. Tire compound per the applicable Event SR.
- c. Tire pressure shall be set at 30.0 psi ( $\pm 0.5$  psi) for scrutineering measurement(s).

#### 7.4.2. Reference Surfaces

- a. The flat floor reference surface of the Car is measured to the plane of the Technical Inspection surface plate.
- b. Manufacturer-provided, IMSA approved, chassis reference surface/jig.

#### 7.4.3. Mass

- a. The minimum mass for all Car Models is defined via Balance of Performance Tables and associated Technical Bulletins.
- b. Car mass is measured as-raced minus Driver and Fuel using the IMSA scales during Technical Inspection.

#### 7.4.4. Ballast

- a. **Entrants are permitted to add or remove ballast to Homologated BoP ballast location to achieve minimum mass:**
  - i. Ballast must be in plate or panel form.
  - ii. Addition or removal of ballast during the Race is prohibited.
- b. The Homologated ballast box is permitted to be removed when no ballast is present.

#### 7.4.5. Ground Clearance

- a. The minimum ground clearance for all Car Models is 50 mm.
- b. Ground clearance is measured across the complete underside of Car Model during Technical Inspection.

#### 7.4.6. Overall Dimensions

### 7.5. Chassis

#### 7.5.1. General

- a. **Entrants are permitted to execute minimum modifications for the installation of approved components.**
  - i. All modifications must be approved by IMSA.

### 7.6. Driver Interface

#### 7.6.1. General

- a. **Entrants are permitted to install a driver hydration system.**
  - i. Installations must be approved by IMSA.
  - ii. System must not serve any additional purpose.

#### 7.6.2. Steering Wheel

- a. **Entrants are permitted to add, and/or modify the shape of, steering wheel grips.**

#### 7.6.3. Pedal Box

- a. **Entrants are permitted to apply non-slip adhesives to the surface of driver pedals.**

#### 7.6.4. Shifting Mechanism

#### 7.6.5. Driver Adjustable Components

#### 7.6.6. Driver Cooling Systems

- a. **Entrants are permitted to install a maximum of two (2) driver cooling systems, i.e. cool suits.**
  - i. Installation of Driver Cooling System(s) is subject to IMSA approval
  - ii. Driver cooling systems must use non-flammable refrigerant (e.g. R134a, water).
  - iii. Driver cooling system must not impede driver egress.
- b. Installations must meet the following conditions:
  - i. The mounting location and installation for the primary system is unrestricted provided it serves no purpose other than retaining the cooling system in the event of a collision.
  - ii. Any secondary driver cooling system must be mounted on the top of or directly adjacent to the ballast box.
  - iii. All driver cooling system components must be securely mounted.
  - iv. The use of hook and loop fasteners (Velcro) is prohibited.

#### 7.7. Bodywork

##### 7.7.1. General

- a. **The following films are permitted to be added to the front windscreen:**
  - i. Tear-offs
  - ii. Anti-fog

##### 7.7.2. Bodywork Seams

- a. **Entrants are permitted to apply tape or vinyl around refueling receptacle seams and/or rear wing end fence adjustment holes.**
- b. Roof access panel seams and fasteners must remain free of obstruction

##### 7.7.3. Decals

- a. **Entrants are permitted to apply removable die cut sponsorship decals with the approval of IMSA.**
- b. Windows must remain free of decals and/or tint unless required by IMSA

##### 7.7.4. Headlights

- a. GTD Cars: when in use, headlights must emit yellow light.
- b. GTD-PRO Cars: when in use, headlights must emit white light.
- c. When in use, except in Pit Lane, main and auxiliary headlight system(s), (e.g. daytime running lights (DRL), endurance lighting, lights within the headlight assembly, etc.) must emit light respecting the headlight color of the Class.
- d. Headlight color must be satisfactory in the sole opinion of IMSA Officials.
- e. Exceptions for Homologated main and auxiliary headlight systems may be submitted solely by the Manufacturer for approval by IMSA.
  - i. Such Cars may be required to keep the main headlights on during all on-track activity.

##### 7.7.5. Bodywork Conformity

- a. Bodywork conformity to the Homologated shape will be performed using a combination of measurements, jigs, and 3D scanning:
- b. Manufacturers must provide the following jigs to IMSA:
  - i. Reference plane angle (per Article 7.4.2)
  - ii. Rear wing angle
  - iii. Rear wing profile
  - iv. Diffuser profile
  - v. Splitter profile
- c. Reference scan 3D CAD file
  - i. Each OEM must supply the 3D reference CAD file of the wetted external surfaces for the Homologated Car Model (30 days prior to IMSA wind tunnel evaluation)
  - ii. The rear wing must be supplied in 1-degree steps from minimum to maximum
  - iii. Wheels (but not suspension) to be included

- iv. Solid surface patches for brake, engine and all other cooling apertures must be included
- v. No deviation from the Homologated geometry will be permitted without prior written approval from the FIA to IMSA
- d. Scan
  - i. Cars may be scanned at Events
  - ii. The scan and the reference scan file will be compared using a best fit approach (using the best fit technique integral to the metrology software)
  - iii. An OEM supplied reference plane jig may be used as a check of the congruity of this fit.
- e. Tolerances
  - i. Unless otherwise Homologated, the following tolerances shall be applied:
    - (i) General Bodywork: +/- 5 mm
    - (ii) Splitter and Diffuser Height: +/- 3 mm
    - (iii) Gurney Height: +/- 1 mm
- f. Deflection
  - i. IMSA reserves the right to introduce load/deflection tests on any part of the bodywork.

## 7.8. Aerodynamic Elements

### 7.8.1. General

### 7.8.2. Splitter

### 7.8.3. Dive Planes

### 7.8.4. Body Gurney

### 7.8.5. Wings

- a. Rear Wing Angle is measured using the Manufacturer's declared measurement process and/or chassis reference surface/jig.
- b. The minimum and maximum Rear Wing Angle for all Car Models is defined via BoP Tables and associated Technical Bulletins and is part of the Rules.

### 7.8.6. Floor

### 7.8.7. Friction Blocks

### 7.8.8. Diffuser

## 7.9. Engine System

### 7.9.1. General

- a. IMSA and/or Manufacturer seals must be respected

### 7.9.2. Engine

### 7.9.3. Oiling System

- a. Approved lubricants are permitted to be utilized.

### 7.9.4. Lambda

### 7.9.5. Engine RPM

- a. Engine must be fitted with scrutineering engine speed sensor which meets requirements of Bosch Scrutineering System Manual (BSSM) directly connected to scrutineering logger.

### 7.9.6. Intake

### 7.9.7. Exhaust

### 7.9.8. Turbo

### 7.9.9. Engine Control Unit (ECU)

## 7.10. Boost Management

N/A

## 7.11. Drive System

### 7.11.1. General

- a. Manufacturer seals must be respected

### 7.11.2. Fluids & Lubricants

- a. **Unrestricted.**

### 7.11.3. Clutch

### 7.11.4. Gearbox

### 7.11.5. Gears

- a. A gear set consists of the following ratios, and must always be used in its entirety:
  - i. 6 forward ratios
  - ii. 1 reverse ratio
  - iii. 1 final drive ratio
  - iv. 1 drop gear (if applicable)
- b. **In addition to the FIA Homologated gear set, Manufacturers of new homologations accepted by IMSA may declare one (1) additional gear set via the IMSA Technical Eligibility Form by 60 days prior to participation in the first Event:**
  - i. Daytona Gear Set
- c. Declared Daytona Gear Set must be used for Daytona Events.
- d. FIA Homologated set must be used for remaining Events.
- e. Gear Sets must be used in their entirety (i.e. mixing of ratios between sets is prohibited)

### 7.11.6. Gearbox Control Unit

### 7.11.7. Differential

### 7.11.8. Axles

- a. Driveshafts, torque sensors, anti-rotation devices (ARDs), and associated system(s) must be installed in accordance with the IMSA Technical Eligibility Form and Article 8.12
  - i. MagCanica UHA Torque Sensor must be installed per the supplier's requirements.

### 7.11.9. Uprights

## 7.12. Cooling System

### 7.12.1. General

### 7.12.2. Fluids

- a. **Entrants are permitted to utilize the following approved cooling fluids:**
  - i. Water
  - ii. Air
  - iii. Non-glycol based fluids

### 7.12.3. Inlet Blockers

- a. **Entrants are permitted to utilize the following approved methods for the sole purpose of blocking off portions of the cooling system inlet openings:**
  - i. Opaque adhesive tape
  - ii. Panels made from carbon fiber and/or aluminum with associated fastener hardware.

- 7.12.4. Water System
- 7.12.5. Oil Cooling System

### 7.13. Fuel System

- 7.13.1. General
- 7.13.2. Fuel Types
  - a. The approved fuel for the Class is IMSA E10, as supplied by VP Fuels.
    - i. IMSA may require a fuel sample for inspection via a gas chromatograph.
- 7.13.3. Fuel Cell
  - a. **Entrants must use blocks or balls to achieve maximum fuel cell capacity:**
- 7.13.4. Fuel Lines
- 7.13.5. Fuel Sample Port
  - a. **Entrants must equip the Car with an approved self-sealing connector for extraction of fuel samples:**
    - i. Approved Connector: Staubli P/N: CBI06.7251/IA/JKV.
    - ii. Must be located immediately before the injector nozzles.
    - iii. Installation must be approved by IMSA.
- 7.13.6. Refueling Receptacle

### 7.14. Brake System

- 7.14.1. General
- 7.14.2. Fluids & Lubricants
  - a. **Unrestricted.**
- 7.14.3. Bias Assembly
- 7.14.4. Master Cylinders
- 7.14.5. Brake Lines
  - a. **Where not Homologated, Entrants are permitted to install the Manufacturer submitted, IMSA approved, dry-break system for the applicable Car Model in accordance with the applicable IMSA Technical Eligibility Form.**
- 7.14.6. Calipers
- 7.14.7. Rotors
- 7.14.8. Pads
  - a. **Friction material is unrestricted.**
  - b. Backing Plates must be ferrous.
- 7.14.9. Ducting
- 7.14.10. Brake Duct Inlet Blockers
  - a. **Entrants are permitted to utilize the following approved methods for the sole purpose of blocking off portions of the brake duct inlet openings:**
    - i. Opaque adhesive tape.
    - ii. Panels made from carbon fiber and/or aluminum with associated fastener hardware.
  - b. Must be fixed.
- 7.14.11. Anti-Lock Braking System

### 7.15. Steering System

- 7.15.1. General



7.15.2. Fluids & Lubricants

- a. **Unrestricted.**

**7.16. Suspension System**

7.16.1. General

7.16.2. Geometry Elements

7.16.3. Springs

- a. **Entrants are permitted to change primary spring rates:**
  - i. The As-delivered number of springs per wheel must be respected.
- b. **Entrants are permitted to install thrust bearings between the spring and perch.**
  - i. Maximum of two (2) per spring.

7.16.4. Dampers

- a. **Entrants are permitted to change the damper internal build:**
  - i. Inerter technology is prohibited.

7.16.5. Bump Rubbers and Packers

- a. **Unrestricted.**

7.16.6. Anti-Roll Bar

7.16.7. Third Elements

**7.17. Wheels & Tires**

7.17.1. General

7.17.2. Wheels

7.17.3. Wheel Attachment

7.17.4. Tires

- a. The approved tire supplier for this Class is Michelin.
- b. Tires must be used in accordance with SSR Attachment 3.

**7.18. Electronics**

7.18.1. General

7.18.2. Data Logger

- a. **Entrants are permitted to install a data acquisition system where not included in the As-delivered Car.**
- b. IMSA reserves the right to download and/or view all logged data at any time.

7.18.3. Telemetry

- a. **Entrants are permitted to utilize one-way, car-to-pit, telemetry systems for data acquisition purposes.**
  - i. Video and voice transmission are not considered as “data acquisition purposes”.

7.18.4. Wiring Loom

7.18.5. Sensors

- a. As Homologated
- b. The following “Restricted” sensors are permitted per the applicable Car Model Homologation and (if fitted) must be transmitted to the IMSA Scrutineering System:
  - i. Pitot Pressure
  - ii. Laser Ride Heights

- c. Car Model(s) Homologated prior to January 1, 2022 must respect the manufacturer-submitted, IMSA Technical Eligibility Form.
- d. Sensor data must be accurate to the satisfaction of IMSA officials.

7.18.6. Radio

- a. **Entrants are permitted to install one (1) primary, and one (1) secondary, two-way voice communication radio with car-to-pit communication capability:**
  - i. Radio(s) must comply with Series Sporting Regulations.
  - ii. Secondary radio must not transmit or receive signals while primary radio is functional.

7.18.7. Rear View Camera

- a. **Where not homologated, Entrants are permitted to install a rear-view camera system.**

7.18.8. Auxiliary Power Sources

7.18.9. Rain Light

- a. One (1) rain light in compliance with FIA Standard 8874-2019 is mandatory
  - i. Must be installed at the back of the car and in working order throughout the Event.
- b. When in use, the Homologated Rain Light must be set to the following specifications:
  - i. 4 Hz
  - ii. 50% duty cycle

**7.19. Powertrain Performance**

7.19.1. General

- a. Maximum Power Limit
  - i. Each Manufacturer supplies a table of maximum power as a function of engine RPM which is documented in the IMSA Technical Eligibility Form.
    - (i) All values between the tabulated set points defined via the table are interpolated linearly.
  - ii. A percentage of maximum power as a function of engine RPM for applicable Car Models is defined via Balance of Performance Tables and associated Technical Bulletins.
- b. Power Control
  - i. The power will be monitored using torque sensors fitted on each driveshaft per the IMSA Technical Eligibility Form.
  - ii. For each sample the Left and Right torques will be summed.
    - (i) Each sample is filtered per the Regulatory Control Diagram.
  - iii. The Power=f(N) curve will be calculated with the following formula:

$$Power(t) = \left( M_{RightRearWheel}(t) * N_{RightRearWheel}(t) + M_{LeftRearWheel}(t) * N_{LeftRearWheel}(t) \right) * \frac{\pi}{30000}$$

- (ii) The reference engine speed "N" [rpm / maximum rpm] will also be taken at time "t". M refers to the filtered and offset torque [Nm].
  - iv. This corrected power curve will be compared to the data from the Technical Regulations using the logic detailed in the Regulatory Control Diagram. A maximum integral above this limit in kJ will be permitted with a down slope in kJ/s.
  - v. The main channel used for monitoring will be PowerIllegal: Integral of the instances of power above limit, decreased by a constant slope when Power is under the limit.
  - vi. Power levels must respect the stated maximum during on-track activity.
    - (i) Penalty(s) may apply for SSR Article 22.3.11.

c. Correction Factor

- i. The maximum powertrain performance is given for reference conditions.
- ii. If the ambient conditions naturally reduce performance, the maximum combined power curve will be corrected, at the beginning of each Event, to the ambient conditions using the following correction factor:

Reference Conditions: $P_{ref} = 1010$ mbar, $P_{vap\_ref} = 12$ mbar, $T_{ref} = 20^{\circ}\text{C}$ $P_{atmo}$ (Atmospheric Pressure in mbar), $T_{atmo}$ (Atmospheric Temperature in $^{\circ}\text{C}$ ), $H_{atmo}$ (Atmospheric relative Humidity in %)	
$min$	$1; \frac{1}{\left( \frac{P_{ref} - P_{vap\_ref}}{\left( P_{atmo} - 6.1121 * \exp \left\{ \left( 18.678 - \frac{T_{atmo}}{234.5} \right) * \frac{T_{atmo}}{(257.14 + T_{atmo})} \right\} * \frac{H_{atmo}}{100} \right) \right)^{1.169}} * \frac{(T_{atmo} + 273)}{(T_{ref} + 273)} \right)}$

**7.20. Energy Per Stint**

7.20.1. General

- a. Stint lengths are balanced through a Virtual Tank which contains the available permitted energy.
- b. The Virtual Tank starts the Race full and is depleted by the power used over time as measured by the driveshaft torque sensors.
- c. Before the Virtual Tank is empty, the Car must stop in the pits to replenish the energy for the next stint.
- d. Energy is replenished at a fixed rate when the IMSA Scrutineering System detects the connection of the fuel probe to the Car via the applicable proximity sensor.
- e. The Virtual Tank is not permitted to drop below 0%
  - i. The Car must replenish the extra energy used and serve a penalty per SSR Article 22.3.14.
- f. Calculations, details, and methodology are captured in the applicable Regulatory Control Diagram.

**ARTICLE 8. SERIES REQUIRED ELECTRONICS**

**8.1. General**

- 8.1.1. All Series required electronics must be installed per the applicable IMSA Technical Eligibility Form.
- 8.1.2. Entrant is responsible for the operation, maintenance, and care of Series required electronics.

**8.2. Series Scrutineering Data System**

- 8.2.1. Cars must be equipped with the IMSA Scrutineering Data System at all Events.
  - a. The manual for the Scrutineering Data System for the Class is the Bosch Scrutineering Systems Manual (BSSM).
    - i. Entrant must use the most current version of the BSSM as posted to the [IMSA Competitor site](#).
    - ii. Entrant must use all sensors, parts, and equipment as specified in the BSSM.
  - b. Scrutineering system components must be purchased from, or supplied by, the approved sources listed in the BSSM.
  - c. The scrutineering system and all its components are standalone and intended for IMSA use.
  - d. Entrants must install, utilize, and maintain other sensor(s) as required by IMSA.
- 8.2.2. All components of the Scrutineering System, and other sensors as required by IMSA, must remain powered and functional 5 minutes prior to and throughout all Sessions, unless the Car ceases participation.
- 8.2.3. Entrants must complete [IMSA Scrutineering Sensor Declaration Form](#) no later than 5 days before load-in day of every Event.
- 8.2.4. Scrutineering system components and sensors must be installed per the IMSA approved Car Model's IMSA Technical Eligibility Form.
  - a. VMPS unit must be:
    - i. Aligned within 1 degree of centerline of Car.

- ii. Aligned within 0.5 degrees of horizontal.
  - b. Fuel Flow Sensor must have a valid calibration for the entire duration of all IMSA Sanctioned Events.
    - i. Fuel Flow Sensor calibration expires at the end of each Season.
    - ii. Entrants are responsible for ensuring the sensor is recalibrated at the beginning of each Season.
  - c. Scrutineering Telemetry System
    - i. Transmitter and antenna must be installed per the IMSA approved Car Model's IMSA Technical Eligibility Form.
  - d. All other antennas, or other components, on the Car must be installed at least 240 mm from the edge of the IMSA VMPS antenna.
  - e. Wiring loom must be:
    - i. Consistent with IMSA approved Car Model's IMSA Technical Eligibility Form.
    - ii. Provided by the Entrant.
    - iii. Independent of any other system.
    - iv. Removable.
    - v. Verified and serialized before Entrant participates in their first event of each season, per the Loom Certification outlined in the BSSM.
    - vi. Certifications are only valid for the season they are issued.
    - vii. Available for additional testing when requested by IMSA.
- 8.2.5. CAN channels must be configured per the applicable DBC file posted in the regulation section of [competitors.imsa.com](https://competitors.imsa.com).
  - a. Entrants must provide CAN channels from the ECU, chassis logger, or equivalent device per the CAN specification detailed in the applicable DBC.
  - b. CAN communication to the IMSA Scrutineering Logger must be transmitted directly from the device of origin, and not repeated through a 3<sup>rd</sup> party device, unless explicitly permitted by IMSA consistent with the IMSA approved Car Model's IMSA Technical Eligibility Form.
    - i. Example: Engine RPM must be transmitted directly from the ECU to the IMSA Scrutineering Logger, and not through the chassis logger.
  - c. Scrutineering sensors take precedence over CAN provided values from the ECU or chassis logger.
  - d. Scrutineering sensor outputs are provided to the Entrant over a Public CAN bus.
  - e. A [Public CAN Declaration Form](#) must be submitted and approved by IMSA for any public CAN bus usage beyond Series Scrutineering Sensors and messages.
- 8.2.6. Series Scrutineering Data System inspection and data collection requirements are:
  - a. Entrants must present all series mandated data collection media to the IMSA Technical Inspection trailer within thirty (30) minutes of the completion of each session.
    - i. For instances of less than 60 minutes from the end of a Session and the start of the next Session, Entrant must return both Session's data collection media within thirty (30) minutes of the completion of the second Session.
  - b. Series Scrutineering Data Logger must be installed and tested prior to Technical Inspection.
    - i. Entrant may be required to install USB Stick during inspection process at the direction of series officials.
  - c. Any repair to the looms must be approved by Bosch Motorsport and re-certification through Bosch Motorsport may be required.
- 8.2.7. Scrutineering system primary component units must have an IMSA Scrutineering Seal.
  - a. Each device ordered through Bosch Motorsport NA using the order form found in the Scrutineering System Manual will be delivered with the seal in place.

### 8.3. Marshalling Display System

- 8.3.1. Cars must be equipped with an approved Marshalling Display to indicate active flag status, purchased from the approved supplier.
  - a. XAP NTX Marshalling Display

<a href="#">XAP NTX Marshalling Display</a>	Creative Motorsports Solutions
<a href="#">MSE Antenna Kit</a>	
<a href="#">MSE Safety Light Receiver</a>	

- 8.3.2. The Marshalling Display system must be installed and functioning during on-track activity.
- a. The supplied antenna must be mounted per the applicable IMSA approved Car Model's IMSA Technical Eligibility Form.

#### 8.4. Driver ID System

- 8.4.1. Cars must be equipped with a Driver ID system to identify the active Driver piloting the Car.
- 8.4.2. Driver ID plugs must be installed and connected per the BSSM.
- 8.4.3. Transponder and plugs must operate to the satisfaction of the Timing and Scoring Officials.

#### 8.5. X2 Transponder System

- 8.5.1. Cars must be equipped with the X2 Transponder System Kit (Qty 1) to transmit scrutineering data from the car.
  - a. X2 Transponder Kit contains the following component(s):
    - i. Transponder.
    - ii. Isolation Mounts.
  - b. Entrant must supply the following additional item(s):
    - i. X2 Transponder Mounting Bracket (must be purchased via [Creative Motorsport Solutions.](#))
    - ii. M4 Socket Head Cap Screw and Washer.
- 8.5.2. X2 transponder must be purchased via [Creative Motorsport Solutions.](#)
- 8.5.3. Entrant is permitted to install and utilize a backup X2 Transponder System if included in the IMSA Technical Eligibility Form for the applicable Car Model.
  - a. Backup X2 Transponder System must adhere to requirements of the primary system and the BSSM.
- 8.5.4. Transponder and optional backup system(s) must be installed per the IMSA approved Car Model's IMSA Technical Eligibility Form and function during Events to the satisfaction of IMSA.
  - a. Must be installed with appropriate thermal protection where the temperature cannot exceed 50 °C

#### 8.6. Leader Light System

- 8.6.1. Cars must be equipped with approved LED leader light system as follows:
  - a. XAP Leader Light System from Creative Motorsports Solutions ( <https://www.gomuchfaster.com/products/imsa-xap-led-position-panel> )
- 8.6.2. Leader light system must be installed and functioning during the Event.
  - a. Leader lights must be installed and connected to the Scrutineering System Loom per the Car Model's IMSA Technical Eligibility Form.
- 8.6.3. CAN communication of leader light system must be uninhibited by system(s) of the Car.

#### 8.7. Back-lit Panel

- 8.7.1. Cars must be equipped with white light-emitting side number panels for Races taking place partly by night.
  - a. Colored background must be cut out in the number shapes so they are illuminated during the night.
  - b. White light-emitting side number panels are supplied by Entrant.

#### 8.8. Pro-Am Light (GTD)

- 8.8.1. GTD Cars must be equipped with a [Pro-Am light](#) per the IMSA approved Car Model's IMSA Technical Eligibility Form.
  - a. Light must be powered on for GTD Cars during any on-track activity.
    - i. Light provides class identification.



## 8.9. In-Car Camera

- 8.9.1. Cars may be required to carry In-Car-Cameras (ICC).
  - a. Entrants must cooperate with the official broadcaster in the installation of the camera, including the provision of power for the equipment.
    - i. 2.5 A for camera power using with DTM06-2S-E007 connector:
      - o Pin 1: +12 VDC
      - o Pin 2: GND
    - ii. May require a battery pack.
  - b. Cars must mount an actual ICC, or the ICC replacement dummy unit, on their roof, and must:
    - i. Be mounted opposite side of centerline of the Car from the Driver
    - ii. 12.5" rearward of the trailing edge of the windshield
    - iii. 4.5" off the centerline of the roof
    - iv. Or as approved by IMSA
  - c. ICC replacement replica unit must be purchased from RPXpress (Phone: +1-828-428-0820  
Email: [lmcelwain@rpxpress.com](mailto:lmcelwain@rpxpress.com))
  - d. Cars equipped with ICC must display the Car number in the ICC's home position field of vision.
  - e. ICC must not be removed or disabled by the Entrant for any Session.
  - f. If installed, ICC replacement dummy minimum weight is one (1) pound.
  - g. Camera system wiring including power and antennas must be isolated and separated from scrutineering system components, wiring, and/or power.

## 8.10. Tire Pressure Monitoring System

- 8.10.1. All Cars must utilize an appropriate motorsports specification Tire Pressure Monitoring System (TPMS) which operates on the FIA TPMS Standard Communications Protocol
  - a. TPMS System and components must be installed as defined in the Car Model's IMSA Technical Eligibility Form.
  - b. System must be listed on FIA TECHNICAL LIST N° 106.
    - i. FIA Seal on all systems must remain intact.
  - c. Devices not connected directly to scrutineering CAN bus, must respect specified message forwarding requirements detailed in Bosch Scrutineering Systems Manual (BSSM).
  - d. All wheels must be equipped with TPMS sensors.
  - e. TPMS must transmit pressure data when the Car is in motion.
  - f. Encryption must be valid and data accurate to the satisfaction of IMSA officials.

## 8.11. Accident Data Recorder

- 8.11.1. Entrants must utilize the MoTeC ADR2 Accident Data Recorder
  - a. Must have IMSA certification sticker.
  - b. Must be installed per the Car Model's IMSA Technical Eligibility Form and consistent with FIA GT3 Homologation.
  - c. ADR2 must be installed and functional for all on-track activity.
  - d. Data collected by the ADR2 is property of IMSA.
  - e. ADR2 must be surrendered upon request by IMSA.
  - f. ADR2 must be purchased as follows:

<a href="#">Accident Data Recorder</a>	MoTeC USA
--	-----------



## 8.12. Driveshaft Torque Meters

### 8.12.1. General

- a. Driveshaft Torque Meters must be consistent with the applicable Car Model's IMSA Technical Eligibility Form.

### 8.12.2. Offset Test Procedure

- a. Extension loom(s) must not compromise CAN Bus lengths for a 1 Mbit bus.
  - i. Maximum overall length 40 m.
  - ii. Maximum branch length 300 mm.
- b. Must be performed by the following procedure unless otherwise communicated via Technical Bulletin:

Step	Action
1	Ensure hub is free of any additional mass or load, including but not limited to: Wheels, wheel nuts, set up stands, warm up weights.
2	Ensure Scrutineering USB data stick is inserted in the designated scrutineering logger port.
3	Disconnect the torque sensor bodies from their respective anti-rotation devices.
4	Verify that the extension looms are securely connected to both torque sensors simultaneously.
5	Initiate the offset test on the sensor under evaluation by activating the "Offset Start Trigger" bit for the corresponding axle being tested. The trigger must be sent by an approved external device.
6	Manually rotate the torque sensor body three full turns forward at a very slow and uniform rate, ensuring no mechanical resistance is generated.
7	Manually rotate the torque sensor body three full turns backward at the same slow and uniform rate, without inducing resistance, returning to the original starting position.
8	Terminate the offset test by triggering the " <b>Offset Stop Request</b> " bit for the corresponding axle using an external device only.
9	Observe the "Offset Calc Complete" status bit. A valid test requires the bit to transition from low to high and back to low. If this condition is not met, repeat steps 5 through 9.
10	Repeat steps 5 through 9 for each torque sensor body. Two valid offset tests must be completed per sensor.
11	Upon completion of both sensors tests, disconnect the extension looms, reconnect the main loom, and reattach the anti-rotation devices.
12	Export and submit the offset test data stored on the Scrutineering USB data stick as one file to the required team location.

### 8.12.3. Offset Test Schedule

- a. Must be performed and corresponding data submitted for axles to be used on the Car within these windows unless otherwise communicated via Technical Bulletin:

Test	Window Opens	Window Closes
1	Trailer Opening for the Event	Conclusion of Pre-Event Inspection
2	Conclusion of final Practice Session	1 hour prior to Qualifying
3	Conclusion of the Race or approved Retirement	30 minutes following the conclusion of the Race

- b. Additional offset tests may be required by IMSA.
- c. Offset tests must be submitted prior to on-track use following (but not limited to)
  - i. Over-torque
  - ii. Axle replacement
  - iii. Removal/reinstallation of axle
  - iv. Mechanical changes made to the driveline components
  - v. Removal/reinstallation of upright assembly
- d. The corresponding values measured during all offset testing must be recorded via Scrutineering USB data stick.

- e. IMSA must always have a time continuous record of the offset in the car during an Event.
- f. Offset tests must be conducted in the paddock and triggered by a device external to the car.
- g. Offset test must not be triggered over CAN unless conducting an IMSA required spin test per the spin test requirements.

#### 8.12.4. Change of Parts/Sensors

- a. Upon the change of axle(s) or torque sensor(s) in a Car prior to an Event, Entrants must provide history: quantity and magnitude of any Over Torque (OT) during non-IMSA sanctioned running, or axles intended for use in IMSA sanctioned track time by filling out the Sensor Scrutineering Declaration Form. Additional Data may be requested to the satisfaction of IMSA Officials.
- b. Upon the change of axle(s) or torque sensor(s) in a Car during an Event, Entrants must provide history: quantity and magnitude of any OT during non-IMSA sanctioned running, or axles intended for use in IMSA sanctioned track time prior to on-track use. Additional Data may be requested to the satisfaction of IMSA Officials.

#### 8.12.5. Usage and recalibration procedure

- a. Driveshaft(s) and torque sensor(s) may be required by IMSA to be inspected and/or recalibrated by the supplier when one of the following conditions are met
  - i. Sensors exceeding supplier defined maximum service life.
    - (i)  $t_{\text{CalibrationLife xx}}$  (where xx designates location of axle) > 3200
  - ii. If the offset value of a sensor shows a repeated deviation higher than 5 Nm between two subsequent spin tests.
  - iii. An OT instance of magnitude greater than or equal to 120% of calibrated torque limits of +/- 5500 Nm.
  - iv. After ten (10) OT instances of magnitude less than or equal to 120% of the calibrated torque limits of +/-5500 Nm.
  - v. If axle(s) or sensor(s) are damaged.
  - vi. If the offset absolute value exceeds 25 Nm.
- b. Entrant is responsible for tracking, maintaining, and ensuring driveshaft torque sensors respect the limits defined in 8.12.5.a.

#### 8.12.6. Calibration

- a. Calibration Range: +/- 5500 Nm.

#### 8.12.7. Service Life

- a. Entrants are responsible for tracking, maintaining, and ensuring driveshaft torque sensors will not exceed the maximum service life during an Event.
- b. Damage, fluid leakage, and/or excessive wear during an Event must be reported to IMSA Technical Officials immediately.

#### 8.12.8. Anti-Rotation Device (ARD)

- a. ARD installation must respect the torque sensor supplier requirements.

## ARTICLE 9. REFUELING SYSTEM

---

### 9.1. General

- 9.1.1. IMSA, at its sole discretion, may publish any variance to the Refueling System via applicable Technical Bulletin.

### 9.2. Fuel Transfer

- 9.2.1. Fuel must be transferred from the autonomous supply tank to the Car using the equipment and methods defined in this Article.
  - a. Approved equipment as defined herein must be:
    - i. Unmodified.
    - ii. Installed and operational.
  - b. Approved method:
    - i. Gravity.
- 9.2.2. Fuel transferred to the autonomous supply tank must be delivered by means of a hose fitted with a self-sealing connector (e.g. dry break, cam-lock) connected to the autonomous supply tank.

### 9.3. Pit Tank

9.3.1. Construction of the Autonomous Supply Tank must:

- Comply with FIA Appendix J Article 257A Drawing n° 252-7 with the exception of the top plate shape and dimensions.
- Not have sensors other than as approved by IMSA
- The maximum permitted refueling tank height is 2.2 meters as measured from the top surface of the vessel (not including vent, cover plate or fasteners) at a distance of 1.25 meters from the outermost face of the pit wall.

### 9.4. Peripheral Connections

9.4.1. Tanks must be equipped with the IMSA-specified peripheral connections between the tank outlet and the refueling hose.

- Parts below must be purchased from RPXpress (Phone: +1-828-428-0820 Email: [Imcelwain@rpxpress.com](mailto:Imcelwain@rpxpress.com)) and used unmodified:

Part Number	Part	Description
ATL-TF 147	12-Bolt Gasket	2 Needed (Outlet and Vent Flanges)
BSR.FR.1981.1	Bottom Elbow 67.12°	Female Camlock x Male 2" (Red)
BSR-FR R003	Deadman Valve	Stainless Deadman Valve
BSR.P.5K56.SS	Restrictor Housing	Deadman Outlet, 2" Male to 1 1/2" Camlock
BSR.P.5K.RPX.SS	Hose Coupler	Connects 1.5" I.D. hose to Restrictor Housing
BSR.FR.DD	Discriminator	Rollover safety valve
BSR.FR.FN39	Vent mounting flange	Top surface mounting flange

- Alternate discriminator valve(s) and associated mounting flange(s) may be permitted by IMSA Officials.
- Sensor must be oriented such that the face plate is directed toward the hot pit lane.
- FIA nut ring, as-supplied with original tank, must be used to secure the Sentronics Flow Sensor to the bottom of the supply tank using socket head cap screws.
- Refueling System Assembly Illustration:

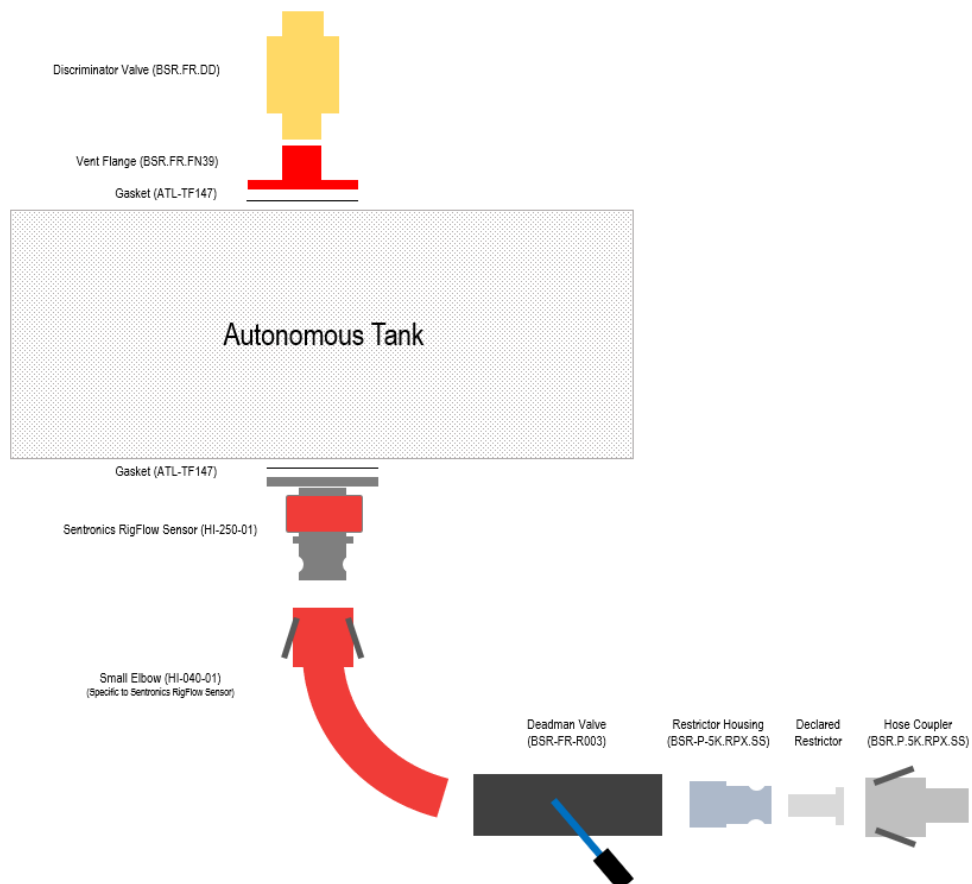

- 9.4.2. Deadman valve and bottom elbow assembly must be securely braced to remain attached to the tank in the event of an incident.
  - a. Mechanisms preventing normal operation of the deadman valve are prohibited.
- 9.4.3. During refueling the air vent outlet must be connected using an appropriate coupling to the tank.
  - a. In dual point refueling, the dedicated vent hose maximum inside diameter must be less than 1.5 inches.
- 9.4.4. A sight glass is permitted to be installed to the outside of the supply tank and must be equipped with isolating valves mounted as close as possible to the tank.
- 9.4.5. Vent tube may be shaped to avoid interference with overhead obstruction(s), the minimum functional vent height of 1 m must be respected per FIA Appendix J Article 257A Drawing n° 252-7.
- 9.4.6. A foam-based spark arrester must be installed in the vent head and remain visible from the pit lane surface.

### 9.5. Refueling Hose

- 9.5.1. Refueling/vent hoses must have one end equipped with a self-sealing connector to fit the autonomous supply tank outlet.
- 9.5.2. Refueling/vent hoses are permitted to be protected for the sole purpose of resisting abrasion damage.
  - a. Cover must be easily removable by means of full-length Velcro or zipper.
- 9.5.3. Hose maximum inside diameter:
  - a. Dual-port systems must be less than 1.5 inches for all hoses.
  - b. Single-port (coaxial) systems must be less than 1.5 inches for Refueling Hose and less than 75.0mm for Vent Hose.

### 9.6. Autonomous Tank Support Stand

- 9.6.1. The tank must be attached to one of the following:
  - a. To a trolley meeting the following requirements:
    - i. Have a surface area greater than two (2) square meters.
    - ii. Utilize four (4) self-braking casters.
    - iii. Be ballasted with weight exceeding that of the tank when filled with fuel.
  - b. Scissor style (X-brace) stand
- 9.6.2. Trolley is permitted to have load sensors for the sole purpose of weighing fuel in the Autonomous Tank.
- 9.6.3. Tank Support Stand must have a minimum of two (2) support feet directly on paved surface without the use of shims.
  - a. One shim is permitted to be added to support feet.
  - b. Shim(s) must have a greater area in contact with the ground than the foot.
  - c. Multiple shims are permitted to be used under a foot, provided:
    - i. The shims are securely fastened together by means of bolts and/or screws.
    - ii. The foot is securely attached to the shim by means of bolts/screws.
    - iii. The assembled height of the shim must be safe to the satisfaction of IMSA Officials.
- 9.6.4. Tank Support Stand feet must be wider than the Autonomous Tank diameter.
- 9.6.5. Tank Support Stand setup and leveling assembly(s) must be secure to the satisfaction of IMSA Officials.

### 9.7. Boom

- 9.7.1. Entrants are permitted to attach a member (boom) to the trolley.
  - a. Boom must be independent of the tank and the tower.
    - i. Boom member must be permitted a degree of freedom in relation to the trolley (rotation following a vertical axis).
  - b. Boom is permitted to support:
    - i. Hose for a Car utilizing an approved offset vent or fuel filler.
    - ii. Lighting for the illumination of the pit stop.
    - iii. Download cable.

- 9.7.2. Boom must be identified with the Car number fixed to its outboard end, that must be:
  - a. Visible from either direction
  - b. A minimum of seven (7) inches high with a 1.25-inch stroke
- 9.7.3. Boom must respect the following dimensions:
  - a. Must not exceed four (4) meters in length
  - b. Must permit free passage of a height of two (2) meters over its entire length including hoses and/or accessories.

## 9.8. Refueling Restrictor

- 9.8.1. During refueling, all fuel entering the Car must pass through the refueling restrictor.
- 9.8.2. Refueling Restrictor must meet the following criteria:
  - a. Material must be an aluminum alloy.
  - b. Must comply with the IMSA Fuel Restrictor Part Drawing at the end of these Technical Regulations.
  - c. Restrictor size varies from 22.0 mm to 35.0 mm by discrete increments 0.25 mm
  - d. Bore tolerance (+0.00 mm / -0.05 mm)
- 9.8.4. Refueling restrictors may be purchased from RPXpress (Phone: +1-828-428-0820 Email: [lmcelwain@rpxpress.com](mailto:lmcelwain@rpxpress.com)).

## 9.9. Autonomous Tank Sensor System

- 9.9.1. Autonomous fuel supply tanks must be equipped with Sentronics RigFlow autonomous tank fuel flow meter and wiring loom. Approved sensor and wiring harness as follows:
  - a. Flow sensor part number (HI-250-01).
  - b. Wiring harness part number ([CMS2021-1487](#)).
  - c. The fuel flow sensor kit and wiring loom must be purchased from an authorized Sentronics dealer
    - i. Sensors packages are serialized and assigned to a Car and Pit Tank.
  - d. Sensors packages must remain exclusive to the assigned Car and Pit Tank throughout the Event in which the sensor is declared.
- 9.9.2. Entrant must ensure the flow sensor system is functional.
  - a. Two hours before 1st Practice Entrant must connect the loom to a specific pit-lane network box designated by IMSA.
  - b. Loom must remain connected until the conclusion of the Event
  - c. Entrant must remove the loom at the conclusion of the Event.
  - d. Flow Sensor must be installed in the location and orientation as indicated in Article 9.3.
- 9.9.3. Wiring loom connects the sensor package to a dedicated port on the IMSA pit-lane network box.
  - a. Wiring loom must be IMSA certified and unmodified.
  - b. Wiring loom installation must remain visible and traceable.
  - c. Wiring loom part number ([CMS2021-1487](#)) must be connected directly to the flow sensor and directly to the pit-lane network per the drawing below.

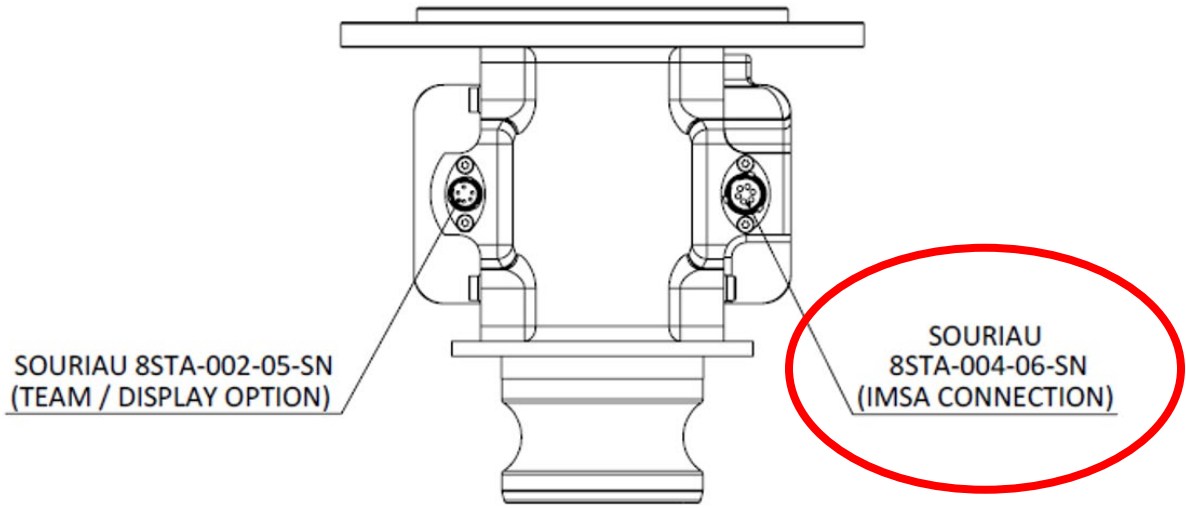

9.9.4. Entrant Data Port Access

- a. Entrant is permitted to access data provided by the RigFlow meter by utilizing approved part(s) from approved vendors as listed below:

Part	Vendor Link
Greaves Rig Flow APMS V3 System (including approved harness)	<a href="#">Greaves</a>
RigFlow Harness (approved harness only)	<a href="#">Creative Motorsports Solutions</a>

- b. Approved harness is permitted to be directly connected to the appropriate port of the RigFlow meter per the drawing below:

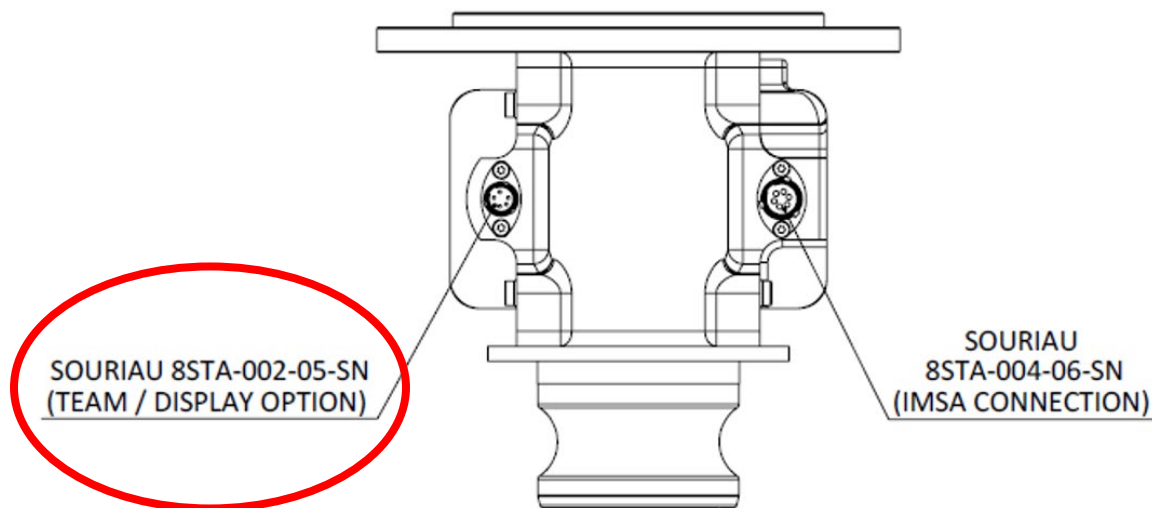

**9.10. Scrutineering Fuel Collection**

9.10.1. Fuel Collection Vessel must:

- a. Be non-opaque.
- b. Be free of any carriage or trolley system.
- c. Have a flat bottom.
- d. Rest without assistance on the IMSA scale for weight measurement before and after defueling the Car.

9.10.2. Fuel Pump Out Hoses

- a. Entrant must utilize 2 separate hoses for defueling activities:
  - i. Fuel drain
  - ii. Vent return
- b. Both hoses must connect the Car to the collection vessel.
- c. Fuel drain hose must utilize a dry-break connection to the Car and fixed (sealed) connection to the fuel collection vessel.
- d. Fuel vent return hose is permitted to utilize a temporary or dry-break connection to the Car and must use a fixed (sealed) connection to the fuel collection vessel.
- e. Fuel drain hose must have a clear section of no less than 250 mm near the collection vessel.

